

POLE AND EQUIPMENT SCHEDULE

POLE NO.	POLE STANDARD			VEHICLE SIGNAL				PEDESTRIAN SIGNAL			HPS LUMINAIRE (WATTS)	SPECIAL REQUIREMENTS		
	TYPE	SIG. MA (FEET)	OCS SL	No.	TYPE	MOUNTING	VISORS	LOUVERS	No.	TYPE			MOUNTING	
Ⓐ	SIGNAL, SL & OCS COMBO POLE	35	2700 272	21 24 27	3S12" 3S12" 3S12"GUA	SV-1-T MAS MAS	T T T			28	1S-COUNT	SP-1	-	SIGNAL MA MOUNT AT 22.5' HIGH APS ⬡
Ⓑ	1-A (10')	-		42 85	3S12" 3S12"	TV-2-T	T T			89	1S-COUNT	SP-1	-	APS ⬡
Ⓒ	NEW SL	-		41	3S12"	SV-1-T	T			48	1S-COUNT	SP-1	-	APS ⬡
Ⓓ	1-A (5')	-		-	-	-	-			-	-	-	-	APS ⬡
Ⓔ	SIGNAL, SL & OCS COMBO POLE	-	2690 268	25	3S12"	SV-1-T	T			29	1S-COUNT	SP-1	-	
Ⓕ	SPECIAL MAST ARM POLE (18-3-100)	30		61 64 67	3S12" 3S12" 3S12"GUA	SV-1-T MAS MAS	T T T			68	1S-COUNT	SP-1	-	SIGNAL MA MOUNT AT 20' HIGH APS ⬡ TSP ⬡
Ⓖ	1-A (10')	-		45 82	3S12" 3S12"	TV-2-T	T			49	1S-COUNT	SP-1	-	APS ⬡
Ⓗ	NEW SL	-		81	3S12"	SV-1-T	T			88	1S-COUNT	SP-1	-	APS ⬡
Ⓘ	1-A (10')	-		65	3S12"	TV-1-T	T			69	1S-COUNT	SP-1	-	APS ⬡

\*OTHER REQUIREMENTS ARE COVERED BY NOTES, LEGEND, SPECIAL PROVISIONS, AND STANDARD SPECIFICATIONS.  
FOR TYPE OF STANDARD, VEHICLE AND PEDESTRIAN SIGNAL MOUNTING, SEE CALTRANS STANDARD PLANS OR DETAIL DRAWINGS.

- ⬡ INSTALL APS WIRING AS SHOWN IN CONDUIT AND WIRING SCHEDULE. CITY FORCES TO INSTALL CITY FURNISHED APS UNIT.
- ⬡ INSTALL CITY FURNISHED TSP WIRING FROM TS OR COMBINED POLES WITH 3 FEET OF SLACK TO TS CABINET.
- ⬡ INSTALL CITY FURNISHED TRAFFIC CAMERA AND CONTRACTOR FURNISHED WIRING.
- ⬡ FOR STREETLIGHT WORK, SEE SL-SERIES PLANS.

I:\E-FILES\Projects\Van Ness BRT\Signal Design\CADD\CPTB401E1B5 - 100% Revised.dwg Kiewit Tue Nov 24, 2015 - 4:22 pm

NO.	DATE	DESCRIPTION	REVISED	CHECKED	APPROVED
REVISIONS					

DESIGNED: *R. King*  
 DRAWN: *R. King*  
 CHECKED: *Michael*  
 REVIEWED: *Charles*  
 RECOMMENDED: *Frederick*  
 APPROVED: *R. King*  
 DATE: 12/4/2015



CITY AND COUNTY OF SAN FRANCISCO  
**MUNICIPAL TRANSPORTATION AGENCY**

APPROVED: *[Signature]*  
 for the DIRECTOR OF TRANSPORTATION

MUNI BUS RAPID TRANSIT SYSTEM  
 VAN NESS CORRIDOR TRANSIT IMPROVEMENT PROJECT  
 GREENWICH STREET  
 CONDUCTOR POLE AND EQUIPMENT SCHEDULES

1289	REVISION
ET-128.1	
ET-204	

### CONDUIT AND WIRING SCHEDULE

CONDUIT RUN NUMBER	1	2	3	4	5	6	7	8	9	10	11	12	13	14	15	16	17	18	19	20	21	22	23	24	25	26	27
CONDUIT SIZE (INCH)	2	2	2	2	2	2	2	2	3	2	2	2	2	3	2	2	2	2	2	2	2	2	3	2	2	3	2
				SP	SP							SP	SP		SP				SP	SP				SP	SP		
VEHICLE SIGNAL Ø21	3		3							3				3													
VEHICLE SIGNAL Ø24	3		3							3				3													
VEHICLE SIGNAL Ø27	3		3							3				3													
PED SIGNAL Ø28P	2		2							2				2													
APS PPB FOR XING VAN NESS NS ON POLE A	2		2							2				2													
VEHICLE SIGNAL Ø42		3	3							3				3													
VEHICLE SIGNAL Ø85		3	3							3				3													
PED SIGNAL Ø89P		2	2							2				2													
APS PPB FOR XING GREENWICH ES ON POLE B		2	2							2				2													
VEHICLE SIGNAL Ø41						3			3		3			3													
PED SIGNAL Ø48P						2			2		2			2													
VEHICLE SIGNAL Ø25							3		3		3			3													
PED SIGNAL Ø29P							2		2		2			2													
APS PPB FOR XING GREENWICH ES ON POLE D								2	2		2			2													
APS PPB FOR XING VAN NESS SS ON POLE D								2	2		2			2													
VEHICLE SIGNAL Ø65																3		3						3			
PED SIGNAL Ø69P																2		2						2			
APS PPB FOR XING VAN NESS NS ON POLE I																2		2						2			
VEHICLE SIGNAL Ø81																		3	3					3			
PED SIGNAL Ø88P																		2	2					2			
APS PPB FOR XING GREENWICH WS ON POLE H																		2	2					2			
VEHICLE SIGNAL Ø45																							3		3		
VEHICLE SIGNAL Ø82																							3		3		
PED SIGNAL Ø49P																							2		2		
APS PPB FOR XING GREENWICH WS ON POLE G																							2		2		
VEHICLE SIGNAL Ø61																								3		3	
VEHICLE SIGNAL Ø64																								3		3	
VEHICLE SIGNAL Ø67																								3		3	
PED SIGNAL Ø68P																								2		2	
APS PPB FOR XING VAN NESS SS ON POLE F																								2		2	
#14 NEUTRAL	4	2				2	2									2	2					2	4				
#14 SPARE			3						3	3	3			6				3						3			
TOTAL #14 WIRES	17	12	26			7	7	4	17	26	17			40		9	9	17				12	17	40			
#10 WIRES NEUTRAL			1						1	1	1			2				1					2				
#6 WIRES (120 V SERVICE)																										2	
#8 WIRES (120 V SERVICE)																											2
#6 BSCW (SEE GENERAL NOTE 10)																											
TSP RECEIVER (10 CONDUCTOR CABLE)																							1	1			

I:\E-FILES\Sp\Projects\Van Ness BRT\Signal Design\CADD\CPB401ETBS - 100% Revised.dwg ikwong Mon Nov 23, 2015 - 6:02 pm

NO.	DATE	DESCRIPTION	REVISED	CHECKED	APPROVED

DESIGNED: *R. King*  
 DRAWN: *R. King*  
 CHECKED: *Cherrell*  
 REVIEWED: *Cherrell*  
 RECOMMENDED: *Cherrell*  
 APPROVED: *R. King*  
 DATE: *12/9/2015*

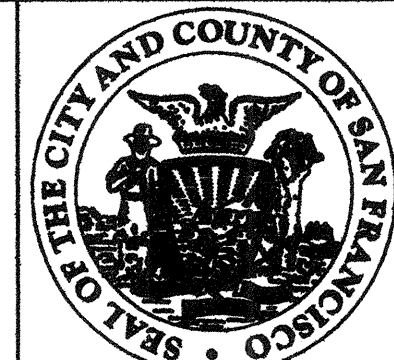

CITY AND COUNTY OF SAN FRANCISCO  
**MUNICIPAL TRANSPORTATION AGENCY**

APPROVED: \_\_\_\_\_  
 for the DIRECTOR OF TRANSPORTATION

MUNI BUS RAPID TRANSIT SYSTEM		1289
VAN NESS CORRIDOR TRANSIT IMPROVEMENT PROJECT		
GREENWICH STREET CONDUIT & WIRING SCHEDULES		ET-128.2 ET-204
		REVISION

I:\\_FILES\Signal\Projects\Van Ness\Signal Design\CADD\CF78401EBS - 100% Revised.dwg Kwong Thu Dec 03.2015 - 5:00 pm

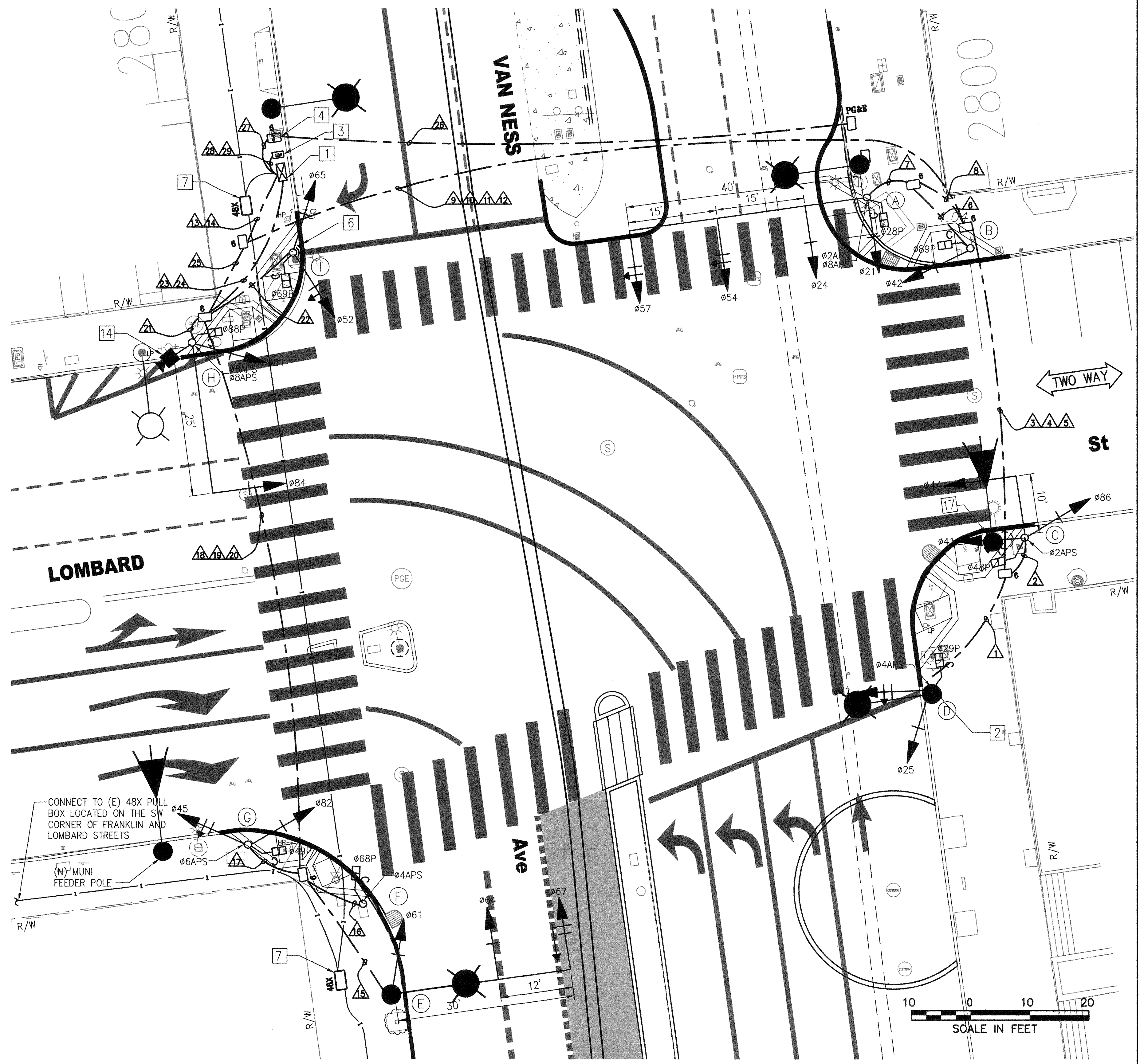
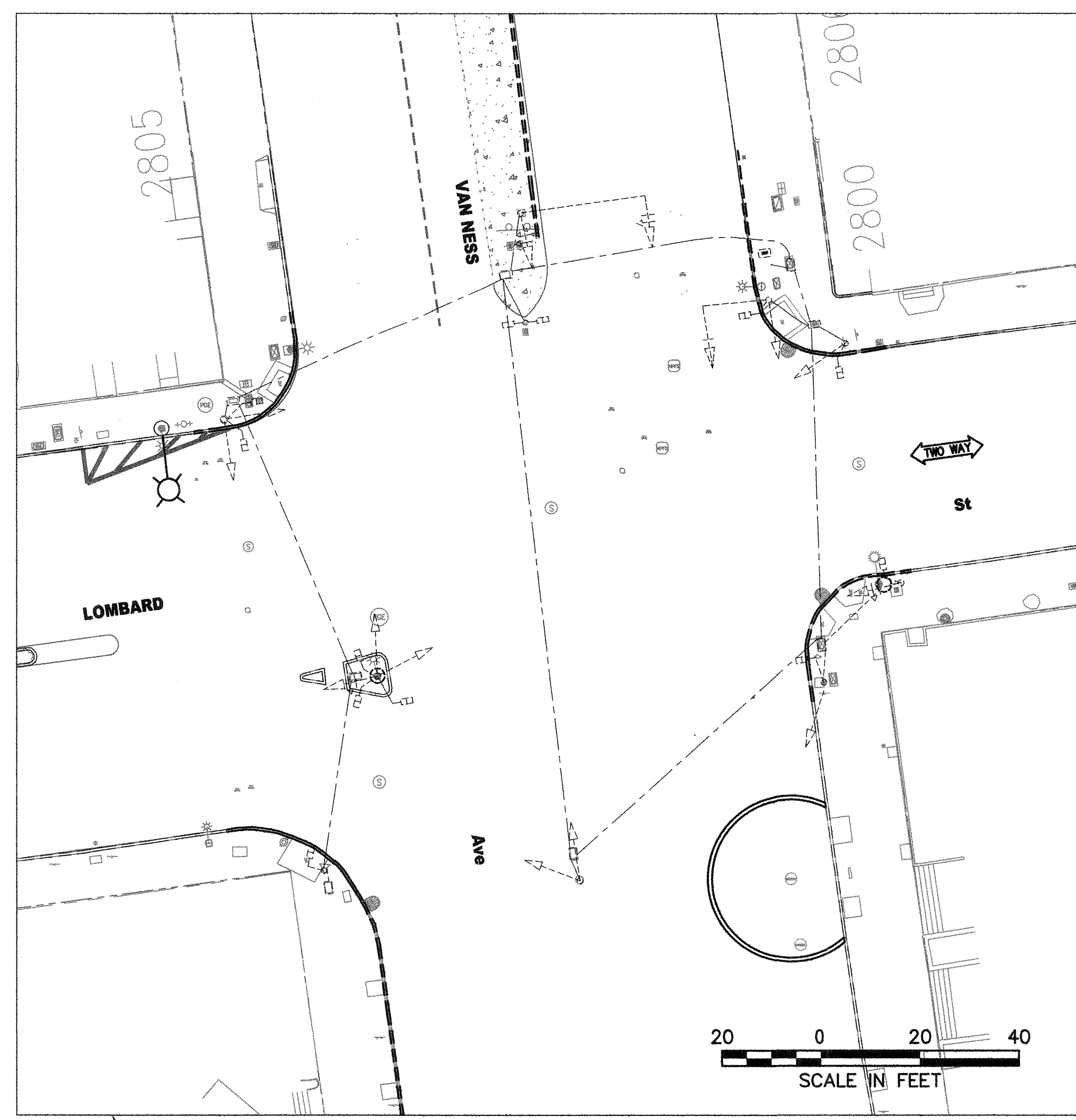

**EXISTING EQUIPMENT**

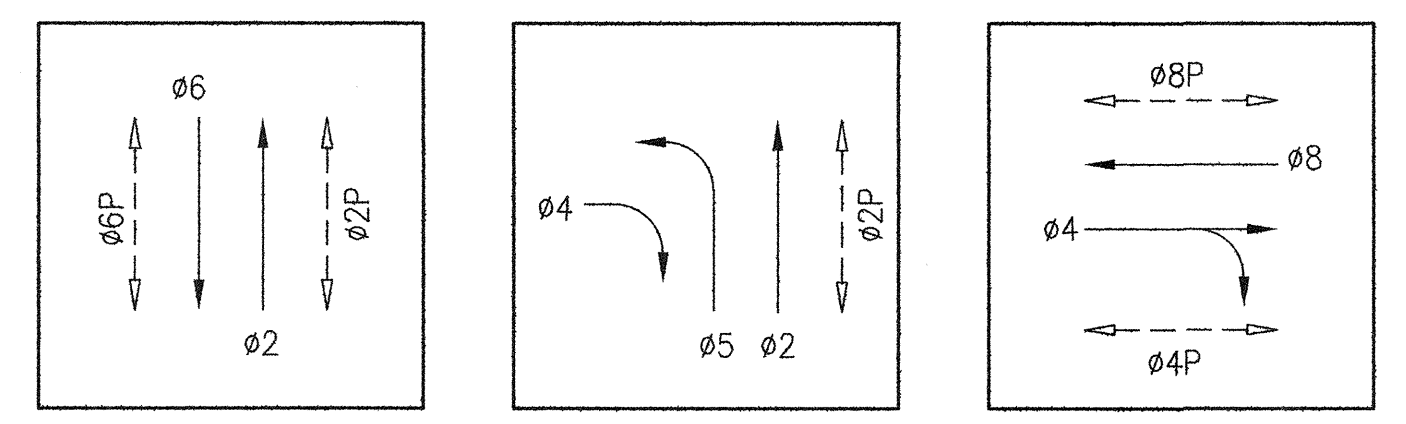

**PHASE DIAGRAM**

NO.	DATE	DESCRIPTION	REVISED	CHECKED	APPROVED
REVISIONS					

DESIGNED: *[Signature]*  
 DRAWN: *[Signature]*  
 CHECKED: *[Signature]*  
 REVIEWED: *[Signature]*  
 RECOMMENDED: *[Signature]*  
 APPROVED: *[Signature]*  
 DATE: 12/4/2015



CITY AND COUNTY OF SAN FRANCISCO  
**MUNICIPAL TRANSPORTATION AGENCY**

APPROVED: *[Signature]*  
 for the DIRECTOR OF TRANSPORTATION

MUNI BUS RAPID TRANSIT SYSTEM  
 VAN NESS CORRIDOR TRANSIT IMPROVEMENT PROJECT

LOMBARD STREET  
 TRAFFIC SIGNAL WORK

1289  
 ET-129.0  
 ET-204  
 REVISION

POLE AND EQUIPMENT SCHEDULE

POLE NO.	POLE STANDARD			VEHICLE SIGNAL				PEDESTRIAN SIGNAL			HPS LUMINAIRE (WATTS)	SPECIAL REQUIREMENTS	
	TYPE	SIG. MA (FEET)	DCS NO. SL NO.	No.	TYPE	MOUNTING	VISORS	LOUVERS	No.	TYPE			MOUNTING
(A)	SPECIAL MAST ARM POLE	40		21 24 54 57	3S12" 3S12" 3S12"LA 3S12"LA	SV-1-T MAS MAS MAS	T T T T		28	1S-COUNT	SP-1	-	SIGNAL MA MOUNT AT 22.5' HIGH APS ①
(B)	1-A(10')	-		42 85	3S12" 3S12"	TV-2-T	T T		89	1S-COUNT	SP-1	-	APS ①
(C)	17-2-100	10	133	44 41	3S12" 4S12"GRA	MAS SV-1-T	T T		48	1S-COUNT	SP-1	-	APS ① CONTRACTOR TO CONTACT USPS TO RELOCATE MAIL BOX
(D)	SIGNAL, SL & OCS COMBO POLE	-	279D 278	25 47	3S12" 4S12"GRA	SV-2-TA	T		29	1S-COUNT	SP-1	-	APS ①
(E)	SPECIAL MAST ARM POLE (19-3-100)	30		61 64 67	3S12" 3S12" 3S12"GUA	SV-1-T MAS MAS	T T T		-	-	-	-	SIGNAL MA MOUNT AT 20' HIGH
(F)	1-A (7')	-		-	-	-	-		68	1S-COUNT	TP-1	-	APS ①
(G)	1-A (10')	-		45 82	4S12"GRA 3S12"	TV-2-T-SFA	T		49	1S-COUNT	SP-1	-	APS ①
(H)	18-2-100	25		81 84	3S12" 3S12"	SV-1-T MAS	T		88	1S-COUNT	SP-1	-	APS ① TRAFFIC CAMERA ③
(I)	1-A (10')	-		52 65	3S12"LA 3S12"	TV-2-T-SFA	T T		69	1S-COUNT	SP-1	-	APS ① TSP ②

\*OTHER REQUIREMENTS ARE COVERED BY NOTES, LEGEND, SPECIAL PROVISIONS, AND STANDARD SPECIFICATIONS.  
FOR TYPE OF STANDARD, VEHICLE AND PEDESTRIAN SIGNAL MOUNTING, SEE CALTRANS STANDARD PLANS OR DETAIL DRAWINGS.

- ① INSTALL APS WIRING AS SHOWN IN CONDUIT AND WIRING SCHEDULE. CITY FORCES TO INSTALL CITY FURNISHED APS UNIT.
- ② INSTALL CITY FURNISHED TSP WIRING FROM TS OR COMBINED POLES WITH 3 FEET OF SLACK TO TS CABINET.
- ③ INSTALL CITY FURNISHED TRAFFIC CAMERA AND CONTRACTOR FURNISHED WIRING.
- ④ FOR STREETLIGHT WORK, SEE SL-SERIES PLANS.

T:\E\_FILES\Projects\Van Ness BRT\Signal Design\CADD\CPTB401EIBS.dwg Kikong Tue Jul 07 2015 - 3:56 pm

NO.	DATE	DESCRIPTION	REVISED	CHECKED	APPROVED

DESIGNED: *[Signature]*  
 DRAWN: *[Signature]*  
 CHECKED: *[Signature]*  
 REVIEWED: *[Signature]*  
 RECOMMENDED: *[Signature]*  
 APPROVED: *[Signature]*  
 DATE: 12/4/2015

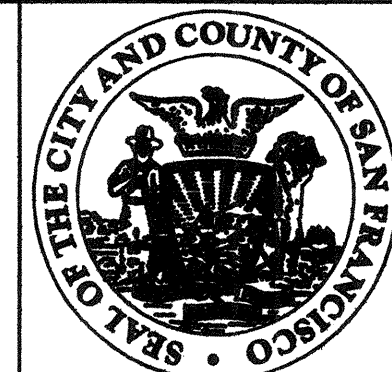

CITY AND COUNTY OF SAN FRANCISCO  
**MUNICIPAL TRANSPORTATION AGENCY**

APPROVED  
*[Signature]*  
 for the DIRECTOR OF TRANSPORTATION

MUNI BUS RAPID TRANSIT SYSTEM  
 VAN NESS CORRIDOR TRANSIT IMPROVEMENT PROJECT

1289

LOMBARD STREET  
 CONDUCTOR POLE AND EQUIPMENT SCHEDULES

ET-129.1  
 ET-204

REVISION

## CONDUIT AND WIRING SCHEDULE

CONDUIT RUN NUMBER	1	2	3	4	5	6	7	8	9	10	11	12	13	14	15	16	17	18	19	20	21	22	23	24	25	26	27	28	29
CONDUIT SIZE (INCH)	2	2	2	2	2	2	2	3	2	2	2	2	3	2	2	2	2	2	2	2	2	2	3	2	2	3	2	2	2
VEHICLE SIGNAL Ø25	3	3							3				3																
VEHICLE SIGNAL Ø47	4	4							4				4																
PED SIGNAL Ø29P	2	2							2				2																
APS PPB FOR XING VAN NESS SS ON POLE D	2	2							2				2																
VEHICLE SIGNAL Ø41		4	4						4				4																
VEHICLE SIGNAL Ø44		3	3						3				3																
VEHICLE SIGNAL Ø86		3	3						3				3																
PED SIGNAL Ø48P		2	2						2				2																
APS PPB FOR XING LOMBARD ES ON POLE C		2	2						2				2																
VEHICLE SIGNAL Ø42						3	3			3				3															
PED SIGNAL Ø89P						2	2			2				2															
VEHICLE SIGNAL Ø21							3	3		3				3															
VEHICLE SIGNAL Ø24							3	3		3				3															
VEHICLE SIGNAL Ø54							3	3		3				3															
VEHICLE SIGNAL Ø57							3	3		3				3															
PED SIGNAL Ø28P							2	2		2				2															
APS PPB FOR XING VAN NESS NS ON POLE A							2	2		2				2															
APS PPB FOR XING LOMBARD ES ON POLE A							2	2		2				2															
VEHICLE SIGNAL Ø61															3			3						3					
VEHICLE SIGNAL Ø64															3			3						3					
VEHICLE SIGNAL Ø67															3			3						3					
PED SIGNAL Ø68P																2		2						2					
APS PPB FOR XING VAN NESS SS ON POLE F																2		2						2					
VEHICLE SIGNAL Ø45																4		4						4					
VEHICLE SIGNAL Ø82																3		3						3					
PED SIGNAL Ø49P																2		2						2					
APS PPB FOR XING LOMBARD WS ON POLE G																2		2						2					
VEHICLE SIGNAL Ø81																							3		3				
VEHICLE SIGNAL Ø84																							3		3				
PED SIGNAL Ø88P																							2		2				
APS PPB FOR XING LOMBARD WS ON POLE H																							2		2				
APS PPB FOR XING VAN NESS NS ON POLE H																							2		2				
VEHICLE SIGNAL Ø52																								3		3			
VEHICLE SIGNAL Ø65																								3		3			
PED SIGNAL Ø69P																								2		2			
#14 NEUTRAL	2	4				2	5								3	2	2					3	2						
#14 SPARE			3					3	3	3			3	3				3					3						
TOTAL #14 WIRES	13	18	28			7	23	26	28	26			28	26	12	6	13	27				15	10	47					
#10 WIRES NEUTRAL			1					1	1	1			1	1				1					2						
#6 WIRES (120 V SERVICE)																									2				
#8 WIRES (120 V SERVICE)																											2		
#6 BSCW (SEE GENERAL NOTE 10)																													
#8 WIRES (BBS)																											2	2	
#6 GROUND (BBS)																											1	1	
TSP RECEIVER (10 CONDUCTOR CABLE)																							1	1					
CCTV CAMERA WIRES (CAT5e & 3#18)																							1	1					

T:\\_FILES\Projects\Van Ness BRT\Signal Design\CADD\CPTB401EIBS.dwg Monong Tue Jul 07, 2015 - 3:57 PM

NO.	DATE	DESCRIPTION	REVISED	CHECKED	APPROVED

DESIGNED: *[Signature]*  
 DRAWN: *[Signature]*  
 CHECKED: *[Signature]*  
 REVIEWED: *[Signature]*  
 RECOMMENDED: *[Signature]*  
 APPROVED: *[Signature]*  
 DATE: 12/4/2015



CITY AND COUNTY OF SAN FRANCISCO  
**MUNICIPAL TRANSPORTATION AGENCY**

APPROVED: *[Signature]*  
 for the DIRECTOR OF TRANSPORTATION

MUNI BUS RAPID TRANSIT SYSTEM  
 VAN NESS CORRIDOR TRANSIT IMPROVEMENT PROJECT

LOMBARD STREET  
 CONDUIT & WIRING SCHEDULES

1289

ET-129.2

ET-204





### CONDUIT AND WIRING SCHEDULE

CONDUIT RUN NUMBER	1	2	3	4	5	6	7	8	9	10	11	12	13	14	15	16	17	18	19	20	21	22	23	24	25	26	27	28	29	30	31	32	33	34	
CONDUIT SIZE (INCH)	2	2	2	2	2	2	2	3	2	2	2	2	2	2	2	2	2	3	2	2	2	2	2	2	2	2	2	2	2	3	2	2	3	2	
				SP	SP						SP	SP							SP			SP					SP	SP	EX			SP	SP		
VEHICLE SIGNAL 025	3		3						3					3				3																	
PED SIGNAL 029P	2		2						2					2				2																	
APS PPB FOR XING VAN NESS SS ON POLE D	2		2						2					2				2																	
VEHICLE SIGNAL 041		3	3						3					3				3																	
PED SIGNAL 048P		2	2						2					2				2																	
APS PPB FOR XING CHESTNUT ES ON POLE C		2	2						2					2				2																	
VEHICLE SIGNAL 042						3		3		3								3																	
VEHICLE SIGNAL 085						3		3		3								3																	
PED SIGNAL 089P						2		2		2								2																	
APS PPB FOR XING CHESTNUT ES ON POLE B						2		2		2								2																	
VEHICLE SIGNAL 021							3	3		3								3																	
VEHICLE SIGNAL 024							3	3		3								3																	
PED SIGNAL 028P							2	2		2								2																	
APS PPB FOR XING VAN NESS NS ON POLE A							2	2		2								2																	
VEHICLE SIGNAL 053													3		3				3																
TRANSIT SIGNAL 0153																					3	3													
VEHICLE SIGNAL 061																							2		2										
VEHICLE SIGNAL 064																							3		3										
TRANSIT SIGNAL 0151																							2		2										
PED SIGNAL 068P																							2		2										
APS PPB FOR XING VAN NESS SS ON POLE F																							2		2										
APS PPB FOR XING CHESTNUT WS ON POLE F																							2		2										
VEHICLE SIGNAL 045																								3		3									
VEHICLE SIGNAL 082																								3		3									
PED SIGNAL 049P																							2		2										
VEHICLE SIGNAL 081																												3							
PED SIGNAL 088P																												2							
APS PPB FOR XING CHESTNUT WS ON POLE H																												2							
APS PPB FOR XING VAN NESS NS ON POLE H																												2							
VEHICLE SIGNAL 052																													3						
VEHICLE SIGNAL 065																													3						
PED SIGNAL 069P																													2						
#14 NEUTRAL	2	2				2	3																4	2				2	2						
#14 SPARE			3					3	3	3				3	3			6				3													
TOTAL #14 WIRES	9	9	17			12	13	23	17	23			3	17	26			43			3	6		17	10	27		11	10	44					
#10 WIRES NEUTRAL			1					1	1	1			1	1	2			3			1	1				2							3		
#6 WIRES (120 V SERVICE)																																		2	
#8 WIRES (120 V SERVICE)																																			2
#6 BSCW (SEE GENERAL NOTE 10)																																			
TSP RECEIVER (10 CONDUCTOR CABLE)																													1		1				

T:\\_FILES\Sfgo\Projects\Van Ness BRT\Signal Design\CADD\CPTB401ETS.dwg Mewong Tue Jul 07, 2015 - 3:57 pm

NO.	DATE	DESCRIPTION	REVISED	CHECKED	APPROVED

DESIGNED <i>[Signature]</i>	DRAWN <i>[Signature]</i>
CHECKED <i>[Signature]</i>	REVIEWED <i>[Signature]</i>
RECOMMENDED <i>[Signature]</i>	APPROVED <i>[Signature]</i>
DATE 12/4/2015	

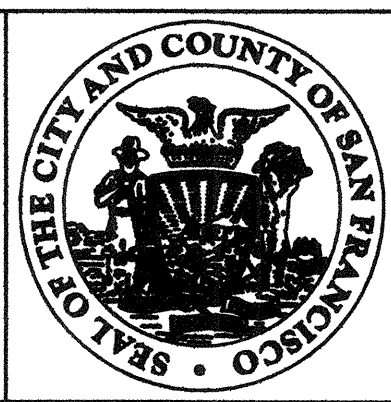
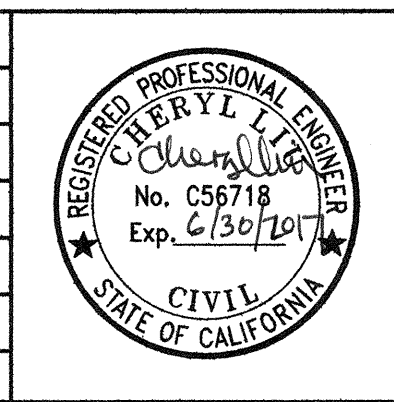

CITY AND COUNTY OF SAN FRANCISCO  
**MUNICIPAL TRANSPORTATION AGENCY**

APPROVED  
*[Signature]*  
for the DIRECTOR OF TRANSPORTATION

MUNI BUS RAPID TRANSIT SYSTEM  
VAN NESS CORRIDOR TRANSIT IMPROVEMENT PROJECT

CHESTNUT STREET  
CONDUIT & WIRING SCHEDULES

1289

ET-130.2

ET-204





POLE AND EQUIPMENT SCHEDULE

POLE NO.	POLE STANDARD			VEHICLE SIGNAL				PEDESTRIAN SIGNAL			HPS LUMINAIRE (WATTS)	SPECIAL REQUIREMENTS	
	TYPE	SIG. MA (FEET)	OCS <sup>no.</sup> / SL <sup>no.</sup>	No.	TYPE	MOUNTING	VISORS	LOUVERS	No.	TYPE			MOUNTING
(A)	SIGNAL & OCS COMBO POLE	35	3000 / 302	21 24 27	3S12" 3S12" 3S12" GUA	SV-1-T MAS MAS	T T T		28	1S-COUNT	SP-1	-	SIGNAL MA MOUNT AT 22.5' HIGH APS 1
(B)	1-A (10')	-		42 85	3S12" 3S12"	TV-2-T	T T		89	1S-COUNT	SP-1	-	APS 1
(C)	1-A (10')	-		41	3S12"	TV-1-T	T		48	1S-COUNT	SP-1	-	APS 1
(D)	SIGNAL, OCS SL & COMBO POLE	-	2960 / 298	25	3S12"	SV-1-T	T		29	1S-COUNT	SP-1	-	APS 1
(E)	SPECIAL MAST ARM POLE (23-3-100)	35		61 64 67	3S12" 3S12" 3S12" GUA	SV-1-T MAS MAS	T T T		68	1S-COUNT	SP-1	-	SIGNAL MA MOUNT AT 22.5' HIGH APS X 2 1
(F)	1-A (10')	-		45 82	3S12" 3S12"	TV-2-T	T		49	1S-COUNT	SP-1	-	
(G)	NEW SL	-	122	81	3S12"	SV-1-T	T		88	1S-COUNT	SP-1	-	APS X 2 1
(H)	1-A (10')	-		65	3S12"	TV-1-T	T		69	1S-COUNT	SP-1	-	TSP 2

\*OTHER REQUIREMENTS ARE COVERED BY NOTES, LEGEND, SPECIAL PROVISIONS, AND STANDARD SPECIFICATIONS.  
FOR TYPE OF STANDARD, VEHICLE AND PEDESTRIAN SIGNAL MOUNTING, SEE CALTRANS STANDARD PLANS OR DETAIL DRAWINGS.

- 1 INSTALL APS WIRING AS SHOWN IN CONDUIT AND WIRING SCHEDULE. CITY FORCES TO INSTALL CITY FURNISHED APS UNIT.
- 2 INSTALL CITY FURNISHED TSP WIRING FROM TS OR COMBINED POLES WITH 3 FEET OF SLACK TO TS CABINET.
- 3 INSTALL CITY FURNISHED TRAFFIC CAMERA AND CONTRACTOR FURNISHED WIRING.
- 4 FOR STREETLIGHT WORK, SEE SL-SERIES PLANS.

T:\E-FILES\Projects\Van Ness BRT\Signal Design\CADD\CPTB401EBS.dwg, Kiewit, Tue Jul 07, 2015 - 3:57 pm

NO.	DATE	DESCRIPTION	REVISED	CHECKED	APPROVED

DESIGNED	<i>[Signature]</i>
DRAWN	<i>[Signature]</i>
CHECKED	<i>[Signature]</i>
REVIEWED	<i>[Signature]</i>
RECOMMENDED	<i>[Signature]</i>
APPROVED	<i>[Signature]</i>
DATE	12/4/2015

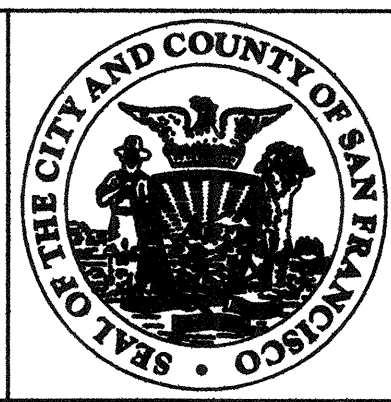
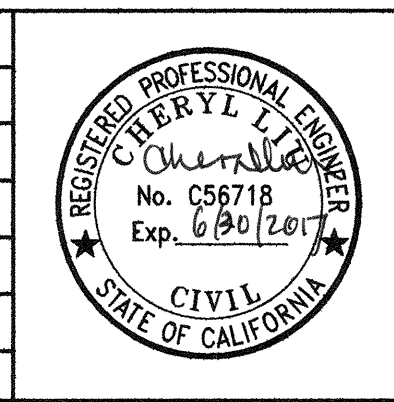

CITY AND COUNTY OF SAN FRANCISCO  
**MUNICIPAL TRANSPORTATION AGENCY**

APPROVED  
*[Signature]*  
for the DIRECTOR OF TRANSPORTATION

MUNI BUS RAPID TRANSIT SYSTEM  
VAN NESS CORRIDOR TRANSIT IMPROVEMENT PROJECT

FRANCISCO STREET  
CONDUCTOR POLE AND EQUIPMENT SCHEDULES

1289	REVISION
ET-131.1	
ET-204	

### CONDUIT AND WIRING SCHEDULE

CONDUIT RUN NUMBER	1	2	3	4	5	6	7	8	9	10	11	12	13	14	15	16	17	18	19	20	21	22	23	24	25	26
CONDUIT SIZE (INCH)	2	2	2	2	2	2	2	3	2	2	2	2	3	2	2	2	2	2	2	2	2	3	2	2	3	2
VEHICLE SIGNAL Ø25				SP	SP						SP	SP		SP				SP	SP				SP	SP		
PED SIGNAL Ø29P	3		3						3				3													
APS PPB FOR XING VAN NESS SS ON POLE D	2		2						2				2													
VEHICLE SIGNAL Ø41			3	3					3				3													
PED SIGNAL Ø48P			2	2					2				2													
APS PPB FOR XING FRANCISCO ES ON POLE C			2	2					2				2													
VEHICLE SIGNAL Ø42						3		3		3			3													
VEHICLE SIGNAL Ø85						3		3		3			3													
PED SIGNAL Ø89P						2		2		2			2													
APS PPB FOR XING FRANCISCO ES ON POLE B						2		2		2			2													
VEHICLE SIGNAL Ø21								3	3		3			3												
VEHICLE SIGNAL Ø24								3	3		3			3												
VEHICLE SIGNAL Ø27								3	3		3			3												
PED SIGNAL Ø28P								2	2		2			2												
APS PPB FOR XING VAN NESS NS ON POLE A								2	2		2			2												
VEHICLE SIGNAL Ø61																3		3					3			
VEHICLE SIGNAL Ø64																3		3					3			
VEHICLE SIGNAL Ø67																3		3					3			
PED SIGNAL Ø68P																2		2					2			
APS PPB FOR XING VAN NESS SS ON POLE E																2		2					2			
APS PPB FOR XING FRANCISCO WS ON POLE E																2		2					2			
VEHICLE SIGNAL Ø45																		3	3				3			
VEHICLE SIGNAL Ø82																		3	3				3			
PED SIGNAL Ø49P																		2	2				2			
VEHICLE SIGNAL Ø81																						3		3		
PED SIGNAL Ø88P																						2		2		
APS PPB FOR XING FRANCISCO WS ON POLE G																						2		2		
APS PPB FOR XING VAN NESS NS ON POLE G																						2		2		
VEHICLE SIGNAL Ø65																							3		3	
PED SIGNAL Ø69P																							2		2	
#14 NEUTRAL	2	2				2	4								4	2					2	2				
#14 SPARE			3					3	3	3			6				3						3			
TOTAL #14 WIRES	9	9	17			12	17	26	17	26			43	19	10	26					11	7	40			
#10 WIRES NEUTRAL			1					1	1	1			2			1							2			
#6 WIRES (120 V SERVICE)																									2	
#8 WIRES (120 V SERVICE)																										2
#6 BSCW (SEE GENERAL NOTE 10)																										
TSP RECEIVER (10 CONDUCTOR CABLE)																							1		1	

I:\V.L. FILES\SP\Projects\Van Ness BRT\Signal Design\CADD\PT6401ETBS.dwg ikwang Tue Jul 07, 2015 - 3:57 pm

NO.	DATE	DESCRIPTION	REVISED	CHECKED	APPROVED

DESIGNED: *[Signature]*  
 DRAWN: *[Signature]*  
 CHECKED: *[Signature]*  
 REVIEWED: *[Signature]*  
 RECOMMENDED: *[Signature]*  
 APPROVED: *[Signature]*  
 DATE: 12/9/2015

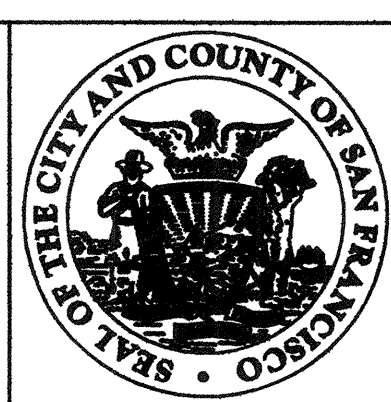
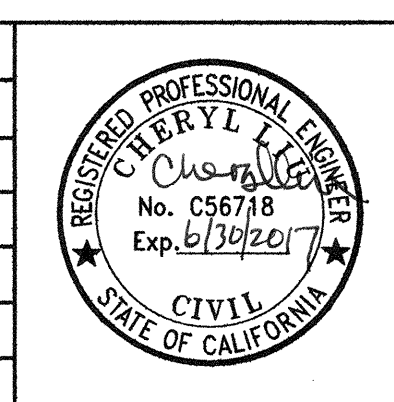

CITY AND COUNTY OF SAN FRANCISCO  
**MUNICIPAL TRANSPORTATION AGENCY**

APPROVED: *[Signature]*  
 for the DIRECTOR OF TRANSPORTATION

MUNI BUS RAPID TRANSIT SYSTEM  
 VAN NESS CORRIDOR TRANSIT IMPROVEMENT PROJECT

FRANCISCO STREET  
 CONDUIT & WIRING SCHEDULES

1289

ET-131.2  
 ET-204

REVISION



POLE AND EQUIPMENT SCHEDULE

POLE NO.	POLE STANDARD			VEHICLE SIGNAL					PEDESTRIAN SIGNAL			HPS LUMINAIRE (WATTS)	SPECIAL REQUIREMENTS	
	TYPE	SIG. MA (FEET)	OCS SL	No.	TYPE	MOUNTING	VISORS	LOUVERS	No.	TYPE	MOUNTING			
Ⓐ	SIGNAL, SL & OCS COMBO POLE	25	3102 312	21 24	3S12" 3S12"	SV-1-T MAS	T T			28	1S-COUNT	SP-1	-	SIGNAL MA MOUNT AT 22.5' HIGH APS ①
Ⓑ	1-A (10')	-		42 85	3S12" 3S12"	TV-2-T	T T			89	1S-COUNT	SP-1	-	APS ①
Ⓒ	16-2-100	20		41 44	3S12" 3S12"	SV-1-T MAS	T T			48	1S-COUNT	SP-1	-	APS ①
Ⓓ	SIGNAL, SL & OCS COMBO POLE	-	3062 308	25	3S12"	SV-1-T	T			29	1S-COUNT	SP-1	-	APS ① TRAFFIC CAMERA ②
Ⓔ	SPECIAL MAST ARM POLE (24-3-100)	35		61 64 67	3S12" 3S12" 3S12" GUA	SV-1-T MAS MAS	T T T			68	1S-COUNT	SP-1	-	SIGNAL MA MOUNT AT 22.5' HIGH APS ① TSP ②
Ⓕ	1-A (10')	-		45 82	3S12" 3S12"	TV-2-T-SFA	T			49	1S-COUNT	SP-1	-	APS ①
Ⓖ	16-2-100	20		81 84	3S12" 3S12"	SV-1-T MAS	T T			88	1S-COUNT	SP-1	-	APS ①
Ⓗ	SIGNAL, SL & OCS COMBO POLE	-	3101 311	52 65	3S12" LA 3S12"	SV-2-TA	T			69	1S-COUNT	SP-1	-	APS ①
Ⓘ	1-A (10')	-		53	3S12" LA	TV-1-T	T							
Ⓝ	PPBP POLE	-		-	-	-	-			-	-	-	-	APS ①

\*OTHER REQUIREMENTS ARE COVERED BY NOTES, LEGEND, SPECIAL PROVISIONS, AND STANDARD SPECIFICATIONS.  
FOR TYPE OF STANDARD, VEHICLE AND PEDESTRIAN SIGNAL MOUNTING, SEE CALTRANS STANDARD PLANS OR DETAIL DRAWINGS.

- ① INSTALL APS WIRING AS SHOWN IN CONDUIT AND WIRING SCHEDULE. CITY FORCES TO INSTALL CITY FURNISHED APS UNIT.
- ② INSTALL CITY FURNISHED TSP WIRING FROM TS OR COMBINED POLES WITH 3 FEET OF SLACK TO TS CABINET.
- ③ INSTALL CITY FURNISHED TRAFFIC CAMERA AND CONTRACTOR FURNISHED WIRING.
- ④ FOR STREETLIGHT WORK, SEE SL-SERIES PLANS.

T:\I.E. FILES\SP9\Projects\Van Ness BRT\Signal Design\CADD\CPT6401ETBS - 100% Revised.dwg Mkwong Mon Nov 23, 2015 - 12:32 pm

NO.	DATE	DESCRIPTION	REVISED	CHECKED	APPROVED

DESIGNED: *[Signature]*  
 DRAWN: *[Signature]*  
 CHECKED: *[Signature]*  
 REVIEWED: *[Signature]*  
 RECOMMENDED: *[Signature]*  
 APPROVED: *[Signature]*  
 DATE: 12/9/2015

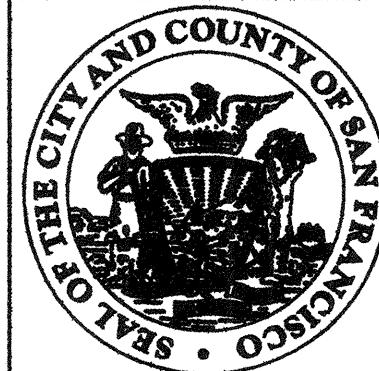

CITY AND COUNTY OF SAN FRANCISCO  
**MUNICIPAL TRANSPORTATION AGENCY**

APPROVED: *[Signature]*  
 for the DIRECTOR OF TRANSPORTATION

MUNI BUS RAPID TRANSIT SYSTEM		1289
VAN NESS CORRIDOR TRANSIT IMPROVEMENT PROJECT		
BAY STREET	CONDUCTOR POLE AND EQUIPMENT SCHEDULES	ET-132.1
		REVISION
		ET-204

### CONDUIT AND WIRING SCHEDULE

CONDUIT RUN NUMBER	1	2	3	4	5	6	7	8	9	10	11	12	13	14	15	16	17	18	19	20	21	22	23	24	25	26	27	28	29	30	31
CONDUIT SIZE (INCH)	2	2	2	2	2	2	2	2	2	2	2	2	3	2	2	2	2	1	2	2	2	2	2	2	3	2	2	3	2	2	2
				SP	SP						SP	SP		SP							SP	SP					SP	SP			
VEHICLE SIGNAL Ø21	3		3						3				3																		
VEHICLE SIGNAL Ø24	3		3						3				3																		
PED SIGNAL Ø28P	2		2						2				2																		
APS PPB FOR XING VAN NESS NS ON POLE A	2		2						2				2																		
VEHICLE SIGNAL Ø42			3	3					3				3																		
VEHICLE SIGNAL Ø85			3	3					3				3																		
PED SIGNAL Ø89P			2	2					2				2																		
APS PPB FOR XING BAY ES ON POLE B			2	2					2				2																		
VEHICLE SIGNAL Ø41						3		3		3			3																		
VEHICLE SIGNAL Ø44						3		3		3			3																		
PED SIGNAL Ø48P						2		2		2			2																		
APS PPB FOR XING BAY ES ON POLE C						2		2		2			2																		
VEHICLE SIGNAL Ø25							3	3		3			3																		
PED SIGNAL Ø29P							2	2		2			2																		
APS PPB FOR XING VAN NESS SS ON POLE D							2	2		2			2																		
VEHICLE SIGNAL Ø53															3	3															
VEHICLE SIGNAL Ø52																		3													
VEHICLE SIGNAL Ø65																		3													
PED SIGNAL Ø69P																		2													
APS PPB FOR XING VAN NESS NS ON POLE J																			2												
VEHICLE SIGNAL Ø81																					3	3									
VEHICLE SIGNAL Ø84																					3	3									
PED SIGNAL Ø88P																					2	2									
APS PPB FOR XING BAY WS ON POLE G																					2	2									
VEHICLE SIGNAL Ø45																								3							
VEHICLE SIGNAL Ø82																								3							
PED SIGNAL Ø49P																								2							
APS PPB FOR XING BAY WS ON POLE F																								2							
VEHICLE SIGNAL Ø61																									3						
VEHICLE SIGNAL Ø64																									3						
VEHICLE SIGNAL Ø67																									3						
PED SIGNAL Ø68P																										2					
APS PPB FOR XING VAN NESS SS ON POLE E																										2					
#14 NEUTRAL	3	2				3	2											2		3				2		4					
#14 SPARE			3						3	3	3		6		3									3							
TOTAL #14 WIRES	13	12	23			13	9	20	23	20		43		4	6		10	2	13	26			12	17	49						
#10 WIRES NEUTRAL			1					1	1	1		2		1	1					2						3					
#6 WIRES (120 V SERVICE)																															
#8 WIRES (120 V SERVICE)																															
#6 BSCW (SEE GENERAL NOTE 10)																															
#8 WIRES (BBS)																															
#6 GROUND (BBS)																															
TSP RECEIVER (10 CONDUCTOR CABLE)																															
CCTV CAMERA WIRES (CAT5e & 3#18)							1	1		1			1																		

I:\F. FILES\Projects\Van Ness BRT\Signal Design\CADD\CPT6401E1B5 - 100% Revised.dwg Mon Nov 23, 2015 - 12:32 pm

NO.	DATE	DESCRIPTION	REVISED	CHECKED	APPROVED

DESIGNED: *[Signature]*  
 DRAWN: *[Signature]*  
 CHECKED: *[Signature]*  
 REVIEWED: *[Signature]*  
 RECOMMENDED: *[Signature]*  
 APPROVED: *[Signature]*  
 DATE: 12/4/2015

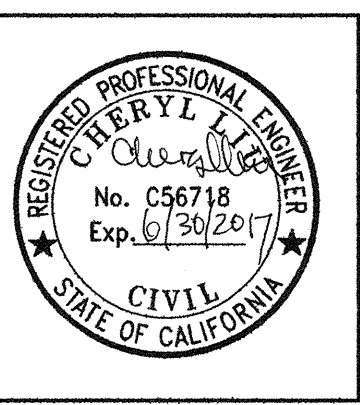

CITY AND COUNTY OF SAN FRANCISCO  
**MUNICIPAL TRANSPORTATION AGENCY**

APPROVED: *[Signature]*  
 for the DIRECTOR OF TRANSPORTATION

MUNI BUS RAPID TRANSIT SYSTEM VAN NESS CORRIDOR TRANSIT IMPROVEMENT PROJECT	1289
BAY STREET CONDUIT & WIRING SCHEDULES	ET-132.2 REVISION ET-204

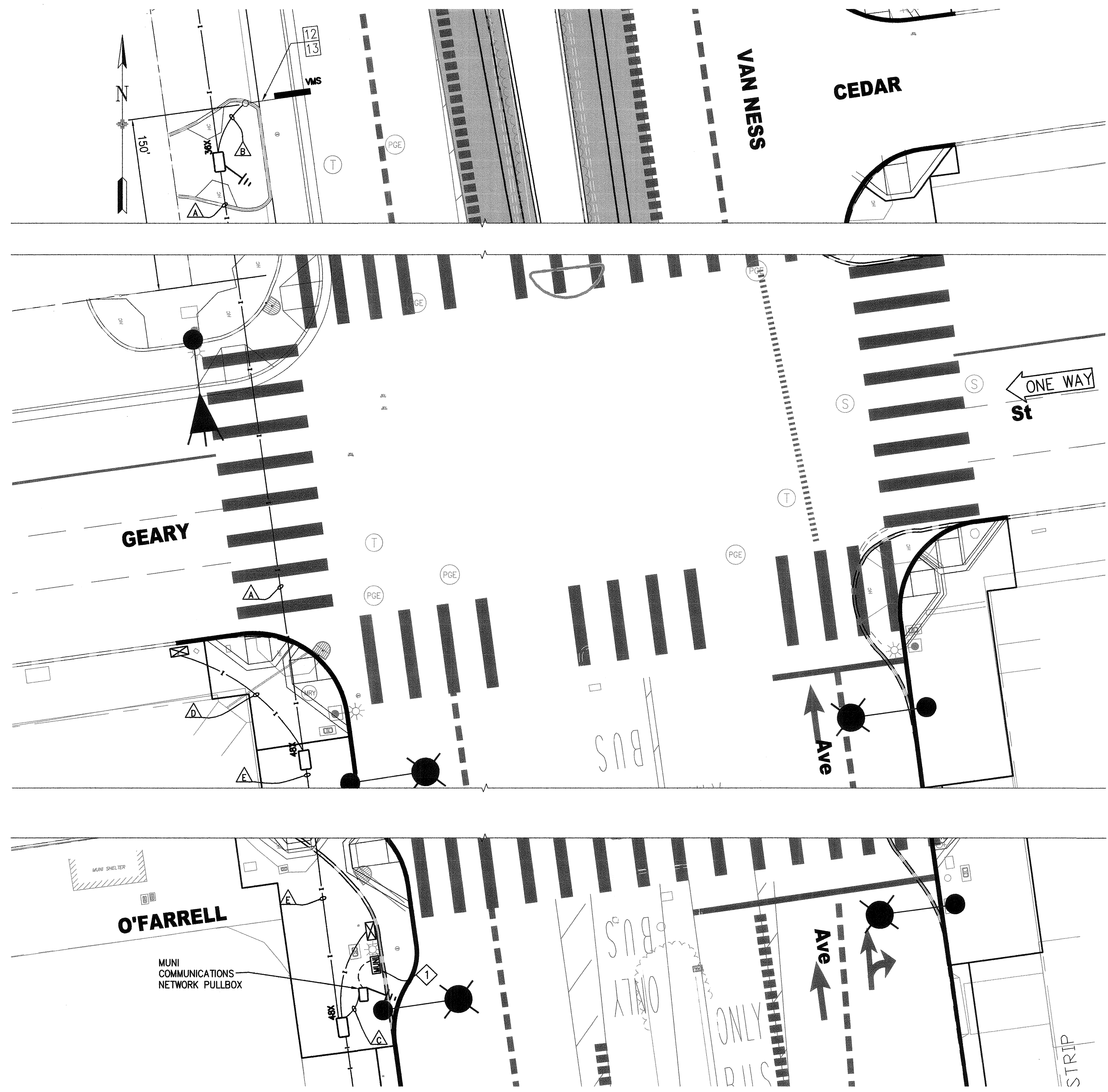

**CONDUIT NOTES:**

- △ IN ONE OF THE 4-2" HDPE CONDUITS, F/I VMS CABLES AND WIRES AS SPECIFIED BELOW:
  1. ONE (1) 6-STRAND MULTI-MODE FIBER OPTIC CABLE FURNISHED BY DAKTRONICS, INC.
  2. TWO (2) #8 AWG STRANDED COPPER CONDUCTORS
 THE AUXILIARY CONTROL PANEL WILL BE CONNECTED BY OTHERS. ALL WIRES SHALL BE SIZED ACCORDING TO DAKTRONICS' INC SPECIFICATIONS.
  
- △ IN ONE OF THE 2-2" HDPE CONDUITS, F/I VMS CABLES AND WIRES AS SPECIFIED BELOW:
  1. ONE (1) 6-STRAND MULTI-MODE FIBER OPTIC CABLE FURNISHED BY DAKTRONICS, INC.
  2. TWO (2) #8 AWG STRANDED COPPER CONDUCTORS
  3. ONE (1) BARE #6 AWG STRANDED COPPER CONDUCTOR TO VMS SIGN FOUNDATION.
 THE AUXILIARY CONTROL PANEL WILL BE CONNECTED BY OTHERS. ALL WIRES SHALL BE SIZED ACCORDING TO DAKTRONICS' INC SPECIFICATIONS.
  
- △ F/I 1-2" PVC CONDUITS WITH TWO (2) #8 AWG STRANDED COPPER CONDUCTORS TO RECEIVE POWER SERVICE FOR VMS FROM MUNI ELECTRICAL CABINET AT SOUTHWEST CORNER OF O'FARRELL/VAN NESS.
  
- △ IN ONE OF THE 2-2" HDPE CONDUIT, F/I ONE (1) 6-STRAND MULTI-MODE FIBER OPTIC CABLE FURNISHED BY DAKTRONICS, TO CONNECT TO TRAFFIC SIGNAL CONTROLLER CABINET AT SOUTHWEST CORNER OF GEARY/VAN NESS. COIL AT LEAST 3 FEET OF SLACK.
  
- △ IN ONE OF THE 4-2" HDPE CONDUIT, F/I TWO (2) #8 AWG STRANDED COPPER CONDUCTORS TO RECEIVE POWER SERVICE FOR VMS FROM MUNI ELECTRICAL CABINET AT SOUTHWEST CORNER OF O'FARRELL/VAN NESS.

**DETAIL NOTES:**

- ◇ 1 COORDINATE WITH FRANK LEUNG OF SFMTA CP&C AT (415)701-4295 FOR POWER SERVICE CONNECTION WORK AT CIRCUIT #11 PRIOR ROUTING OF CONDUITS AND CONSTRUCTION.

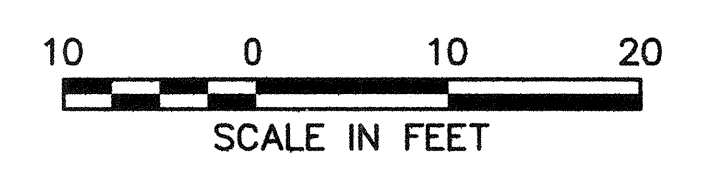

T:\E-FILES\SF\go\Projecta\Van Ness BRT\Signal Design\CADD\PTB401EBS.dwg, Kkwong, Wed Jul 08, 2015 - 5:11 pm

NO.	DATE	DESCRIPTION	REVISED	CHECKED	APPROVED
REVISIONS					

DESIGNED	<i>[Signature]</i>
DRAWN	<i>[Signature]</i>
CHECKED	<i>[Signature]</i>
REVIEWED	<i>[Signature]</i>
RECOMMENDED	<i>[Signature]</i>
APPROVED	<i>[Signature]</i>
DATE	12/4/2015

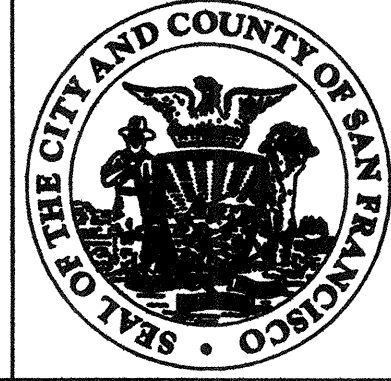

CITY AND COUNTY OF SAN FRANCISCO  
**MUNICIPAL TRANSPORTATION AGENCY**  
 APPROVED  
*[Signature]*  
 for the DIRECTOR OF TRANSPORTATION

MUNI BUS RAPID TRANSIT SYSTEM VAN NESS CORRIDOR TRANSIT IMPROVEMENT PROJECT	1289
GEARY TO POST STREET MID-BLOCK VARIABLE MESSAGE SIGN WORK	ET-133.0 ET-204

REVISION	
----------	--

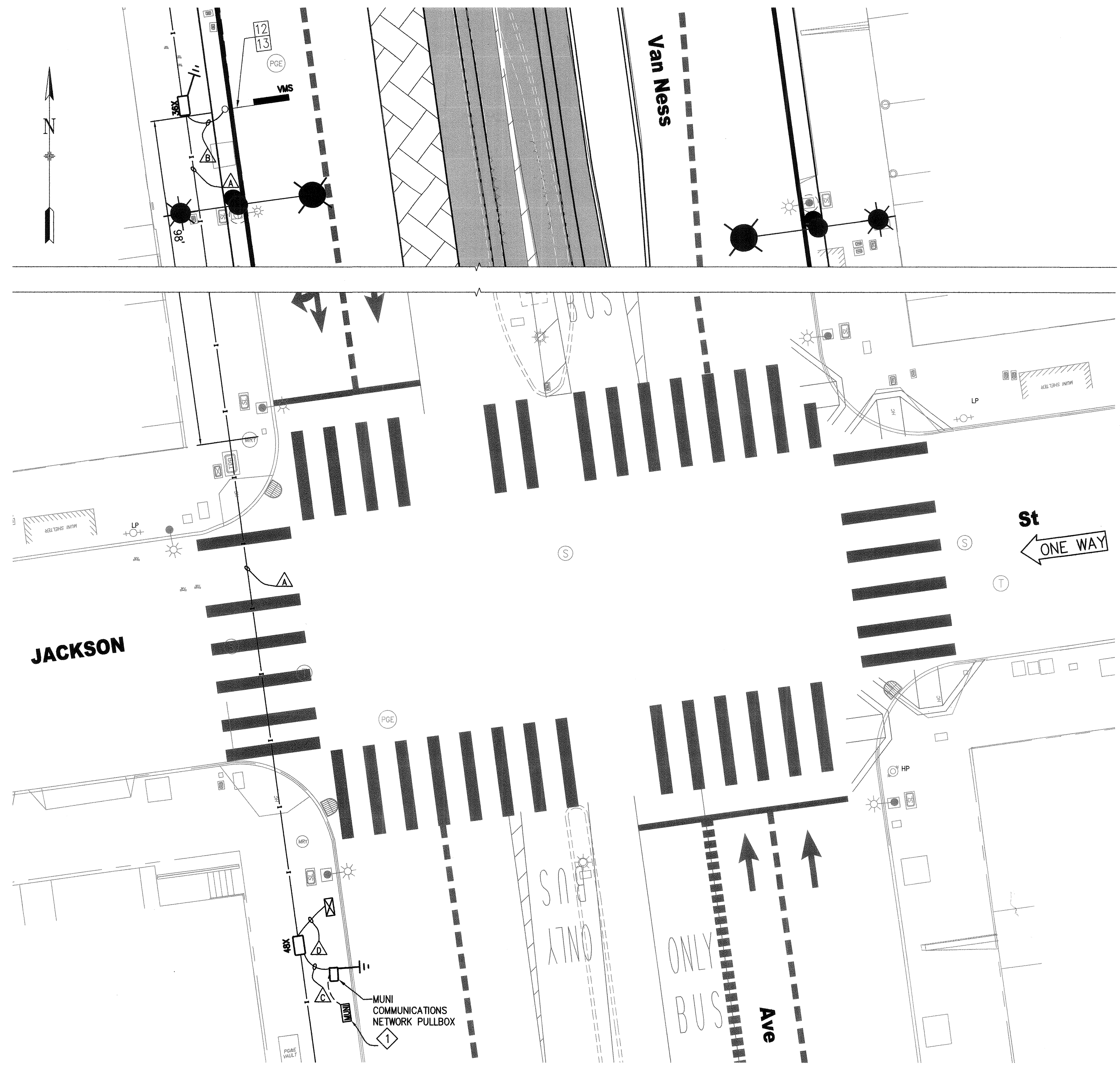

**CONDUIT NOTES:**

- △ IN ONE OF THE 4-2" HDPE CONDUITS, F/I VMS CABLES AND WIRES AS SPECIFIED BELOW:
  1. ONE (1) 6-STRAND MULTI-MODE FIBER OPTIC CABLE FURNISHED BY DAKTRONICS, INC.
  2. TWO (2) #8 AWG STRANDED COPPER CONDUCTORS
 THE AUXILIARY CONTROL PANEL WILL BE CONNECTED BY OTHERS. ALL WIRES SHALL BE SIZED ACCORDING TO DAKTRONICS' INC SPECIFICATIONS.
- △ IN ONE OF THE 2-2" HDPE CONDUITS, F/I VMS CABLES AND WIRES AS SPECIFIED BELOW:
  1. ONE (1) 6-STRAND MULTI-MODE FIBER OPTIC CABLE FURNISHED BY DAKTRONICS, INC.
  2. TWO (2) #8 AWG STRANDED COPPER CONDUCTORS
  3. ONE (1) BARE #6 AWG STRANDED COPPER CONDUCTOR TO VMS SIGN FOUNDATION.
 THE AUXILIARY CONTROL PANEL WILL BE CONNECTED BY OTHERS. ALL WIRES SHALL BE SIZED ACCORDING TO DAKTRONICS' INC SPECIFICATIONS.
- △ F/I 1-2" PVC CONDUITS WITH TWO (2) #8 AWG STRANDED COPPER CONDUCTORS TO RECEIVE POWER SERVICE FOR VMS FROM MUNI ELECTRICAL CABINET AT SOUTHWEST CORNER OF JACKSON/VAN NESS.
- △ IN ONE OF THE 2-2" HDPE CONDUIT, F/I ONE (1) 6-STRAND MULTI-MODE FIBER OPTIC CABLE FURNISHED BY DAKTRONICS, TO CONNECT TO TRAFFIC SIGNAL CONTROLLER CABINET AT SOUTHWEST CORNER OF JACKSON/VAN NESS. COIL AT LEAST 3 FEET OF SLACK.

**DETAIL NOTES:**

- ◇ COORDINATE WITH FRANK LEUNG OF SFMTA CP&C AT (415)701-4295 FOR POWER SERVICE CONNECTION WORK AT CIRCUIT #11 PRIOR ROUTING OF CONDUITS AND CONSTRUCTION.



T:\\_FILES\Sfpa\Projects\Van Ness BR\Signal Design\CADD\CP16401E1BS.dwg Monong Tue Jul 07 2015 3:56 pm

NO.	DATE	DESCRIPTION	REVISED	CHECKED	APPROVED

DESIGNED: *[Signature]*  
 DRAWN: *[Signature]*  
 CHECKED: *[Signature]*  
 REVIEWED: *[Signature]*  
 RECOMMENDED: *[Signature]*  
 APPROVED: *[Signature]*  
 DATE: 12/4/2015

REGISTERED PROFESSIONAL ENGINEER  
 CHESTER L. LEUNG  
 No. C56718  
 Exp. 6/30/2015  
 CIVIL  
 STATE OF CALIFORNIA

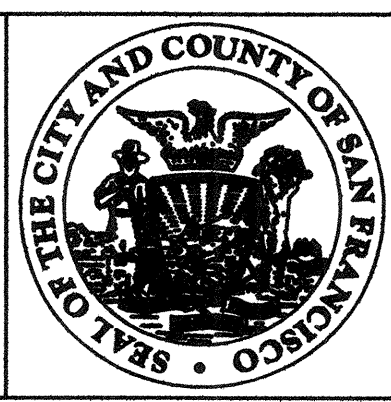
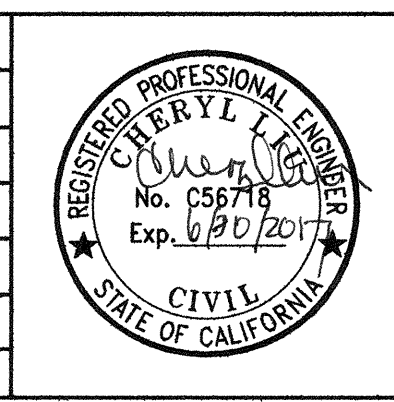

CITY AND COUNTY OF SAN FRANCISCO  
**MUNICIPAL TRANSPORTATION AGENCY**  
 APPROVED: *[Signature]*  
 for the DIRECTOR OF TRANSPORTATION

MUNI BUS RAPID TRANSIT SYSTEM  
 VAN NESS CORRIDOR TRANSIT IMPROVEMENT PROJECT  
 JACKSON STREET  
 VARIABLE MESSAGE SIGN WORK

1289  
 ET-134.0  
 ET-204



T:\T.E. FILES\SF\Proj\Van Ness BRT\Signal Design\CAOD\Fiber\CP16401\_ET-200\_070215.dwg, kkwong, Thu Jul 02, 2015 - 12:31 pm

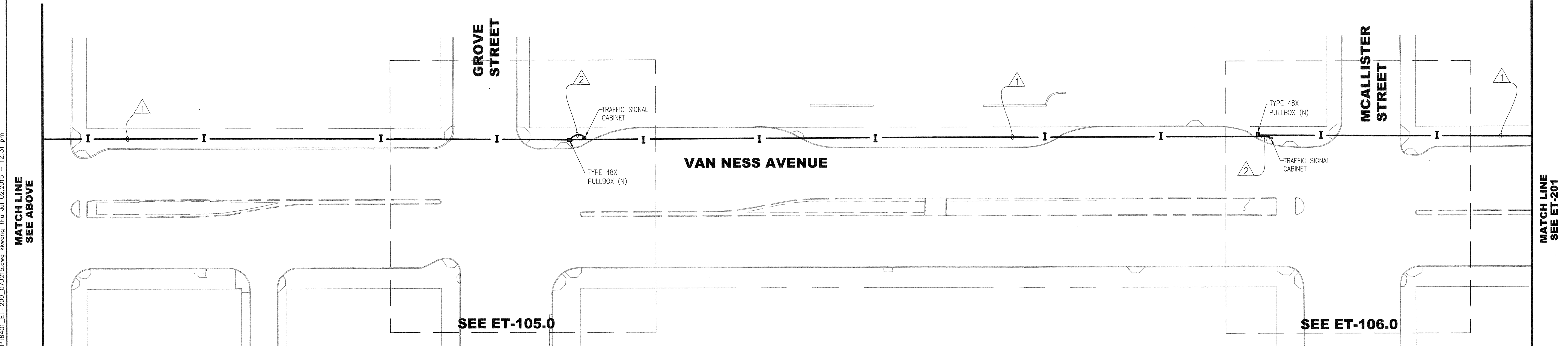
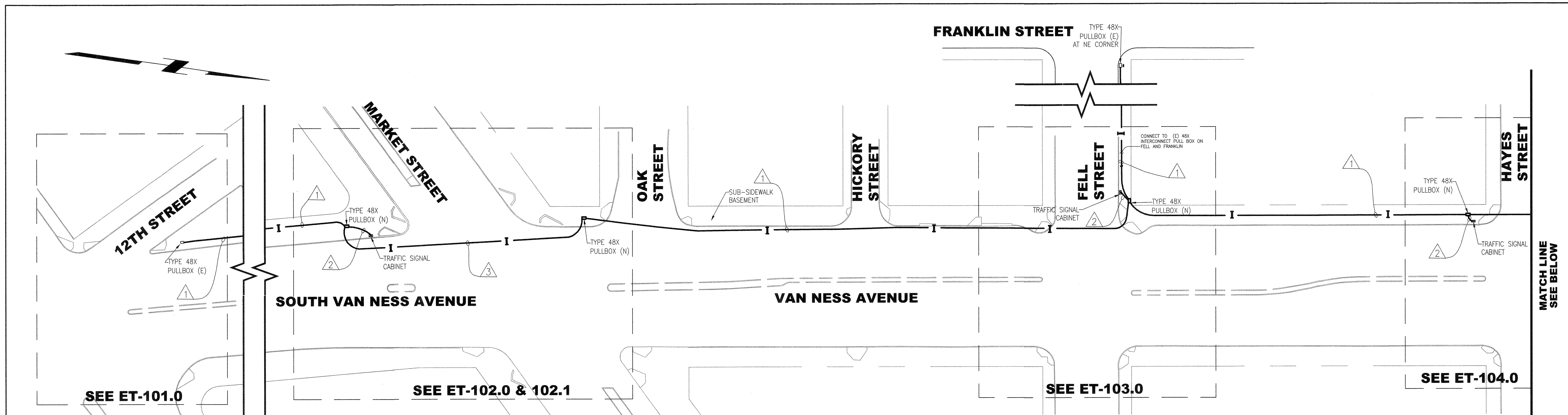

**NEW CONDUITS:**

- △ F/1 4-2" HDPE CONDUITS WITH PULL TAPE. IN ONE OF THE CONDUITS, F/1 2#8 AWG STRANDED COPPER CONDUCTORS WITH TYPE UF INSULATION (ONE WIRE SHALL BE BLACK AND OTHER SHALL BE WHITE). 1#10 AWG STRANDED WIRE WITH GREEN INSULATION.
- △ F/1 4-2" GRS CONDUITS WITH PULL TAPE. IN ONE OF THE CONDUITS, F/1 2#8 AWG STRANDED COPPER CONDUCTORS WITH TYPE UF INSULATION (ONE WIRE SHALL BE BLACK AND OTHER SHALL BE WHITE). 1#10 AWG STRANDED WIRE WITH GREEN INSULATION.
- △ F/1 2-2" HDPE CONDUITS WITH PULL TAPE FROM THE TYPE 48X PULLBOX TO THE TRAFFIC SIGNAL CABINET. IN ONE OF THE CONDUITS, F/1 2#8 AWG STRANDED COPPER CONDUCTORS WITH TYPE UF INSULATION (ONE WIRE SHALL BE BLACK AND OTHER SHALL BE WHITE). 1#10 AWG STRANDED WIRE WITH GREEN INSULATION.

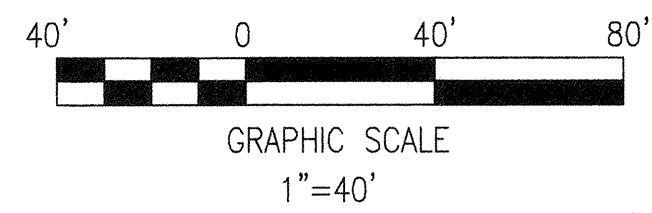

NO.	DATE	DESCRIPTION	REVISED	CHECKED	APPROVED
REVISIONS					

DESIGNED	<i>R King</i>
DRAWN	<i>R King</i>
CHECKED	<i>Chandler</i>
REVIEWED	<i>Chandler</i>
RECOMMENDED	<i>Chandler</i>
APPROVED	<i>Polar</i>
DATE	12/14/2015

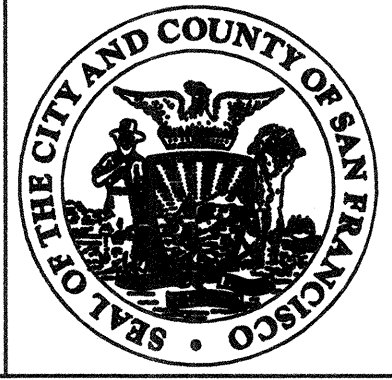

CITY AND COUNTY OF SAN FRANCISCO  
**MUNICIPAL TRANSPORTATION AGENCY**

APPROVED  
*[Signature]*  
for the DIRECTOR OF TRANSPORTATION

MUNI BUS RAPID TRANSIT SYSTEM		1289
VAN NESS CORRIDOR TRANSIT IMPROVEMENT PROJECT		
INTERCONNECT ROUTING VAN NESS AVE 12TH STREET TO MCALLISTER STREET	ET-200 ET-204	REVISION

T:\E\_FILES\SE\Projects\Van Ness BRT\Signal Design\CADD\Fiber\CPT6401\_ET-200\_070215.dwg, kkwong, Thu Jul 02, 2015 - 12:31 pm

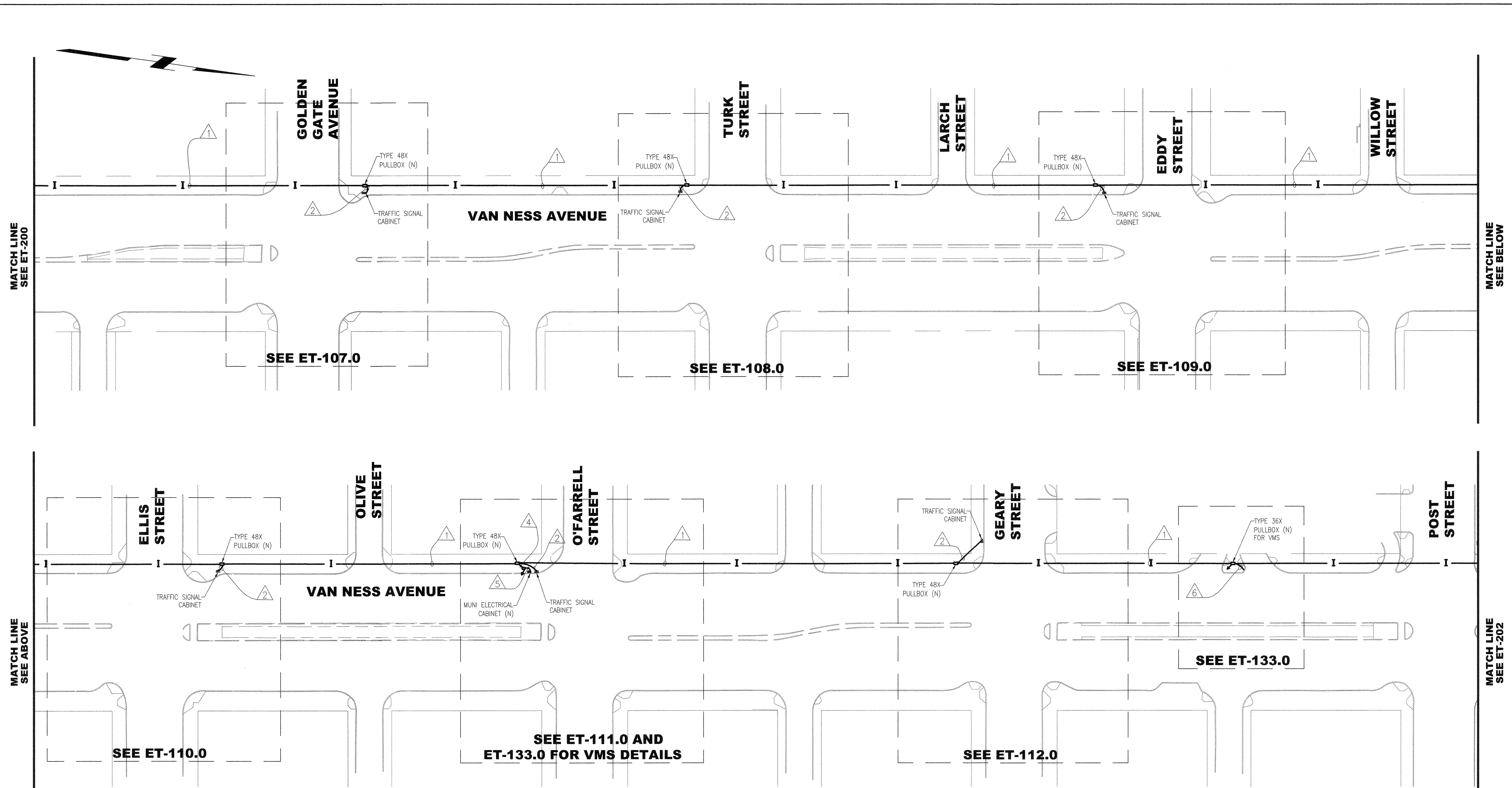

MATCH LINE  
SEE ET-200

MATCH LINE  
SEE BELOW

MATCH LINE  
SEE ABOVE

MATCH LINE  
SEE ET-202

SEE ET-107.0

SEE ET-108.0

SEE ET-109.0

SEE ET-110.0

SEE ET-111.0 AND  
ET-133.0 FOR VMS DETAILS

SEE ET-112.0

SEE ET-133.0

**NEW CONDUITS:**

- △ F/1 4-2" HDPE CONDUITS WITH PULL TAPE. IN ONE OF THE CONDUITS, F/1 2#8 AWG STRANDED COPPER CONDUCTORS WITH TYPE UF INSULATION (ONE WIRE SHALL BE BLACK AND OTHER SHALL BE WHITE). 1#10 AWG STRANDED WIRE WITH GREEN INSULATION.
- △ F/1 2-2" HDPE CONDUITS WITH PULL TAPE. IN ONE OF THE CONDUITS, F/1 2#8 AWG STRANDED COPPER CONDUCTORS WITH TYPE UF INSULATION (ONE WIRE SHALL BE BLACK AND OTHER SHALL BE WHITE). 1#10 AWG STRANDED WIRE WITH GREEN INSULATION.

- △ F/1 2-2" HDPE CONDUITS WITH PULL TAPE FROM THE TYPE 48X PULLBOX TO THE TRAFFIC SIGNAL CABINET. IN ONE OF THE CONDUITS, F/1 2#8 AWG STRANDED COPPER CONDUCTORS WITH TYPE UF INSULATION (ONE WIRE SHALL BE BLACK AND OTHER SHALL BE WHITE). 1#10 AWG STRANDED WIRE WITH GREEN INSULATION.
- △ MUNI CABINET CONDUIT. SEE CN SHEETS FOR DETAILS.
- △ F/1 2-2" HDPE CONDUITS WITH PULL TAPE.

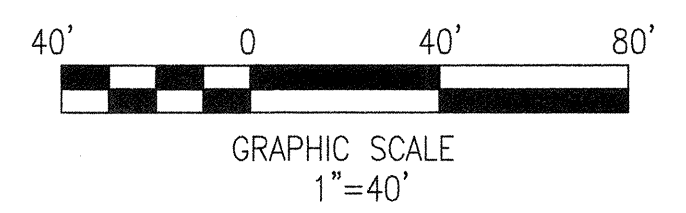

NO.	DATE	DESCRIPTION	REVISED	CHECKED	APPROVED
REVISIONS					

DESIGNED	<i>[Signature]</i>
DRAWN	<i>[Signature]</i>
CHECKED	<i>[Signature]</i>
REVIEWED	<i>[Signature]</i>
RECOMMENDED	<i>[Signature]</i>
APPROVED	<i>[Signature]</i>
DATE	12/4/2015



CITY AND COUNTY OF SAN FRANCISCO  
**MUNICIPAL TRANSPORTATION AGENCY**

*[Signature]*  
APPROVED  
for the DIRECTOR OF TRANSPORTATION

MUNI BUS RAPID TRANSIT SYSTEM VAN NESS CORRIDOR TRANSIT IMPROVEMENT PROJECT		1289
INTERCONNECT ROUTING VAN NESS AVE MCALLISTER STREET TO POST STREET		ET-201 ET-204
		REVISION

T:\T\_E\_FILES\Sp\Projects\Van Ness BRT\Signal Design\CA00\Van Ness ET-200\_070215.dwg, kkwang, Thu Jul 02, 2015 - 12:31 pm

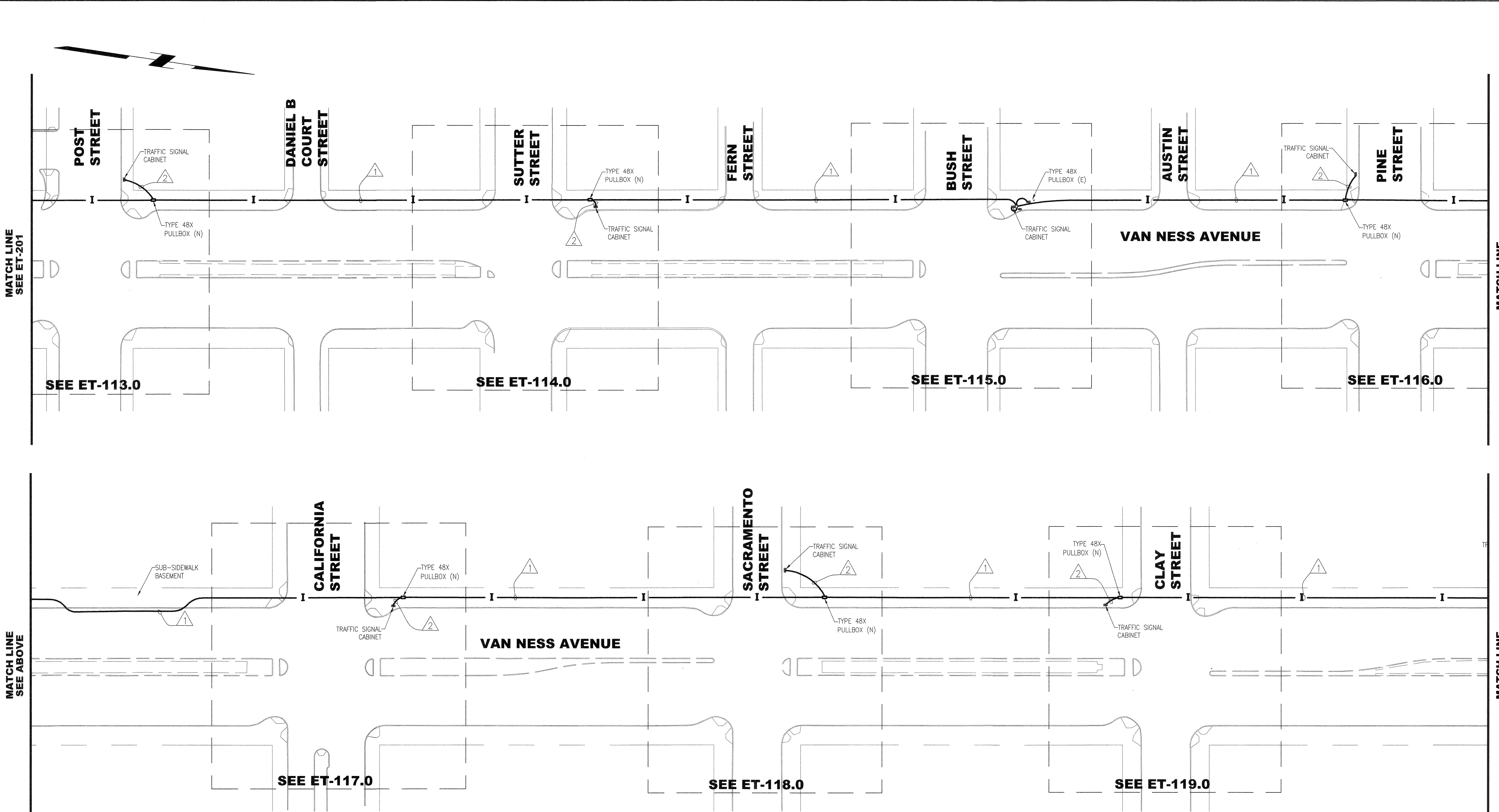

SEE ET-113.0

SEE ET-114.0

SEE ET-115.0

SEE ET-116.0

SEE ET-117.0

SEE ET-118.0

SEE ET-119.0

**NEW CONDUITS:**

△ F/1 4-4" HDPE CONDUITS WITH PULL TAPE. IN ONE OF THE CONDUITS, F/1 2#8 AWG STRANDED COPPER CONDUCTORS WITH TYPE UF INSULATION (ONE WIRE SHALL BE BLACK AND OTHER SHALL BE WHITE). 1#10 AWG STRANDED WIRE WITH GREEN INSULATION.

△ F/1 2-2" HDPE CONDUITS WITH PULL TAPE FROM THE TYPE 48X PULLBOX TO THE TRAFFIC SIGNAL CABINET. IN ONE OF THE CONDUITS, F/1 2#8 AWG STRANDED COPPER CONDUCTORS WITH TYPE UF INSULATION (ONE WIRE SHALL BE BLACK AND OTHER SHALL BE WHITE). 1#10 AWG STRANDED WIRE WITH GREEN INSULATION.

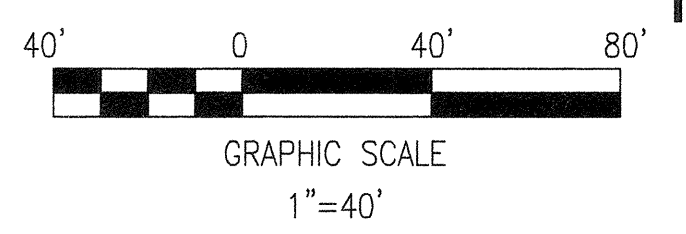

NO.	DATE	DESCRIPTION	REVISED	CHECKED	APPROVED
REVISIONS					

DESIGNED *R King*  
 DRAWN *R King*  
 CHECKED *Cherrellin*  
 REVIEWED *Cherrellin*  
 RECOMMENDED *for review*  
 APPROVED *Poles*  
 DATE *7/24/2015*



CITY AND COUNTY OF SAN FRANCISCO  
**MUNICIPAL TRANSPORTATION AGENCY**  
 APPROVED *[Signature]*  
 for the DIRECTOR OF TRANSPORTATION

MUNI BUS RAPID TRANSIT SYSTEM		1289
VAN NESS CORRIDOR TRANSIT IMPROVEMENT PROJECT		
INTERCONNECT ROUTING VAN NESS AVE POST STREET TO CLAY STREET	ET-202 ET-204	REVISION

T:\T\_E\_FILES\SF\Proj\Van Ness BRT\Signal Design\CA00\Fiber\CP16401\_ET-200\_070215.dwg kkwong Thu Jul 02 2015 - 12:31 pm

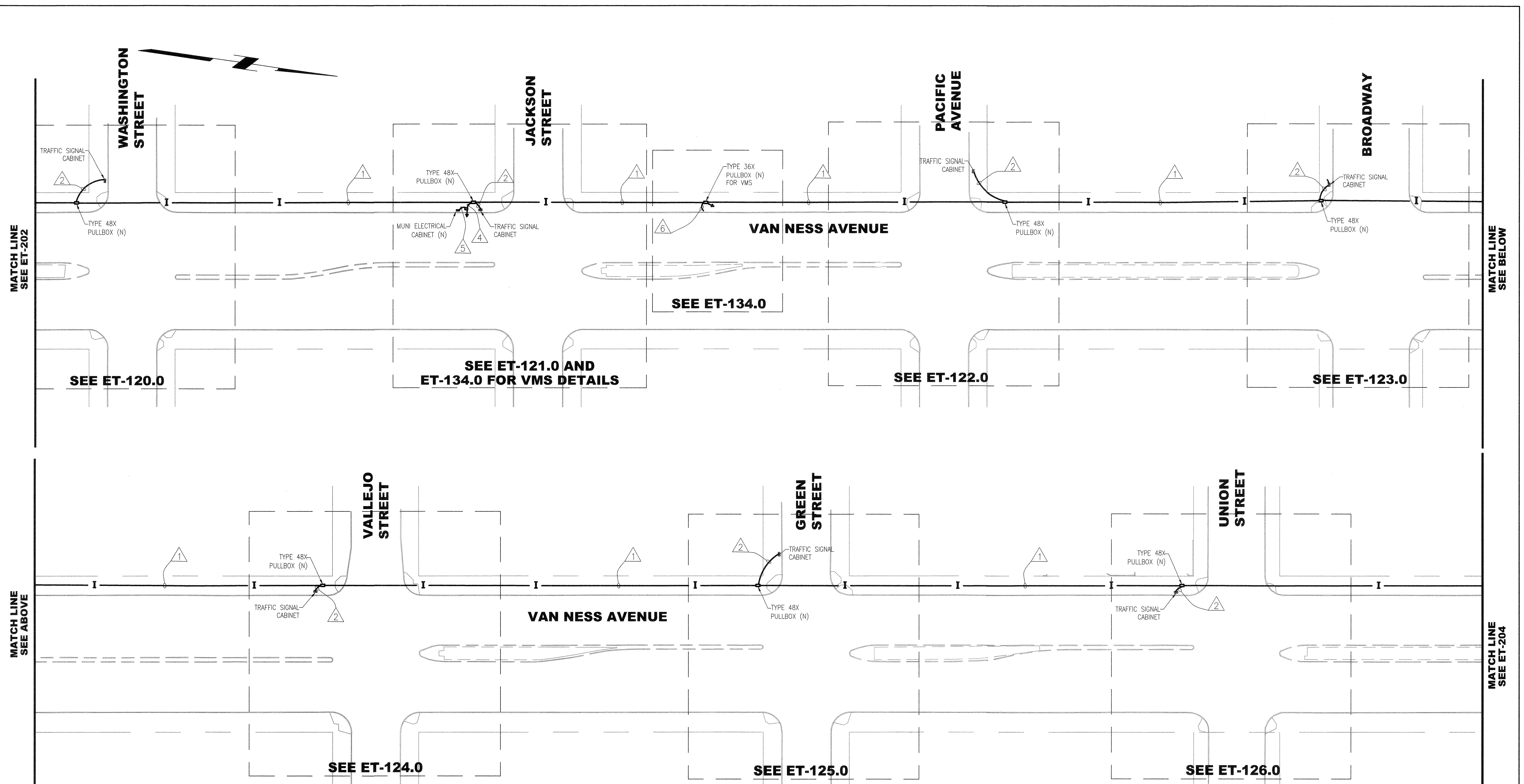

**NEW CONDUITS:**

- △ F/1 4-2" HDPE CONDUITS WITH PULL TAPE. IN ONE OF THE CONDUITS, F/1 2#8 AWG STRANDED COPPER CONDUCTORS WITH TYPE UF INSULATION (ONE WIRE SHALL BE BLACK AND OTHER SHALL BE WHITE). 1#10 AWG STRANDED WIRE WITH GREEN INSULATION.
- △ F/1 2-2" HDPE CONDUITS WITH PULL TAPE. IN ONE OF THE CONDUITS, F/1 2#8 AWG STRANDED COPPER CONDUCTORS WITH TYPE UF INSULATION (ONE WIRE SHALL BE BLACK AND OTHER SHALL BE WHITE). 1#10 AWG STRANDED WIRE WITH GREEN INSULATION.
- △ F/1 2-2" HDPE CONDUITS WITH PULL TAPE FROM THE TYPE 48X PULLBOX TO THE TRAFFIC SIGNAL CABINET. IN ONE OF THE CONDUITS, F/1 2#8 AWG STRANDED COPPER CONDUCTORS WITH TYPE UF INSULATION (ONE WIRE SHALL BE BLACK AND OTHER SHALL BE WHITE). 1#10 AWG STRANDED WIRE WITH GREEN INSULATION.
- △ MUNI CABINET CONDUIT. SEE CN SHEETS FOR DETAILS.
- △ F/1 2-2" HDPE CONDUITS WITH PULL TAPE.

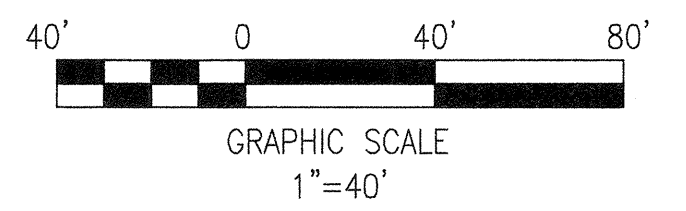

NO.	DATE	DESCRIPTION	REVISED	CHECKED	APPROVED

DESIGNED	<i>[Signature]</i>
DRAWN	<i>[Signature]</i>
CHECKED	<i>[Signature]</i>
REVIEWED	<i>[Signature]</i>
RECOMMENDED	<i>[Signature]</i>
APPROVED	<i>[Signature]</i>
DATE	12/4/2015

REGISTERED PROFESSIONAL ENGINEER  
 CHERYL L. CHAMBERLAIN  
 No. C56718  
 Exp. 6/30/2018  
 CIVIL  
 STATE OF CALIFORNIA

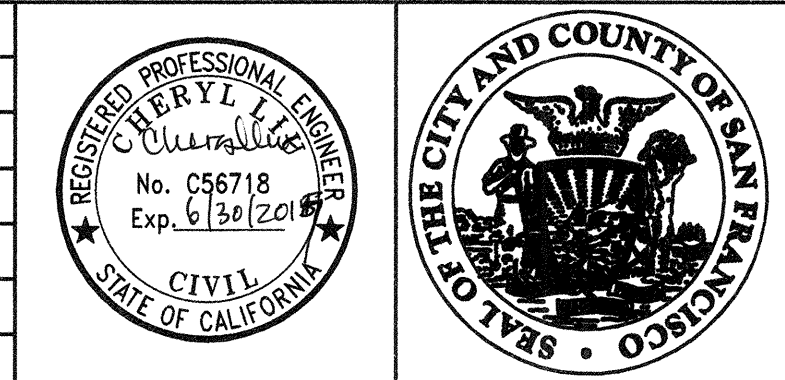

CITY AND COUNTY OF SAN FRANCISCO  
**MUNICIPAL TRANSPORTATION AGENCY**  
 APPROVED  
*[Signature]*  
 for the DIRECTOR OF TRANSPORTATION

MUNI BUS RAPID TRANSIT SYSTEM  
 VAN NESS CORRIDOR TRANSIT IMPROVEMENT PROJECT  
 INTERCONNECT ROUTING  
 VAN NESS AVE  
 WASHINGTON STREET TO UNION STREET

1289	REVISION
ET-203	
ET-204	

T:\T\_E\_FILES\SF\Projects\Van Ness BRT\Signal Design\CADD\Fiber\CP16401\_ET-200\_070215.dwg, Kkwong Thu Jul 02, 2015 - 12:32 pm

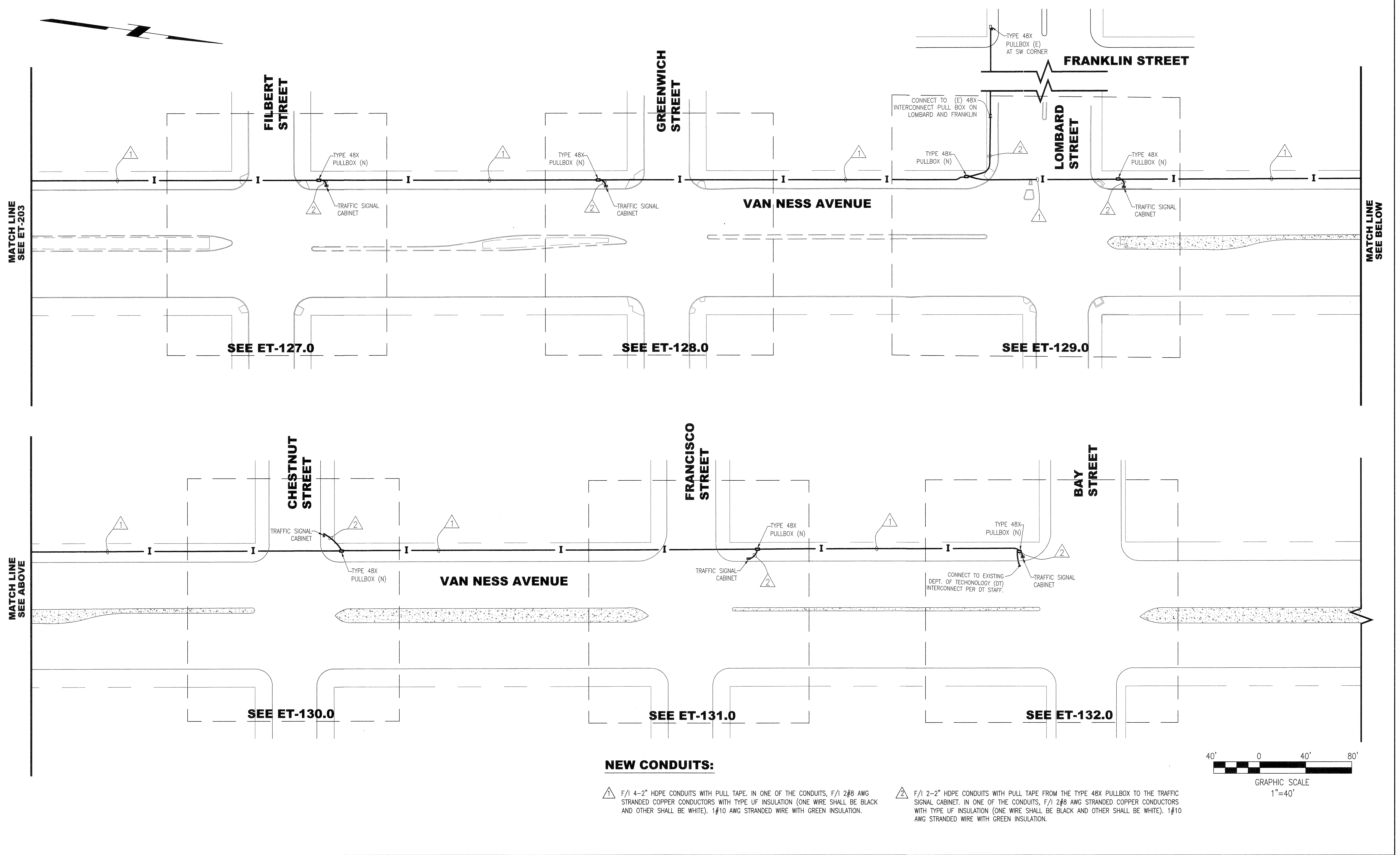

**NEW CONDUITS:**

△ F/1 4-2" HDPE CONDUITS WITH PULL TAPE. IN ONE OF THE CONDUITS, F/1 2#8 AWG STRANDED COPPER CONDUCTORS WITH TYPE UF INSULATION (ONE WIRE SHALL BE BLACK AND OTHER SHALL BE WHITE). 1#10 AWG STRANDED WIRE WITH GREEN INSULATION.

△ F/1 2-2" HDPE CONDUITS WITH PULL TAPE FROM THE TYPE 48X PULLBOX TO THE TRAFFIC SIGNAL CABINET. IN ONE OF THE CONDUITS, F/1 2#8 AWG STRANDED COPPER CONDUCTORS WITH TYPE UF INSULATION (ONE WIRE SHALL BE BLACK AND OTHER SHALL BE WHITE). 1#10 AWG STRANDED WIRE WITH GREEN INSULATION.

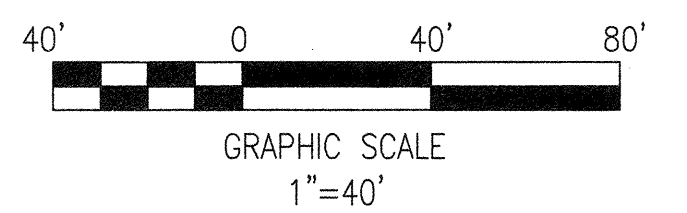

NO.	DATE	DESCRIPTION	REVISED	CHECKED	APPROVED
REVISIONS					

DESIGNED	<i>[Signature]</i>
DRAWN	<i>[Signature]</i>
CHECKED	<i>[Signature]</i>
REVIEWED	<i>[Signature]</i>
RECOMMENDED	<i>[Signature]</i>
APPROVED	<i>[Signature]</i>
DATE	12/4/15

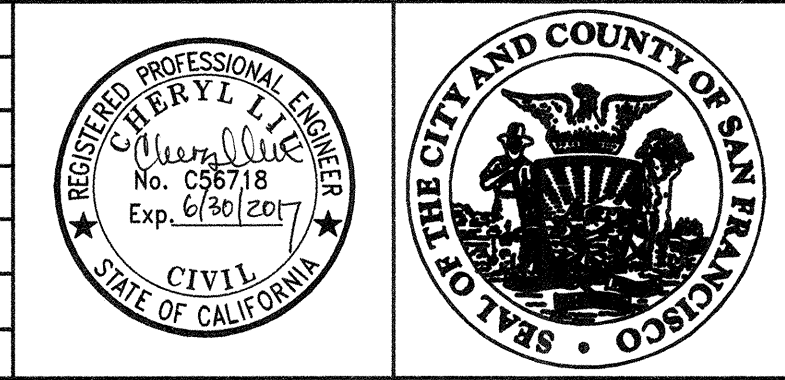

CITY AND COUNTY OF SAN FRANCISCO  
**MUNICIPAL TRANSPORTATION AGENCY**

APPROVED  
*[Signature]*  
 For the DIRECTOR OF TRANSPORTATION

MUNI BUS RAPID TRANSIT SYSTEM		1289
VAN NESS CORRIDOR TRANSIT IMPROVEMENT PROJECT		
INTERCONNECT ROUTING VAN NESS AVE UNION STREET TO BAY STREET	ET-204	REVISION
	ET-204	