































































Appendix A: 8th Avenue Screenline Volume and Travel Time Results

Origin Zone Name	Destination Zone Name	% of Total Volume		Percent of OD Volume		Travel Time		Fall 2019 Total Volume	Fall 2019 Volume Via 8th Ave	Fall 2019 Median Travel Time (mins)	Fall 2021 Median Travel Time (mins)
		on 8th Ave		Using 8th Ave		Travel Time Change (%)	Change (mins)				
Richmond Subarea3	North Inner Sunset	2.8%	46%		+6%	+1.36	1278	583	21.51587302	22.87755102	
North Inner Sunset	Richmond Subarea3	2.7%	37%		-2%	-0.35	1533	565	21.36363636	21.0170068	
Golden Gate Park	Richmond Subarea3	2.3%	35%		-11%	-1.87	1376	483	17.40410959	15.53191489	
Richmond Subarea3	Golden Gate Park	1.9%	44%		-27%	-5.20	916	404	19.61111111	14.41176471	
South Central	Richmond Subarea3	1.6%	36%		-15%	-6.69	974	347	44.96153846	38.26923077	
Richmond Subarea3	Outer Sunset	1.6%	11%		-10%	-2.67	3208	337	26.81168831	24.14	
Richmond Subarea3	Ingleside	1.4%	14%		-3%	-0.97	2169	300	33.925	32.95833333	
Richmond Subarea3	South Central	1.4%	30%		-4%	-1.71	973	294	46.47674419	44.765625	
Golden Gate Park	SF screenline north	1.3%	31%		-5%	-0.97	909	282	18.69117647	17.72147651	
SF screenline south	Richmond Subarea3	1.1%	8%		-16%	-5.36	2965	238	33.51351351	28.15686275	
SF screenline north	Golden Gate Park	1.1%	34%		-14%	-2.78	682	235	20.51136364	17.73566879	
Ingleside	Richmond Subarea3	1.1%	10%		-9%	-3.06	2349	233	33.66901408	30.60588235	
Downtown	SF screenline north	1.0%	3%		-25%	-8.36	6788	217	33.66	25.29807692	
South Inner Sunset	Richmond Subarea3	1.0%	25%		-6%	-1.33	866	214	22.58433735	21.25862069	
Golden Gate Park	Western Addition	1.0%	9%		-0%	-0.04	2375	203	21.19117647	21.15384615	
Outer Sunset	Richmond Subarea3	0.9%	7%		-4%	-0.96	2886	195	23.85526316	22.89622642	
Richmond Subarea3	South Bayshore	0.9%	29%		-1%	-0.31	676	193	48.90764331	48.59689214	
SF screenline north	North Inner Sunset	0.9%	15%		-2%	-0.54	1252	189	25.35294118	24.81360947	
Northeast	SF screenline north	0.9%	3%		-21%	-4.84	6460	189	23.56666667	18.725	
Richmond Subarea2	Golden Gate Park	0.9%	27%		+12%	+2.10	678	184	17.26388889	19.36585366	
Golden Gate Park	Golden Gate Park	0.9%	10%		-4%	-0.66	1737	182	15.84042553	15.17768595	
Western Addition	Golden Gate Park	0.9%	9%		-1%	-0.15	2014	181	22.48	22.33333333	
Golden Gate Park	Richmond Subarea2	0.9%	19%		-4%	-0.60	927	180	16.325	15.72368421	
South of Market	Richmond Subarea1	0.8%	11%		-22%	-10.89	1569	172	48.97928994	38.09375	
Richmond Subarea3	South Inner Sunset	0.8%	24%		+8%	+2.13	716	171	26.49056604	28.61764706	
Richmond Subarea3	SF screenline south	0.8%	6%		+6%	+1.87	2838	169	31.234375	33.1	
Outer Sunset	Western Addition	0.8%	3%		-14%	-4.52	6208	169	31.5	26.98387097	
Central	Richmond Subarea3	0.8%	23%		-2%	-0.53	706	165	30.60377358	30.06896552	
Golden Gate Park	Northeast	0.7%	18%		-15%	-6.39	854	157	42	35.60810811	
North Inner Sunset	SF screenline north	0.7%	10%		-14%	-3.21	1607	157	22.51075269	19.29787234	
Richmond Subarea2	North Inner Sunset	0.7%	15%		-14%	-3.08	996	152	22.73376623	19.65346535	
Western Addition	Outer Sunset	0.7%	2%		-8%	-2.46	6284	152	32.75423729	30.29104478	
Mission	Richmond Subarea2	0.7%	19%		-11%	-4.58	801	151	41.03333333	36.45238095	
North Inner Sunset	Richmond Subarea2	0.7%	15%		-20%	-4.14	1022	149	20.53658537	16.39726027	
Mission	Richmond Subarea1	0.7%	14%		-14%	-6.29	1063	146	43.58860759	37.29411765	
South of Market	Richmond Subarea3	0.7%	8%		-34%	-16.12	1803	142	47.87209302	31.75252525	
Richmond Subarea2	Central	0.7%	25%		-8%	-2.41	570	141	31.8	29.39473684	
South Bayshore	Richmond Subarea3	0.7%	23%		-0%	-0.12	615	141	48.73426573	48.6149635	
Richmond Subarea1	SF screenline east	0.6%	17%		-0%	-0.07	819	137	48.75127334	48.68512397	
SF screenline east	Richmond Subarea1	0.6%	17%		-12%	-5.08	809	136	43.6	38.515625	
SF screenline east	Richmond Subarea2	0.6%	16%		-9%	-3.93	771	123	43.51190476	39.57792208	
South of Market	Richmond Subarea2	0.6%	9%		-19%	-8.76	1277	119	47.1984127	38.43650794	
Richmond Subarea1	South of Market	0.6%	7%		-0%	-0.14	1750	118	48.72413793	48.58728653	
South Bayshore	Richmond Subarea1	0.6%	15%		-10%	-4.60	795	116	48.34375	43.74561404	
Buena Vista	SF screenline north	0.6%	14%		-12%	-3.43	824	116	29.02631579	25.5974026	
Richmond Subarea3	Central	0.5%	18%		+6%	+1.73	622	114	30.25862069	31.98837209	
Central	Richmond Subarea2	0.5%	20%		-22%	-8.68	549	111	38.65384615	29.97169811	

Origin Zone Name	Destination Zone Name	% of Total Volume		Percent of OD Volume		Travel Time		Fall 2019 Total Volume	Fall 2019 Volume Via 8th Ave	Fall 2019 Median Travel Time (mins)	Fall 2021 Median Travel Time (mins)
		on 8th Ave		Using 8th Ave		Travel Time Change (%)	Change (mins)				
North Inner Sunset	Western Addition	0.5%	3%		-17%	-4.52	3525	109	25.81818182	21.3030303	
Mission	Richmond Subarea3	0.5%	8%		-7%	-2.62	1356	108	37.5	34.88356164	
Outer Sunset	Northeast	0.5%	3%		-10%	-4.33	3308	108	44.36111111	40.03125	
Richmond Subarea2	South Central	0.5%	12%		+7%	+3.01	883	107	45.60526316	48.61948529	
SF screenline east	Richmond Subarea3	0.5%	9%		-24%	-9.36	1128	107	38.32432432	28.96031746	
Richmond Subarea3	Mission	0.5%	8%		-15%	-5.96	1250	101	38.75531915	32.8	
Richmond Subarea2	South of Market	0.5%	7%		+7%	+3.08	1350	101	43.75862069	46.8372093	
Buena Vista	Richmond Subarea3	0.5%	8%		+3%	+0.64	1156	98	22.64814815	23.29166667	
SF screenline east	Richmond LandsEnd	0.5%	38%				252	97		36.10913706	
Downtown	Golden Gate Park	0.5%	12%		-11%	-4.20	828	97	38.68421053	34.48684211	
Richmond Subarea2	Mission	0.5%	12%		-1%	-0.51	806	97	39.29012346	38.7804878	
SF screenline north	Buena Vista	0.5%	13%		-11%	-3.19	736	96	28.48275862	25.29230769	
Western Addition	SF screenline north	0.5%	2%		-15%	-3.34	3977	96	21.68421053	18.34705882	
Richmond Subarea1	South Bayshore	0.5%	14%		+0%	+0.19	687	95	48.95288754	49.14130435	
Downtown	Northeast	0.4%	0%		-16%	-3.56	42297	93	22.30327869	18.74358974	
Western Addition	North Inner Sunset	0.4%	2%		-3%	-0.80	3731	92	24.72033898	23.91791045	
Richmond Subarea2	SF screenline east	0.4%	12%		+1%	+0.43	735	91	47.59448819	48.02631579	
Richmond Subarea2	South Bayshore	0.4%	21%		-0%	-0.06	419	89	48.69473684	48.63577982	
Richmond Subarea3	Buena Vista	0.4%	8%		+6%	+1.54	1157	88	24.08571429	25.625	
Richmond Subarea2	Buena Vista	0.4%	13%		-7%	-1.82	650	87	25	23.18095238	
SF screenline south	Western Addition	0.4%	1%		-15%	-5.11	11060	85	34.47402597	29.36585366	
Northeast	Golden Gate Park	0.4%	14%		+2%	+0.78	588	84	38.08490566	38.86363636	
Golden Gate Park	Richmond Subarea4	0.4%	11%		-13%	-2.57	733	84	20.23529412	17.6656051	
Richmond Subarea3	SF screenline east	0.4%	8%		-8%	-3.68	975	82	44.82142857	41.14150943	
SF screenline north	Central	0.4%	10%		+1%	+0.35	840	81	35.09793814	35.44827586	
Richmond Subarea2	SF screenline south	0.4%	3%		+7%	+2.01	2548	81	28.43939394	30.44936709	
South Central	Richmond Subarea1	0.4%	7%		-4%	-1.95	1166	80	43.51470588	41.56779661	
Western Addition	Richmond Subarea2	0.4%	2%		-8%	-1.91	4026	80	23.06470588	21.15	
SF screenline south	Downtown	0.4%	0%		-24%	-7.76	23137	80	32.65277778	24.89534884	
Richmond Subarea4	Golden Gate Park	0.4%	13%		+12%	+2.35	586	78	19.47368421	21.82743363	
Ingleside	Western Addition	0.4%	2%		-7%	-2.68	5026	78	39.71428571	37.03409091	
Bernal Heights	Richmond Subarea3	0.4%	35%				217	76	46.18085106		
Downtown	Outer Sunset	0.4%	1%		-12%	-5.97	5626	76	48.16	42.19014085	
SF screenline south	SF screenline north	0.4%	1%		-4%	-1.12	8384	76	29.6056338	28.48787879	
Richmond Subarea1	South Central	0.4%	9%		-8%	-3.69	872	75	46.72807018	43.03658537	
Downtown	Richmond Subarea3	0.4%	2%		-24%	-8.49	4403	75	34.77118644	26.2826087	
South Bayshore	Richmond Subarea2	0.4%	19%		-8%	-3.59	381	74	44.84285714	41.2518797	
South Central	Richmond Subarea2	0.4%	9%		+11%	+4.84	796	74	43.74444444	48.58429119	
Northeast	Northeast	0.4%	0%		-13%	-2.51	48096	74	19.03521127	16.52380952	
Western Addition	Richmond Subarea3	0.3%	1%		-16%	-3.05	6922	73	18.97619048	15.92682927	
South Central	Western Addition	0.3%	1%		-5%	-1.99	4848	72	38.40243902	36.4122807	
Outer Sunset	Richmond Subarea4	0.3%	5%		-5%	-1.31	1573	71	28.58108108	27.27358491	
Outer Sunset	Downtown	0.3%	1%		-12%	-5.10	5821	71	43.35	38.25257732	
Downtown	North Inner Sunset	0.3%	3%		-16%	-6.36	2557	70	38.84375	32.48717949	
Buena Vista	Richmond Subarea2	0.3%	12%		-4%	-1.13	588	68	26.875	25.74468085	
Marina	Golden Gate Park	0.3%	11%		-11%	-3.49	593	68	31.17391304	27.68666667	
Golden Gate Park	Buena Vista	0.3%	6%		-17%	-3.54	1205	68	20.35185185	16.80769231	

Origin Zone Name	Destination Zone Name	% of Total Volume		Travel Time		Fall 2019 Total Volume	Fall 2019 Volume Via 8th Ave	Fall 2019 Median Travel Time (mins)	Fall 2021 Median Travel Time (mins)
		on 8th Ave	Percent of OD Volume Using 8th Ave	Travel Time Change (%)	Change (mins)				
SF screenline south	Golden Gate Park	0.3%	5%		+3%	1293	67	27.10294118	27.84615385
Northeast	Outer Sunset	0.3%	2%		-10%	3062	67	48.70486111	43.98
Golden Gate Park	Richmond Subarea1	0.3%	4%		-11%	1515	66	16.03623188	14.20833333
Richmond Subarea3	South of Market	0.3%	4%		+1%	1793	66	39.40909091	39.85
Downtown	Richmond Subarea2	0.3%	2%		-18%	3368	66	39.93939394	32.68292683
Richmond Subarea4	Outer Sunset	0.3%	4%		-9%	1773	65	29.5	26.87804878
Richmond Subarea2	Western Addition	0.3%	2%		-3%	4043	65	21.9084507	21.16197183
Golden Gate Park	Marina	0.3%	10%		-15%	648	64	29.86734694	25.27906977
Golden Gate Park	Downtown	0.3%	6%		-7%	1155	64	36.59677419	34.11971831
SF screenline south	SF screenline east	0.3%	0%		-16%	19116	64	29.56666667	24.83333333
Richmond Subarea1	Golden Gate Park	0.3%	6%		+1%	978	63	16.04929577	16.27464789
Richmond Subarea1	Mission	0.3%	6%		-9%	1083	63	44.02173913	39.8880597
Richmond Subarea1	Central	0.3%	9%		-3%	687	62	37.59615385	36.48717949
North Inner Sunset	Richmond Subarea4	0.3%	8%		-0%	823	62	22.41176471	22.3902439
Mission	SF screenline north	0.3%	4%		-19%	1416	62	37.20103093	30.17961165
North Inner Sunset	Presidio	0.3%	19%		+33%	319	61	26.87333333	35.77941176
SF screenline north	Mission	0.3%	5%		+3%	1299	61	40.32608696	41.53488372
Golden Gate Park	SF screenline south	0.3%	4%		-2%	1610	61	25.3313253	24.84782609
Richmond Subarea1	Ingleside	0.3%	2%		-5%	3323	60	34.33333333	32.64864865
Richmond Subarea4	North Inner Sunset	0.3%	6%		-4%	915	59	21.46031746	20.61764706
Western Addition	Richmond Subarea1	0.3%	1%		-12%	4931	59	28.63333333	25.14556962
Downtown	SF screenline south	0.3%	0%		-25%	23680	59	27.75	20.88636364
Downtown	Richmond Subarea1	0.3%	1%		-7%	3884	58	44.90350877	41.93478261
Western Addition	SF screenline south	0.3%	0%		-8%	11461	57	31.81746032	29.375
Richmond Subarea1	Western Addition	0.3%	1%		-4%	5011	55	28.39873418	27.30232558
Central	Richmond Subarea1	0.3%	7%		-10%	724	54	39.3	35.44736842
SF screenline south	Richmond Subarea2	0.3%	2%		-5%	2300	54	30.77272727	29.09677419
Buena Vista	Golden Gate Park	0.3%	5%		-7%	1079	53	22.34615385	20.72222222
Richmond Subarea1	South Inner Sunset	0.2%	7%		-12%	766	51	30.97619048	27.38888889
SF screenline east	SF screenline south	0.2%	0%		-34%	20120	51	19.14534884	12.72929936
Richmond Subarea1	Buena Vista	0.2%	9%		-9%	574	50	32.86956522	29.95588235
Richmond Subarea3	Western Addition	0.2%	1%		-10%	6455	50	18.95588235	17.02631579
Outer Sunset	Marina	0.2%	3%		-5%	1782	49	33.77173913	32.23043478
Presidio	Golden Gate Park	0.2%	17%		-5%	282	48	24.60909091	23.5
Richmond Subarea1	North Inner Sunset	0.2%	4%		-9%	1151	47	24.453125	22.34210526
South Inner Sunset	Richmond Subarea4	0.2%	9%		-0%	510	45	23.91538462	23.85135135
Golden Gate Park	Central	0.2%	6%		-2%	796	44	28.55	28.05555556
South Inner Sunset	Richmond Subarea1	0.2%	6%		-2%	758	44	29.70967742	29
Central	SF screenline north	0.2%	5%		-2%	942	43	31.58139535	30.88317757
Richmond Subarea4	SF screenline south	0.2%	2%		+6%	1934	43	33.64084507	35.59734513
Western Addition	South Central	0.2%	1%		-3%	4461	43	40.8902439	39.66129032
Golden Gate Park	North Inner Sunset	0.2%	3%		-4%	1606	42	17.1	16.41011236
SF screenline north	SF screenline south	0.2%	1%		+6%	7920	42	28.22173913	29.94099379
Northeast	Downtown	0.2%	0%		+0%	44479	42	20.59090909	20.63157895
Central	Golden Gate Park	0.2%	7%		+5%	622	41	30	31.43333333
Marina	Outer Sunset	0.2%	2%		-4%	1949	41	39.31034483	37.70430108
Ingleside	Richmond Subarea2	0.2%	2%		+6%	2223	41	31.68055556	33.46296296

Origin Zone Name	Destination Zone Name on 8th Ave	% of Total Volume		Travel Time		Fall 2019 Total Volume	Fall 2019 Volume Via 8th Ave	Fall 2019 Median Travel Time (mins)	Fall 2021 Median Travel Time (mins)	
		Percent of OD Volume Using 8th Ave	Travel Time Change (%)	Change (mins)						
South Bayshore	SF screenline north	0.2%	6%		-20%	-9.70	655	39	48.41044776	38.71111111
SF screenline south	Presidio	0.2%	3%		-8%	-3.13	1239	39	38.31188119	35.17857143
Northeast	Richmond Subarea3	0.2%	2%		-11%	-3.60	2432	39	32.46825397	28.87234043
Western Addition	Ingleside	0.2%	1%		-5%	-1.86	5022	39	38.78787879	36.92465753
SF screenline south	Northeast	0.2%	0%		-20%	-7.79	11551	39	38.12318841	30.33544304
SF screenline north	South Inner Sunset	0.2%	8%		+1%	+0.41	483	38	27.86507937	28.27777778
SF screenline east	SF screenline north	0.2%	5%		-31%	-14.78	756	38	47.46153846	32.67777778
South Inner Sunset	Western Addition	0.2%	2%		-16%	-4.74	2103	38	29.31538462	24.57692308
Richmond Subarea2	Ingleside	0.2%	2%		-7%	-2.23	2266	38	32.99056604	30.75925926
South of Market	Golden Gate Park	0.2%	8%		+13%	+5.03	492	37	38.72222222	43.75
South Inner Sunset	Richmond Subarea2	0.2%	7%		-6%	-1.45	538	37	22.98333333	21.53597122
Golden Gate Park	Outer Sunset	0.2%	1%		-1%	-0.25	3344	37	17.29761905	17.05140187
Ingleside	Richmond Subarea4	0.2%	3%		-10%	-3.74	1309	36	39.16666667	35.42783505
Richmond Subarea3	Richmond Subarea3	0.2%	1%		-10%	-1.32	4436	36	13.77272727	12.45283019
Central	Western Addition	0.2%	1%		-8%	-2.05	5215	36	24.58108108	22.53333333
Northeast	SF screenline south	0.2%	0%		-16%	-6.25	11606	36	38.2	31.94776119
SF screenline south	South of Market	0.2%	0%		-15%	-3.50	27725	36	22.61290323	19.1125
North Inner Sunset	Richmond Subarea1	0.2%	3%		-7%	-1.64	1126	35	23.51298701	21.87362637
SF screenline north	South of Market	0.2%	1%		-4%	-1.79	3901	35	44.29310345	42.5
Richmond Subarea2	South Inner Sunset	0.2%	6%		-3%	-0.83	577	34	26.42307692	25.5952381
North Inner Sunset	Downtown	0.2%	1%		-8%	-2.80	2760	34	34.51960784	31.72413793
Buena Vista	Outer Sunset	0.2%	1%		-15%	-4.54	3695	34	30.59090909	26.0505618
South of Market	SF screenline north	0.2%	1%		-18%	-7.41	3965	34	40.13768116	32.73076923
SF screenline east	Golden Gate Park	0.2%	6%		-12%	-4.05	558	33	34.86734694	30.82142857
Buena Vista	Richmond Subarea1	0.2%	5%		-13%	-3.96	620	33	31.40322581	27.44262295
South Central	Richmond Subarea4	0.2%	4%		-12%	-4.43	852	33	44.2	33.89215686
Richmond Subarea2	Downtown	0.2%	1%		-12%	-4.43	3336	33	38.32608696	33.89215686
Golden Gate Park	Presidio	0.2%	10%		-11%	-2.54	309	32	23.56666667	21.02777778
Golden Gate Park	Ingleside	0.2%	2%		-7%	-1.92	1327	32	27.96296296	26.04166667
Northeast	Richmond Subarea2	0.2%	2%		-20%	-7.71	1757	32	38.69642857	30.98979592
Richmond Subarea3	Downtown	0.1%	1%		-7%	-2.34	4074	31	33.23170732	30.89370079
SF screenline north	Downtown	0.1%	0%		-6%	-1.98	6506	31	34.44736842	32.46551724
Richmond Subarea3	Bernal Heights	0.1%	17%		-18%	-7.07	177	30	42.14893617	32.08461538
Golden Gate Park	Mission	0.1%	5%		-14%	-5.55	4646	30	39.05	33.5
SF screenline south	Marina	0.1%	1%		-29%	-5.39	27410	29	18.86486486	13.47777778
South of Market	SF screenline south	0.1%	0%		-0%	-0.07	858	28	48.17241379	48.10606061
Richmond Subarea4	South Central	0.1%	3%		-10%	-2.80	3592	28	28.57058824	25.77433628
SF screenline south	Richmond Subarea1	0.1%	1%		-7%	-2.34	126	27	43.11751152	35.54166667
Richmond Subarea2	Bernal Heights	0.1%	21%		+7%	+2.54	769	27	35.54166667	38.08536585
Golden Gate Park	South of Market	0.1%	4%		-9%	-3.41	1235	27	39.38235294	35.96969697
North Inner Sunset	Northeast	0.1%	2%		-5%	-1.88	2253	27	34.5212766	32.6443299
Richmond Subarea3	Northeast	0.1%	1%		-0%	-0.08	256	26	46.2184466	18.59589041
SF screenline north	Bernal Heights	0.1%	10%		+3%	+0.89	1212	26	29.77272727	30.65789474
North Inner Sunset	Golden Gate Park	0.1%	2%		-2%	-0.26	2064	26	17.23684211	16.97674419
Ingleside	SF screenline north	0.1%	1%		-0%	-0.08	2166	26	23.83823529	
Outer Sunset	Golden Gate Park	0.1%	1%		-0%	-0.08	221	25		
Golden Gate Park	Richmond LandsEnd	0.1%	11%		-0%	-0.08				

Origin Zone Name	Destination Zone Name on 8th Ave	% of Total Volume		Travel Time		Fall 2019 Total Volume	Fall 2019 Volume Via 8th Ave	Fall 2019 Median Travel Time (mins)	Fall 2021 Median Travel Time (mins)
		Percent of OD Volume Using 8th Ave	Travel Time Change (%)	Change (mins)					
Marina	North Inner Sunset	0.1%	3%	 +20%	+6.79	946	25	33.47435897	40.26666667
Outer Sunset	SF screenline south	0.1%	0%	 -4%	-0.74	17977	25	17.65909091	16.91666667
SF screenline east	Presidio	0.1%	4%	 -10%	-3.88	560	24	39.23255814	35.34962406
SF screenline north	South Bayshore	0.1%	4%	 -0%	-0.02	608	24	48.86507937	48.84983498
Richmond Subarea4	South Inner Sunset	0.1%	4%	 +8%	+2.21	621	24	28.72222222	30.93076923
Western Addition	South Bayshore	0.1%	1%	 -7%	-2.60	2558	24	37.38	34.77777778
Ingleside	Richmond Subarea1	0.1%	1%	 -15%	-5.31	3163	24	35.68518519	30.37272727
Richmond Subarea4	Ingleside	0.1%	2%	 +2%	+0.78	1217	23	36.78767123	37.56976744
South Central	Golden Gate Park	0.1%	5%	 -13%	-5.21	424	22	38.76666667	33.55813953
Buena Vista	Northeast	0.1%	1%	 -19%	-6.48	1858	22	34.86842105	28.38732394
Richmond Subarea4	Richmond Subarea3	0.1%	1%	 -12%	-1.74	3541	22	14.00632911	12.26767677
Richmond Subarea2	Richmond Subarea3	0.1%	1%	 -10%	-1.50	4235	22	14.6547619	13.15789474
SF screenline east	Downtown	0.1%	0%	 -26%	-5.58	26130	22	21.14285714	15.56603774
Western Addition	Western Addition	0.1%	0%	 -6%	-0.89	27090	22	15.38888889	14.5
Golden Gate Park	SF screenline east	0.1%	3%	 +1%	+0.57	617	21	38.46153846	39.03333333
Downtown	Presidio	0.1%	1%	 -23%	-9.15	1518	21	40.15217391	31
Richmond Subarea3	Richmond Subarea1	0.1%	1%	 -7%	-1.30	3396	21	18.05670103	16.76086957
Downtown	Marina	0.1%	0%	 -24%	-6.99	10748	21	28.75490196	21.76530612
Mission	SF screenline south	0.1%	0%	 -13%	-2.34	13307	21	18.63580247	16.3
Mission	Golden Gate Park	0.1%	4%	 -8%	-2.84	486	20	33.87755102	31.036
Ingleside	Golden Gate Park	0.1%	2%	 -2%	-0.43	984	20	27.78571429	27.35185185
South Bayshore	Western Addition	0.1%	1%	 -18%	-7.53	2484	20	41.04166667	33.51449275
Richmond Subarea3	Richmond Subarea2	0.1%	0%	 -13%	-1.99	4128	20	15.1097561	13.11956522
Outer Sunset	North Inner Sunset	0.1%	0%	 -11%	-2.03	6974	20	18.39041096	16.36075949
Downtown	Western Addition	0.1%	0%	 -19%	-4.68	23356	20	24.5	19.81884058
Downtown	South of Market	0.1%	0%	 -16%	-3.65	44813	20	22.18181818	18.52739726
Mission	Richmond LandsEnd	0.1%	16%			120	19		
South Inner Sunset	Golden Gate Park	0.1%	3%	 -6%	-1.25	555	19	22.1509434	20.9057971
SF screenline south	Richmond Subarea4	0.1%	1%	 -10%	-3.40	1889	19	35.23626374	31.83333333
SF screenline north	Western Addition	0.1%	1%	 -7%	-1.68	3367	19	22.85714286	21.17532468
Richmond Subarea1	Downtown	0.1%	0%	 -6%	-2.74	4037	19	42.86956522	40.12666667
SF screenline east	Western Addition	0.1%	0%	 -19%	-5.66	6857	19	29.0212766	23.36507937
South of Market	Mission	0.1%	0%	 -18%	-3.95	18173	19	22.00819672	18.0625
South of Market	Downtown	0.1%	0%	 -12%	-2.27	45557	19	19.28378378	17.01612903
Downtown	Downtown	0.1%	0%	 -12%	-2.09	77650	19	17.44505495	15.35106383
Bernal Heights	SF screenline north	0.1%	6%	 -9%	-3.69	282	18	40.13953488	36.45238095
Northeast	Presidio	0.1%	1%	 -15%	-4.38	2134	18	29.36567164	24.9875
SF screenline south	Buena Vista	0.1%	1%	 -6%	-1.63	3105	18	26.69354839	25.06
Richmond Subarea1	SF screenline south	0.1%	1%	 -4%	-1.10	3415	18	27.42063492	26.32352941
SF screenline south	Mission	0.1%	0%	 -17%	-3.47	13090	18	20.34615385	16.87179487
South of Market	South of Market	0.1%	0%	 -10%	-1.69	57843	18	17.5875	15.89759036
Presidio	North Inner Sunset	0.1%	5%	 -0%	-0.01	348	17	31.25925926	31.25263158
Richmond Subarea2	Richmond Subarea2	0.1%	1%	 -9%	-1.25	3378	17	13.14814815	11.9
Buena Vista	South Central	0.1%	1%	 -9%	-3.19	1292	16	34.34482759	31.15714286
South of Market	Outer Sunset	0.1%	0%	 -22%	-10.32	3592	16	47.44545455	37.12857143
Outer Sunset	South of Market	0.1%	0%	-6%	-2.66	3778	16	42.30952381	39.65217391
Ingleside	Downtown	0.1%	0%	-14%	-5.93	4025	16	43.34615385	37.41836735

Origin Zone Name	Destination Zone Name on 8th Ave	% of Total Volume		Percent of OD Volume		Travel Time		Fall 2019 Total Volume	Fall 2019 Volume Via 8th Ave	Fall 2019 Median Travel Time (mins)	Fall 2021 Median Travel Time (mins)
		Using 8th Ave	Using 8th Ave	Travel Time Change (%)	Change (mins)						
South of Market	Central	0.1%	0%		-17%	-5.54	5124	16	31.875	26.33333333	
Downtown	SF screenline east	0.1%	0%		-9%	-1.58	22529	16	18.44029851	16.8625	
Richmond LandsEnd	Golden Gate Park	0.1%	7%		7%		203	15	20.77142857		
North Inner Sunset	Marina	0.1%	2%		-7%	-2.08	892	15	30.57792208	28.5	
Central	Richmond Subarea4	0.1%	1%		+9%	+2.34	1038	15	26.34962406	28.69387755	
SF screenline north	Richmond Subarea3	0.1%	1%		-13%	-1.83	1068	15	14.33333333	12.5	
SF screenline north	Ingleside	0.1%	1%		+3%	+0.94	1731	15	33.93518519	34.87096774	
North Inner Sunset	South of Market	0.1%	1%		-6%	-2.41	2572	15	39.74193548	37.33185841	
Richmond Subarea1	Richmond Subarea3	0.1%	0%		-4%	-0.84	3070	15	19.15853659	18.31609195	
Richmond Subarea3	Richmond Subarea4	0.1%	0%		-16%	-2.52	3104	15	15.40225564	12.88095238	
Mission	Outer Sunset	0.1%	0%		-20%	-8.41	3171	15	42.58474576	34.17692308	
Richmond Subarea2	Outer Sunset	0.1%	0%		-10%	-2.36	3457	15	23.3	20.9375	
Ingleside	SF screenline east	0.1%	0%		-14%	-6.29	3797	15	43.42424242	37.13218391	
Mission	Buena Vista	0.1%	0%		-11%	-2.55	5111	15	22.52777778	19.97297297	
Western Addition	Northeast	0.1%	0%		-12%	-3.05	9868	15	24.93548387	21.88983051	
Marina	Western Addition	0.1%	0%		-13%	-2.48	10729	15	19.67105263	17.18686869	
SF screenline south	Outer Sunset	0.1%	0%		-13%	-2.82	17429	15	21.1741573	18.35714286	
Richmond Subarea2	Northeast	0.1%	1%		-7%	-2.34	1778	14	33.7	31.36363636	
Outer Sunset	South Bayshore	0.1%	1%		-3%	-1.47	2204	14	42.33823529	40.86363636	
Buena Vista	SF screenline south	0.1%	0%		-3%	-0.86	3194	14	24.71917808	23.86363636	
Downtown	Ingleside	0.1%	0%		-26%	-11.66	4155	14	45.18627451	33.52941176	
North Inner Sunset	SF screenline south	0.1%	0%		-8%	-2.03	4512	14	26.28205128	24.25471698	
Western Addition	Central	0.1%	0%		-1%	-0.20	5063	14	25.68309859	25.48113208	
Northeast	Mission	0.1%	0%		-9%	-3.31	5307	14	38.14516129	34.83333333	
Northeast	Western Addition	0.1%	0%		-15%	-4.18	9874	14	28	23.8164557	
Western Addition	Downtown	0.1%	0%		-11%	-2.47	24168	14	21.56578947	19.1	
Golden Gate Park	Bernal Heights	0.1%	11%		11%		121	13	35.54123711		
Mission	Presidio	0.1%	3%		+8%	+3.56	433	13	42.8125	46.375	
South Bayshore	Richmond Subarea4	0.1%	3%		-20%	-8.80	481	13	43.31651376	34.51538462	
SF screenline north	SF screenline east	0.1%	2%		-1%	-0.60	701	13	49.14605263	48.54615385	
Western Addition	Presidio	0.1%	1%		+4%	+0.85	1441	13	23.26344086	24.1119403	
SF screenline east	Buena Vista	0.1%	1%		-16%	-4.60	1937	13	28.86363636	24.26744186	
Ingleside	Northeast	0.1%	0%		-9%	-4.41	2837	13	48.75684932	44.34313725	
Richmond Subarea1	Outer Sunset	0.1%	0%		+9%	+1.92	4790	13	20.45890411	22.37640449	
Richmond Subarea2	Richmond Subarea1	0.1%	0%		-6%	-0.91	4882	13	14.4223301	13.51030928	
SF screenline north	Marina	0.1%	0%		-9%	-1.31	4907	13	14.01086957	12.69847328	
Mission	SF screenline east	0.1%	0%		-11%	-3.22	7084	13	28.14935065	24.93209877	
South of Market	South Central	0.1%	0%		-20%	-5.84	7867	13	28.92307692	23.08666667	
Ingleside	SF screenline south	0.1%	0%		-16%	-1.84	32166	13	11.375	9.538461538	
Outer Sunset	Outer Sunset	0.1%	0%		-12%	-1.60	47035	13	13.88095238	12.28217822	
Ingleside	Ingleside	0.1%	0%		-9%	-1.38	57667	13	15.57142857	14.18888889	
Richmond LandsEnd	South Bayshore	0.1%	18%		18%		65	12			
Richmond LandsEnd	SF screenline east	0.1%	7%		7%		162	12	49.20728643		
Presidio	Ingleside	0.1%	2%		+2%	+0.94	585	12	40.58108108	41.52469136	
SF screenline east	Richmond Subarea4	0.1%	1%		-26%	-9.12	1127	12	34.54	25.41764706	
Marina	Ingleside	0.1%	1%		-10%	-4.77	1511	12	48.25757576	43.4826087	
Marina	Central	0.1%	1%		-11%	-3.93	1561	12	36.72727273	32.7972973	

Origin Zone Name	Destination Zone Name	% of Total Volume		Travel Time		Fall 2019 Total Volume	Fall 2019 Volume Via 8th Ave	Fall 2019 Median Travel Time (mins)	Fall 2021 Median Travel Time (mins)
		on 8th Ave	Percent of OD Volume Using 8th Ave	Travel Time Change (%)	Change (mins)				
Marina	Richmond Subarea3	0.1%	1%	-4%	-0.88	2015	12	22.70967742	21.83009709
SF screenline north	Outer Sunset	0.1%	1%	+1%	+0.26	2034	12	23.44354839	23.70652174
SF screenline east	North Inner Sunset	0.1%	1%	-14%	-5.26	2037	12	37.89784946	32.63846154
South Bayshore	Outer Sunset	0.1%	1%	-11%	-4.43	2345	12	40.89726027	36.46774194
Mission	Marina	0.1%	0%	-3%	-0.89	3271	12	31.28125	30.3961039
Marina	SF screenline south	0.1%	0%	-10%	-3.87	4695	12	39.89622642	36.02857143
Mission	Ingleside	0.1%	0%	-20%	-6.56	5038	12	33.16037736	26.6
SF screenline east	South of Market	0.1%	0%	-6%	-1.27	19636	12	19.98571429	18.71212121
South of Market	SF screenline east	0.1%	0%	+5%	+0.70	25358	12	14.69047619	15.39333333
Mission	Mission	0.1%	0%	-9%	-1.36	39570	12	15.96428571	14.60638298
South of Market	Richmond LandsEnd	0.1%	9%			125	11	49.20967742	
Buena Vista	Presidio	0.1%	2%	+2%	+0.59	472	11	27.51369863	28.10784314
Presidio	Mission	0.1%	2%	+12%	+4.95	481	11	41.14	46.09090909
Presidio	Central	0.1%	2%	-14%	-5.72	565	11	41.71428571	35.99056604
SF screenline north	Richmond Subarea2	0.1%	1%	-29%	-3.90	1056	11	13.52654867	9.630653266
Northeast	North Inner Sunset	0.1%	1%	+2%	+0.86	1070	11	43.55882353	44.42156863
South Inner Sunset	Downtown	0.1%	1%	-20%	-7.62	1389	11	37.48113208	29.86046512
Mission	North Inner Sunset	0.1%	1%	-10%	-3.51	1858	11	34.63793103	31.12903226
Western Addition	South Inner Sunset	0.1%	1%	-5%	-1.62	1987	11	30.98684211	29.36666667
Outer Sunset	Richmond Subarea2	0.1%	0%	-7%	-1.63	2737	11	23.08974359	21.45833333
Northeast	Ingleside	0.1%	0%	-8%	-4.08	2891	11	48.87066246	44.78985507
Northeast	South Central	0.1%	0%	-14%	-7.05	5262	11	48.66094033	41.61428571
Richmond Subarea4	Western Addition	0.1%	0%	-14%	-2.15	5902	11	15.39333333	13.24157303
Buena Vista	Downtown	0.1%	0%	+2%	+0.46	6288	11	25.48305085	25.94285714
Western Addition	SF screenline east	0.1%	0%	-17%	-6.23	6372	11	36.55970149	30.32716049
South Inner Sunset	Presidio	0.0%	4%	+7%	+2.26	261	10	30.9084507	33.16666667
SF screenline north	South Central	0.0%	1%	-1%	-0.54	696	10	43.22	42.67924528
Richmond Subarea3	Marina	0.0%	1%	-12%	-2.77	1819	10	23.07142857	20.30327869
Northeast	Richmond Subarea1	0.0%	0%	-16%	-7.15	2074	10	43.77118644	36.625
Marina	SF screenline east	0.0%	0%	-13%	-4.88	2832	10	37.64084507	32.76190476
South Inner Sunset	North Inner Sunset	0.0%	0%	-11%	-1.59	3341	10	15.1557377	13.56315789
Outer Sunset	Mission	0.0%	0%	-8%	-3.12	3425	10	38.09016393	34.97457627
Outer Sunset	Buena Vista	0.0%	0%	-6%	-1.67	3465	10	28.97222222	27.29746835
Outer Sunset	Richmond Subarea1	0.0%	0%	-8%	-1.47	4976	10	18.875	17.40196078
SF screenline north	Northeast	0.0%	0%	-9%	-2.44	5706	10	26.92424242	24.48
Richmond Subarea1	Richmond Subarea1	0.0%	0%	-4%	-0.61	7376	10	13.60204082	12.9950495
Mission	Western Addition	0.0%	0%	-18%	-5.03	8462	10	28.2037037	23.17142857
Northeast	Marina	0.0%	0%	-9%	-1.72	13591	10	19.27941176	17.55813953
South Bayshore	SF screenline south	0.0%	0%	-9%	-1.18	15344	10	13.49056604	12.30582524
Richmond LandsEnd	Mission	0.0%	8%			116	9	46.41860465	
Downtown	Richmond LandsEnd	0.0%	2%			366	9	48.53921569	
South Bayshore	Presidio	0.0%	6%			162	9	49.26237624	
Golden Gate Park	South Central	0.0%	1%	+11%	+4.12	615	9	37.21186441	41.33333333
Outer Sunset	Presidio	0.0%	1%	-11%	-3.67	714	9	31.97619048	28.30582524
South Central	SF screenline north	0.0%	1%	-2%	-0.67	845	9	42.5	41.83333333
Richmond Subarea4	Central	0.0%	1%	+7%	+2.01	946	9	29.30392157	31.31481481
Marina	Richmond Subarea1	0.0%	1%	-16%	-5.02	1466	9	30.93333333	25.91666667

Origin Zone Name	Destination Zone Name	% of Total Volume		Travel Time		Fall 2019 Total Volume	Fall 2019 Volume Via 8th Ave	Fall 2019 Median Travel Time (mins)	Fall 2021 Median Travel Time (mins)
		on 8th Ave	Using 8th Ave	Travel Time Change (%)	Change (mins)				
Central	Marina	0.0%	1%	+0%	+0.04	1532	9	32.22368421	32.26744186
North Inner Sunset	SF screenline east	0.0%	0%	-1%	-0.54	1922	9	42.29746835	41.75490196
Richmond Subarea1	Northeast	0.0%	0%	-12%	-5.02	2189	9	43.01219512	37.99333333
South of Market	North Inner Sunset	0.0%	0%	-9%	-3.48	2544	9	39.671875	36.19333333
SF screenline east	Ingleside	0.0%	0%	-31%	-10.88	3858	9	35.38235294	24.5
Ingleside	North Inner Sunset	0.0%	0%	+6%	+1.44	4066	9	22.79761905	24.23611111
Central	Downtown	0.0%	0%	-1%	-0.44	5262	9	30.70930233	30.26842105
Mission	Northeast	0.0%	0%	-16%	-5.49	5394	9	33.36363636	27.86986301
Mission	South Bayshore	0.0%	0%	-12%	-3.05	8398	9	25.48113208	22.42647059
Northeast	SF screenline east	0.0%	0%	-17%	-4.86	10398	9	27.91071429	23.05405405
Marina	Downtown	0.0%	0%	-5%	-1.49	10730	9	27.81666667	26.32608696
SF screenline east	Northeast	0.0%	0%	-21%	-4.84	11643	9	23.53225806	18.68823529
Mission	Downtown	0.0%	0%	-8%	-1.92	15895	9	24.25925926	22.33544304
SF screenline south	Ingleside	0.0%	0%	-20%	-2.39	31662	9	11.85555556	9.468992248
Northeast	Richmond LandsEnd	0.0%	3%			233	8	37.42792793	
Bernal Heights	Presidio	0.0%	5%			158	8		
Presidio	South Inner Sunset	0.0%	3%			232	8	33.92857143	
South Inner Sunset	Northeast	0.0%	1%	-13%	-6.07	905	8	47.88461538	41.8125
Downtown	South Inner Sunset	0.0%	1%	-13%	-5.27	1339	8	39.67391304	34.4010989
Richmond Subarea3	SF screenline north	0.0%	1%	-13%	-1.47	1429	8	11.06349206	9.594339623
Presidio	Northeast	0.0%	0%	-6%	-1.89	2133	8	31.2	29.30882353
Outer Sunset	SF screenline north	0.0%	0%	-14%	-3.33	2152	8	24.06962025	20.73611111
Buena Vista	North Inner Sunset	0.0%	0%	-14%	-2.55	3677	8	17.9875	15.43641618
SF screenline south	North Inner Sunset	0.0%	0%	-13%	-3.09	4443	8	23.70238095	20.61111111
Marina	South of Market	0.0%	0%	-5%	-2.05	5448	8	37.82692308	35.77692308
Ingleside	South of Market	0.0%	0%	-13%	-4.67	5494	8	35.56521739	30.89622642
Northeast	South of Market	0.0%	0%	-11%	-3.40	15787	8	30.29245283	26.8968254
Richmond LandsEnd	South of Market	0.0%	6%			109	7	48.93074581	
Richmond LandsEnd	Central	0.0%	5%			128	7	45.9	
Bernal Heights	Richmond Subarea2	0.0%	6%			108	7		42.04444444
Central	Presidio	0.0%	1%	-23%	-9.47	594	7	40.66666667	31.19298246
South of Market	Presidio	0.0%	1%	+6%	+2.41	712	7	41.5	43.91176471
Richmond Subarea1	Presidio	0.0%	1%	+10%	+2.06	867	7	20.73529412	22.79268293
Presidio	SF screenline south	0.0%	1%	+0%	+0.14	1195	7	37.79824561	37.94186047
Richmond Subarea2	Marina	0.0%	0%	-13%	-3.09	1525	7	22.98529412	19.89240506
Buena Vista	Marina	0.0%	0%	+2%	+0.39	1692	7	25.12195122	25.51470588
North Inner Sunset	Mission	0.0%	0%	-22%	-6.64	1758	7	30.77906977	24.14084507
Buena Vista	SF screenline east	0.0%	0%	-6%	-1.90	1958	7	33.09090909	31.19387755
North Inner Sunset	Ingleside	0.0%	0%	-0%	-0.12	3765	7	25.68571429	25.56451613
South Bayshore	Downtown	0.0%	0%	-21%	-8.96	6140	7	41.875	32.91818182
SF screenline south	Central	0.0%	0%	-10%	-1.80	6354	7	17.73076923	15.92696629
North Inner Sunset	North Inner Sunset	0.0%	0%	-2%	-0.22	6518	7	14.49038462	14.27142857
Downtown	Buena Vista	0.0%	0%	-10%	-2.57	6629	7	26.19491525	23.625
Buena Vista	Western Addition	0.0%	0%	-2%	-0.28	6878	7	16.8875	16.60344828
SF screenline east	Mission	0.0%	0%	-24%	-5.79	7225	7	24.12222222	18.33333333
Western Addition	Buena Vista	0.0%	0%	-2%	-0.36	7399	7	17.85135135	17.48734177
South Central	Downtown	0.0%	0%	-20%	-8.41	8567	7	42.57142857	34.16037736

Origin Zone Name	Destination Zone Name on 8th Ave	% of Total Volume		Percent of OD Volume		Travel Time		Fall 2019 Total Volume	Fall 2019 Volume Via 8th Ave	Fall 2019 Median Travel Time (mins)	Fall 2021 Median Travel Time (mins)
		Using 8th Ave	Using 8th Ave	Travel Time Change (%)	Change (mins)						
Western Addition	Mission	0.0%	0%	-8%	-2.05	8935	7	25.55	23.5		
South of Market	Western Addition	0.0%	0%	-15%	-4.96	9116	7	32.97457627	28.015625		
Western Addition	Marina	0.0%	0%	-5%	-0.98	10546	7	18.41891892	17.43684211		
Outer Sunset	South Inner Sunset	0.0%	0%	-15%	-2.65	11115	7	17.52777778	14.8814433		
Downtown	Mission	0.0%	0%	-9%	-2.23	16739	7	25.35714286	23.12295082		
Outer Sunset	Ingleside	0.0%	0%	-13%	-2.73	22417	7	21.00666667	18.28021978		
North Inner Sunset	Richmond LandsEnd	0.0%	5%			125	6				
Presidio	South Bayshore	0.0%	5%	+0%	+0.14	119	6	49.18421053	49.32352941		
Bernal Heights	Richmond Subarea1	0.0%	3%			190	6	45.51408451			
Golden Gate Park	South Bayshore	0.0%	2%	-6%	-2.30	247	6	41.5	39.19852941		
South Bayshore	Golden Gate Park	0.0%	2%	-7%	-2.80	274	6	37.51492537	34.71804511		
Presidio	Buena Vista	0.0%	1%	+25%	+6.95	483	6	26.66666667	33.62068966		
South Inner Sunset	Marina	0.0%	1%	-5%	-1.87	876	6	34.79090909	32.92045455		
Richmond Subarea1	SF screenline north	0.0%	0%	-13%	-1.80	1280	6	14.17326733	12.37790698		
Marina	Richmond Subarea2	0.0%	0%	-3%	-0.61	1498	6	21.85555556	21.24683544		
Richmond Subarea1	Richmond Subarea4	0.0%	0%	-12%	-2.75	1608	6	22.55172414	19.8030303		
Central	North Inner Sunset	0.0%	0%	-1%	-0.31	1680	6	21.77692308	21.46590909		
Richmond Subarea2	Richmond Subarea4	0.0%	0%	-11%	-1.82	1700	6	16.41666667	14.59322034		
Central	Northeast	0.0%	0%	-10%	-3.87	1772	6	40.25641026	36.38888889		
SF screenline east	Marina	0.0%	0%	-25%	-8.27	3138	6	32.47894737	24.21084337		
Richmond Subarea4	Downtown	0.0%	0%	-1%	-0.20	3662	6	27.99152542	27.78888889		
South of Market	Buena Vista	0.0%	0%	-17%	-5.39	3688	6	30.85849057	25.47101449		
South Central	SF screenline east	0.0%	0%	-11%	-4.09	3772	6	35.80588235	31.71428571		
South Bayshore	Ingleside	0.0%	0%	-12%	-3.54	5197	6	29.14912281	25.61392405		
South of Market	Marina	0.0%	0%	-19%	-6.75	5370	6	36.13636364	29.38888889		
South Central	Northeast	0.0%	0%	-15%	-7.22	5634	6	48.7444062	41.52380952		
South Bayshore	SF screenline east	0.0%	0%	-14%	-4.99	5991	6	34.65384615	29.65909091		
Mission	Bernal Heights	0.0%	0%	-5%	-0.91	6716	6	18.39873418	17.48701299		
Central	SF screenline south	0.0%	0%	-14%	-2.28	6980	6	16.38607595	14.10377358		
South Central	South Bayshore	0.0%	0%	-9%	-1.76	12417	6	18.59375	16.83802817		
Mission	South of Market	0.0%	0%	-18%	-3.89	18567	6	22.06451613	18.17647059		
Richmond LandsEnd	Buena Vista	0.0%	6%			77	5		36.5		
Western Addition	Richmond LandsEnd	0.0%	1%			409	5	31.76666667			
Presidio	South Central	0.0%	3%			192	5	49.00578035			
Presidio	Outer Sunset	0.0%	1%	+2%	+0.50	619	5	30.10344828	30.59859155		
Golden Gate Park	South Inner Sunset	0.0%	1%	-7%	-1.53	645	5	20.48148148	18.95588235		
South Inner Sunset	SF screenline north	0.0%	1%	-10%	-2.50	684	5	25.2654321	22.76666667		
Presidio	Western Addition	0.0%	0%	-15%	-3.78	1405	5	24.81481481	21.03571429		
Presidio	Downtown	0.0%	0%	-10%	-3.98	1498	5	40.82631579	36.84246575		
Richmond Subarea4	Richmond Subarea1	0.0%	0%	-2%	-0.39	1759	5	22.48863636	22.1036036		
Northeast	Central	0.0%	0%	-9%	-4.04	1937	5	42.61538462	38.57228916		
SF screenline north	Presidio	0.0%	0%	-15%	-1.64	2555	5	10.83333333	9.194214876		
SF screenline east	South Central	0.0%	0%	-15%	-4.21	3464	5	27.82989691	23.62380952		
North Inner Sunset	Buena Vista	0.0%	0%	-4%	-0.64	3767	5	17.13709677	16.5		
Richmond Subarea1	Richmond Subarea2	0.0%	0%	-15%	-2.31	4542	5	15.57865169	13.27083333		
South of Market	Ingleside	0.0%	0%	-18%	-6.27	5145	5	34.05319149	27.77868852		
Buena Vista	Buena Vista	0.0%	0%	-11%	-1.68	7175	5	15.32352941	13.64393939		

Origin Zone Name	Destination Zone Name on 8th Ave	% of Total Volume		Travel Time		Fall 2019 Total Volume	Fall 2019 Volume Via 8th Ave	Fall 2019 Median Travel Time (mins)	Fall 2021 Median Travel Time (mins)	
		Percent of OD Volume Using 8th Ave	Travel Time Change (%)	Change (mins)						
North Inner Sunset	Outer Sunset	0.0%	0%		-18%	-3.74	7404	5	20.51333333	16.77058824
Mission	South Central	0.0%	0%		-15%	-4.08	10312	5	28.00819672	23.92857143
South Bayshore	South of Market	0.0%	0%		-21%	-5.68	10595	5	26.83333333	21.15217391
South Inner Sunset	Outer Sunset	0.0%	0%		-12%	-2.23	11448	5	18.01136364	15.78440367
Marina	Northeast	0.0%	0%		-15%	-3.20	13495	5	21.04411765	17.84328358
South Inner Sunset	Ingleside	0.0%	0%		-6%	-1.13	14492	5	18.1627907	17.03246753
Ingleside	South Central	0.0%	0%		-9%	-1.99	21117	5	22.28125	20.29268293
Ingleside	Outer Sunset	0.0%	0%		-13%	-2.70	22123	5	20.93283582	18.23493976
South Bayshore	South Bayshore	0.0%	0%		-11%	-1.60	24947	5	14.95	13.35263158
South Central	SF screenline south	0.0%	0%		+3%	+0.23	37217	5	6.81372549	7.045454545
South Central	South Central	0.0%	0%		-11%	-1.64	48751	5	14.97826087	13.34042553
Buena Vista	Richmond LandsEnd	0.0%	4%				95	4		
Central	Richmond LandsEnd	0.0%	3%				130	4		
Richmond LandsEnd	Richmond Subarea3	0.0%	2%		-23%	-6.52	196	4	28.57017544	22.04761905
Richmond Subarea3	Richmond LandsEnd	0.0%	2%				243	4	21.93442623	
Richmond LandsEnd	Ingleside	0.0%	1%				310	4	31.92222222	
Richmond LandsEnd	Outer Sunset	0.0%	1%		-13%	-3.26	625	4	25.4245283	22.16666667
Ingleside	Presidio	0.0%	1%		-10%	-4.53	541	4	44.39583333	39.86206897
Marina	South Inner Sunset	0.0%	1%		-0%	-0.17	715	4	35.90540541	35.7375
Buena Vista	Bernal Heights	0.0%	1%		+3%	+0.75	724	4	28.08730159	28.83333333
Presidio	Richmond Subarea1	0.0%	0%		-2%	-0.33	866	4	20.66455696	20.33486239
Presidio	Richmond Subarea4	0.0%	0%		-2%	-0.37	1223	4	16.9537037	16.58536585
Buena Vista	Richmond Subarea4	0.0%	0%		-4%	-0.78	1286	4	20.83846154	20.0625
Richmond Subarea1	Marina	0.0%	0%		+10%	+2.74	1318	4	27.23684211	29.97222222
North Inner Sunset	Central	0.0%	0%		-8%	-1.88	1614	4	22.84375	20.96551724
North Inner Sunset	South Central	0.0%	0%		-7%	-2.36	1637	4	34.06	31.6971831
SF screenline east	Outer Sunset	0.0%	0%		-20%	-8.62	1970	4	43.82258065	35.19892473
Richmond Subarea4	Richmond Subarea2	0.0%	0%		-16%	-3.02	2003	4	18.375	15.35217391
Bernal Heights	Downtown	0.0%	0%		-21%	-7.50	2102	4	35.98863636	28.48901099
Central	SF screenline east	0.0%	0%		-7%	-2.69	2308	4	37.62121212	34.93055556
Presidio	SF screenline north	0.0%	0%		-20%	-1.86	2823	4	9.418918919	7.555555556
Central	Outer Sunset	0.0%	0%		-18%	-5.57	2870	4	31.78846154	26.21568627
South Central	Central	0.0%	0%		-12%	-2.70	4841	4	22.04411765	19.34444444
SF screenline south	South Inner Sunset	0.0%	0%		-13%	-2.09	5056	4	16.54901961	14.45882353
Outer Sunset	South Central	0.0%	0%		+3%	+1.03	5121	4	33.03731343	34.06756757
Ingleside	Mission	0.0%	0%		-13%	-4.41	5126	4	33.44545455	29.03947368
South Inner Sunset	SF screenline south	0.0%	0%		-3%	-0.57	5341	4	17.5	16.93333333
Central	Ingleside	0.0%	0%		-5%	-1.30	5632	4	24.1031746	22.8
Western Addition	Richmond Subarea4	0.0%	0%		-11%	-1.78	5829	4	15.48901099	13.70879121
South Central	Ingleside	0.0%	0%		-5%	-0.99	21014	4	20.76666667	19.77631579
SF screenline south	South Central	0.0%	0%		-15%	-1.09	34910	4	7.40070922	6.312030075
Richmond LandsEnd	North Inner Sunset	0.0%	2%				126	3	30.13478261	
Richmond LandsEnd	Northeast	0.0%	2%		-8%	-3.40	170	3	43.36666667	39.96428571
Richmond LandsEnd	Western Addition	0.0%	1%		-3%	-0.90	318	3	34.91666667	34.01492537
Richmond LandsEnd	Downtown	0.0%	1%		-23%	-10.73	349	3	47.21666667	36.48601399
Richmond LandsEnd	SF screenline south	0.0%	0%		-2%	-0.53	839	3	28.4245283	27.89344262
Bernal Heights	Golden Gate Park	0.0%	3%				100	3		

Origin Zone Name	Destination Zone Name on 8th Ave	% of Total Volume		Travel Time		Fall 2019 Total Volume	Fall 2019 Volume Via 8th Ave	Fall 2019 Median Travel Time (mins)	Fall 2021 Median Travel Time (mins)
		Percent of OD Volume Using 8th Ave	Travel Time Change (%)	Change (mins)					
South Central	Presidio	0.0%	2%			192	3	48.93279173	
Richmond Subarea4	South Bayshore	0.0%	1%		+7%	490	3	40.4	43.05555556
Presidio	SF screenline east	0.0%	1%		+3%	501	3	45.51587302	46.72222222
South Bayshore	North Inner Sunset	0.0%	0%		-15%	659	3	39.8030303	33.82954545
Richmond Subarea4	SF screenline east	0.0%	0%		-18%	967	3	42.83333333	35.28313253
Richmond Subarea4	Mission	0.0%	0%		-5%	1060	3	36.51724138	34.80188679
Richmond Subarea2	SF screenline north	0.0%	0%		-21%	1252	3	11.58333333	9.159259259
Richmond Subarea4	Buena Vista	0.0%	0%		-8%	1530	3	19.92168675	18.41428571
South Central	North Inner Sunset	0.0%	0%		-10%	1698	3	31.7027027	28.68888889
Ingleside	Buena Vista	0.0%	0%		-9%	1801	3	34.425	31.36206897
Northeast	Buena Vista	0.0%	0%		-12%	1972	3	34.88709677	30.64
Downtown	Bernal Heights	0.0%	0%		-12%	2016	3	35.11016949	30.96835443
Outer Sunset	SF screenline east	0.0%	0%		-2%	2093	3	48.53646833	47.51333333
Central	South Bayshore	0.0%	0%		-5%	2378	3	29.7962963	28.22222222
Outer Sunset	Central	0.0%	0%		-10%	2695	3	29.80434783	26.93548387
Northeast	South Bayshore	0.0%	0%		-15%	3212	3	45.77906977	38.77777778
Marina	Presidio	0.0%	0%		-17%	3817	3	16.76829268	13.98101266
South Central	Outer Sunset	0.0%	0%		-12%	4863	3	35.07894737	30.95205479
Central	Buena Vista	0.0%	0%		-11%	5088	3	18.078125	16.12765957
Ingleside	South Bayshore	0.0%	0%		-10%	5303	3	30.00909091	27.07692308
Ingleside	Central	0.0%	0%		-4%	5589	3	23.98529412	23.00847458
Marina	SF screenline north	0.0%	0%		-22%	5678	3	13.94318182	10.86153846
Downtown	South Bayshore	0.0%	0%		-15%	5931	3	37.6875	31.97826087
Downtown	South Central	0.0%	0%		-13%	8538	3	37.77586207	32.88095238
South Inner Sunset	South Inner Sunset	0.0%	0%		-8%	8628	3	12.625	11.67592593
South Central	Mission	0.0%	0%		-7%	10273	3	27.54	25.67808219
SF screenline south	South Bayshore	0.0%	0%		-14%	15749	3	12.14646465	10.40163934
Central	Central	0.0%	0%		-7%	18554	3	14.23076923	13.29807692
South Inner Sunset	Richmond LandsEnd	0.0%	2%			121	2		
Richmond LandsEnd	South Inner Sunset	0.0%	2%		+26%	107	2	28.46551724	35.94210526
North Inner Sunset	Bernal Heights	0.0%	1%		-23%	349	2	38.61363636	29.89473684
Northeast	South Inner Sunset	0.0%	0%		-10%	785	2	46.47142857	41.86
Presidio	South of Market	0.0%	0%		+5%	791	2	46.14	48.61580882
Richmond Subarea2	Presidio	0.0%	0%		-6%	845	2	18.225	17.17045455
Bernal Heights	Northeast	0.0%	0%		-11%	924	2	44.1	39.04736842
Presidio	Richmond Subarea3	0.0%	0%		-19%	967	2	20.72641509	16.75
South Bayshore	Buena Vista	0.0%	0%		-2%	992	2	35.87634409	35.3203125
Bernal Heights	SF screenline east	0.0%	0%		-15%	1176	2	36.60958904	31.16304348
Bernal Heights	Western Addition	0.0%	0%		-12%	1413	2	32.73076923	28.91538462
South of Market	Richmond Subarea4	0.0%	0%		-22%	1529	2	38.05555556	29.51282051
Marina	Buena Vista	0.0%	0%		-9%	1769	2	26.89772727	24.46
Buena Vista	Ingleside	0.0%	0%		-13%	1907	2	32.26086957	27.90625
Northeast	Richmond Subarea4	0.0%	0%		-10%	2257	2	26.26811594	23.60377358
South Bayshore	Central	0.0%	0%		-8%	2506	2	28.328125	25.94274809
Central	South Inner Sunset	0.0%	0%		-12%	2685	2	18.31927711	16.07831325
South Bayshore	Northeast	0.0%	0%		-16%	3365	2	44.23913043	37.27083333
Bernal Heights	SF screenline south	0.0%	0%		-11%	4492	2	11.15957447	9.885321101

Origin Zone Name	Destination Zone Name	% of Total Volume		Percent of OD Volume		Travel Time		Fall 2019 Total Volume	Fall 2019 Volume Via 8th Ave	Fall 2019 Median Travel Time (mins)	Fall 2021 Median Travel Time (mins)
		on 8th Ave		Using 8th Ave		Travel Time Change (%)	Change (mins)				
Presidio	Presidio	0.0%		0%		-10%	-1.58	4614	2	15.08510638	13.50869565
Central	South of Market	0.0%		0%		-6%	-1.87	5036	2	30.85294118	28.98611111
Buena Vista	Mission	0.0%		0%		-8%	-1.73	5056	2	21.04666667	19.31395349
Western Addition	South of Market	0.0%		0%		-7%	-2.09	9624	2	31.57142857	29.48484848
South of Market	Northeast	0.0%		0%		-10%	-2.65	16007	2	27.5	24.84615385
Richmond LandsEnd	Bernal Heights	0.0%		4%				27	1		
Richmond LandsEnd	Richmond Subarea4	0.0%		1%				107	1	30.82231405	
Richmond LandsEnd	South Central	0.0%		1%				123	1	46.53773585	
South Central	Richmond LandsEnd	0.0%		1%				134	1		
Richmond LandsEnd	SF screenline north	0.0%		0%		-5%	-0.93	477	1	19.69444444	18.76923077
Richmond Subarea1	Richmond LandsEnd	0.0%		0%		+6%	+0.97	727	1	16.06589147	17.04054054
SF screenline south	Richmond LandsEnd	0.0%		0%		-8%	-2.07	863	1	27.25903614	25.19230769
Richmond Subarea1	Bernal Heights	0.0%		1%		-0%	-0.19	138	1	49.03306343	48.84162521
North Inner Sunset	South Bayshore	0.0%		0%		-17%	-7.02	651	1	41.80434783	34.78688525
South Inner Sunset	South Bayshore	0.0%		0%		-7%	-2.72	884	1	39.03488372	36.31355932
South Central	Buena Vista	0.0%		0%		-21%	-7.42	1335	1	35.95588235	28.53488372
Western Addition	Bernal Heights	0.0%		0%		-6%	-2.01	1476	1	35.19090909	33.18269231
Richmond Subarea4	South of Market	0.0%		0%		-4%	-1.46	1735	1	38.89215686	37.43421053
Richmond Subarea4	SF screenline north	0.0%		0%		-21%	-3.03	1988	1	14.54444444	11.51648352
Richmond Subarea4	Northeast	0.0%		0%		-9%	-2.45	2195	1	26.22307692	23.77777778
South of Market	Bernal Heights	0.0%		0%		-21%	-5.58	2899	1	26.16101695	20.58510638
Richmond Subarea4	Richmond Subarea4	0.0%		0%		-12%	-1.69	2932	1	13.60227273	11.91489362
South Bayshore	Bernal Heights	0.0%		0%		+8%	+1.37	2942	1	17.31052632	18.67647059
South Inner Sunset	South Central	0.0%		0%		+0%	+0.10	2980	1	27.47560976	27.57407407
South Central	South Inner Sunset	0.0%		0%		-13%	-3.45	2995	1	26.70408163	23.25862069
Downtown	Richmond Subarea4	0.0%		0%		-22%	-6.67	3380	1	30.30701754	23.63636364
Buena Vista	South of Market	0.0%		0%		+1%	+0.25	3739	1	28.03030303	28.27777778
Bernal Heights	Bernal Heights	0.0%		0%		-19%	-2.36	4004	1	12.3556701	10
SF screenline south	Bernal Heights	0.0%		0%		-29%	-3.45	4318	1	11.74761905	8.295454545
Central	South Central	0.0%		0%		-2%	-0.46	4572	1	23.44202899	22.97761194
Downtown	Central	0.0%		0%		-11%	-3.43	5299	1	31.00909091	27.57692308
Buena Vista	Central	0.0%		0%		-13%	-2.31	5647	1	18.17816092	15.86842105
Bernal Heights	Mission	0.0%		0%		-18%	-3.27	6385	1	17.71538462	14.44117647
South Central	South of Market	0.0%		0%		-23%	-7.34	8442	1	31.36956522	24.02857143
Mission	Central	0.0%		0%		-12%	-2.36	10984	1	19.3	16.94086022
Central	Mission	0.0%		0%		-4%	-0.81	11080	1	19.62820513	18.81578947
South Bayshore	South Central	0.0%		0%		-8%	-1.65	11612	1	20.02	18.36746988
Ingliside	South Inner Sunset	0.0%		0%		-17%	-3.20	14232	1	18.5	15.3
Presidio	Richmond LandsEnd	0.0%		0%				169	0	22.0106383	
Presidio	Richmond Subarea2	0.0%		0%		+6%	+1.01	859	0	16.92647059	17.93421053
Presidio	Marina	0.0%		0%		-4%	-0.79	3740	0	17.80136986	17.015625
Presidio	Bernal Heights	0.0%		0%		-9%	-4.65	123	0	48.93260188	44.28632479
Buena Vista	South Inner Sunset	0.0%		0%		-8%	-1.63	1173	0	21.5125	19.87804878
Buena Vista	South Bayshore	0.0%		0%		+2%	+0.63	1068	0	35	35.63333333
SF screenline north	SF screenline north	0.0%		0%				119787	0		
SF screenline north	Richmond LandsEnd	0.0%		0%		-15%	-2.98	536	0	19.29738562	16.31642512
SF screenline north	Richmond Subarea1	0.0%		0%		-18%	-2.91	1085	0	16.25268817	13.33969466

Origin Zone Name	Destination Zone Name on 8th Ave	% of Total Volume		Percent of OD Volume		Travel Time		Fall 2019 Total Volume	Fall 2019 Volume Via 8th Ave	Fall 2019 Median Travel Time (mins)	Fall 2021 Median Travel Time (mins)
		Using 8th Ave	Using 8th Ave	Travel Time Change (%)	Change (mins)						
SF screenline north	Richmond Subarea4	0.0%	0%		-11%	-1.73	1824	0	16.02447552	14.29166667	
Northeast	Bernal Heights	0.0%	0%		+14%	+5.50	733	0	40.2	45.69642857	
Ingleside	Richmond LandsEnd	0.0%	0%		-22%	-7.10	285	0	32.01851852	24.92105263	
Ingleside	Marina	0.0%	0%		-14%	-6.41	1438	0	45.75806452	39.35227273	
Ingleside	Bernal Heights	0.0%	0%		-14%	-3.34	2326	0	23.66176471	20.3245614	
Mission	South Inner Sunset	0.0%	0%		-18%	-5.23	1416	0	29.35483871	24.12337662	
Mission	Richmond Subarea4	0.0%	0%		+13%	+4.20	1050	0	31.42957746	35.63333333	
Central	Bernal Heights	0.0%	0%		-12%	-2.36	3041	0	19.93421053	17.57446809	
South Inner Sunset	Buena Vista	0.0%	0%		-5%	-1.16	1139	0	23.62280702	22.45833333	
South Inner Sunset	Mission	0.0%	0%		-0%	-0.04	1320	0	28.56060606	28.52469136	
South Inner Sunset	Central	0.0%	0%		-2%	-0.40	2815	0	17.54054054	17.1372549	
South Inner Sunset	SF screenline east	0.0%	0%		-8%	-3.67	813	0	44.74	41.06818182	
South Inner Sunset	South of Market	0.0%	0%		-14%	-5.78	1413	0	41.4137931	35.63432836	
South Inner Sunset	Bernal Heights	0.0%	0%		+9%	+2.65	528	0	28.62244898	31.2755102	
Richmond Subarea3	Presidio	0.0%	0%		+10%	+1.80	900	0	17.15333333	18.95	
North Inner Sunset	South Inner Sunset	0.0%	0%		-15%	-2.31	2986	0	15.91176471	13.60204082	
Richmond LandsEnd	Presidio	0.0%	0%		-3%	-0.56	158	0	26.27192982	15.72222222	
Richmond LandsEnd	Richmond LandsEnd	0.0%	0%		-13%	-2.18	342	0	16.28021978	14.0840708	
Richmond LandsEnd	Richmond Subarea1	0.0%	0%		-13%	-2.18	827	0	16.26699029	14.0840708	
Richmond LandsEnd	Richmond Subarea2	0.0%	0%		-13%	-2.18	308	0	19.17878788		
Richmond LandsEnd	Marina	0.0%	0%		-13%	-2.18	68	0			
SF screenline east	Central	0.0%	0%		-24%	-7.57	2201	0	31.52105263	23.95508982	
SF screenline east	South Inner Sunset	0.0%	0%		-14%	-5.57	866	0	38.8220339	33.24736842	
SF screenline east	SF screenline east	0.0%	0%		-14%	-5.57	235474	0			
SF screenline east	Bernal Heights	0.0%	0%		-34%	-9.59	1044	0	28.43506494	18.84285714	
SF screenline east	South Bayshore	0.0%	0%		-23%	-5.68	5852	0	24.9368932	19.26033058	
Richmond Subarea2	Richmond LandsEnd	0.0%	0%		-23%	-5.68	280	0	13.8537415		
Richmond Subarea4	Presidio	0.0%	0%		+7%	+1.00	1146	0	15.14705882	16.14705882	
Richmond Subarea4	Richmond LandsEnd	0.0%	0%		-11%	-1.87	120	0			
Richmond Subarea4	Marina	0.0%	0%		-11%	-1.87	3582	0	16.84246575	14.97311828	
Richmond Subarea4	Bernal Heights	0.0%	0%		-9%	-3.10	180	0	44.56185567		
Marina	Mission	0.0%	0%		-9%	-3.10	3306	0	35.56382979	32.46341463	
Marina	Richmond LandsEnd	0.0%	0%		-17%	-3.01	128	0	34.87864078		
Marina	Richmond Subarea4	0.0%	0%		-17%	-3.01	3860	0	17.2972973	14.28723404	
Marina	Marina	0.0%	0%		-6%	-0.91	18154	0	14.23958333	13.33168317	
Marina	Bernal Heights	0.0%	0%		-12%	-5.30	449	0	45.07692308	39.77941176	
Marina	South Bayshore	0.0%	0%		+3%	+1.18	1096	0	45.70289855	46.88095238	
Marina	South Central	0.0%	0%		-3%	-1.34	1313	0	48.74061433	47.40540541	
SF screenline south	SF screenline south	0.0%	0%		-3%	-1.34	267502	0			
Outer Sunset	Richmond LandsEnd	0.0%	0%		-25%	-9.71	631	0	20.02272727		
Outer Sunset	Bernal Heights	0.0%	0%		-25%	-9.71	662	0	39.41071429	29.7027972	
South of Market	South Inner Sunset	0.0%	0%		-21%	-7.88	1326	0	37.69607843	29.81818182	
South of Market	South Bayshore	0.0%	0%		-12%	-3.02	9386	0	25.25757576	22.23913043	
Bernal Heights	Buena Vista	0.0%	0%		-14%	-3.11	646	0	27.25		
Bernal Heights	Ingleside	0.0%	0%		-15%	-2.65	2355	0	22.453125	19.33870968	
Bernal Heights	Central	0.0%	0%		-15%	-2.65	3000	0	17.62162162	14.96774194	
Bernal Heights	South Inner Sunset	0.0%	0%		-8%	-1.92	579	0	25.43203883	23.508	

Origin Zone Name	Destination Zone Name on 8th Ave	% of Total Volume		Travel Time		Fall 2019 Total Volume	Fall 2019 Volume Via 8th Ave	Fall 2019 Median Travel Time (mins)	Fall 2021 Median Travel Time (mins)
		Using 8th Ave	Percent of OD Volume	Change (%)	Change (mins)				
Bernal Heights	North Inner Sunset	0.0%	0%	+8%	+2.00	452	0	26	28
Bernal Heights	Richmond LandsEnd	0.0%	0%			17	0		
Bernal Heights	Richmond Subarea4	0.0%	0%			209	0	42.98507463	
Bernal Heights	Marina	0.0%	0%			534	0	45.625	
Bernal Heights	Outer Sunset	0.0%	0%	-14%	-4.82	707	0	35.15441176	30.33802817
Bernal Heights	South of Market	0.0%	0%	-2%	-0.63	3269	0	25.66666667	25.03731343
Bernal Heights	South Bayshore	0.0%	0%	-18%	-3.43	3179	0	19.20588235	15.7755102
Bernal Heights	South Central	0.0%	0%	-18%	-3.40	4309	0	18.75333333	15.3556701
South Bayshore	Mission	0.0%	0%	-5%	-1.11	8182	0	23.90350877	22.79310345
South Bayshore	South Inner Sunset	0.0%	0%	-6%	-1.95	854	0	32.76785714	30.81851852
South Bayshore	Richmond LandsEnd	0.0%	0%			76	0		
South Bayshore	Marina	0.0%	0%	-25%	-11.61	1112	0	45.85	34.23880597
South Central	Marina	0.0%	0%	-16%	-7.59	1402	0	46.62765957	39.03488372
South Central	Bernal Heights	0.0%	0%	-8%	-1.46	4005	0	17.65789474	16.20175439

Appendix B: JFK Drive Screenline Volume and Travel Time Results

Origin Zone Name	Destination Zone Name	% of Total		Percent of OD		Travel Time		Fall 2019 Total Volume	Fall 2019 Volume Via JFK	Fall 2019 Median Travel Time (mins)	Fall 2021 Median Travel Time (mins)
		Volume on JFK	Volume Using JFK	Travel Time Change (%)	Change (mins)						
Western Addition	Outer Sunset	2.3%	5%	-8%	-2.46	6284	331	32.75423729	30.29104478		
Western Addition	Golden Gate Park	2.2%	16%	-1%	-0.15	2014	324	22.48	22.33333333		
Golden Gate Park	Buena Vista	1.7%	21%	-17%	-3.54	1205	251	20.35185185	16.80769231		
Golden Gate Park	Western Addition	1.7%	10%	-0%	-0.04	2375	245	21.19117647	21.15384615		
South of Market	Richmond Subarea1	1.6%	15%	-22%	-10.89	1569	236	48.97928994	38.09375		
Golden Gate Park	Golden Gate Park	1.5%	13%	-4%	-0.66	1737	225	15.84042553	15.17768595		
Downtown	Outer Sunset	1.5%	4%	-12%	-5.97	5626	223	48.16	42.19014085		
Richmond Subarea1	South of Market	1.5%	12%	-0%	-0.14	1750	213	48.72413793	48.58728653		
SF screenline east	Golden Gate Park	1.3%	35%	-12%	-4.05	558	197	34.86734694	30.82142857		
Mission	Richmond Subarea1	1.3%	18%	-14%	-6.29	1063	192	43.58860759	37.29411765		
Buena Vista	Golden Gate Park	1.3%	18%	-7%	-1.62	1079	191	22.34615385	20.72222222		
SF screenline east	Richmond Subarea1	1.3%	23%	-12%	-5.08	809	185	43.6	38.515625		
Richmond Subarea1	SF screenline east	1.2%	22%	-0%	-0.07	819	181	48.75127334	48.68512397		
Outer Sunset	Downtown	1.0%	3%	-12%	-5.10	5821	146	43.35	38.25257732		
Mission	Richmond Subarea2	1.0%	17%	-11%	-4.58	801	139	41.03333333	36.45238095		
Downtown	Richmond Subarea1	0.9%	3%	-7%	-2.97	3884	134	44.90350877	41.93478261		
Western Addition	North of Inner Sunset	0.9%	4%	-3%	-0.80	3731	133	24.72033898	23.91791045		
Western Addition	SF screenline south	0.9%	1%	-8%	-2.44	11461	128	31.81746032	29.375		
South of Market	Richmond Subarea2	0.9%	10%	-19%	-8.76	1277	127	47.1984127	38.43650794		
Northeast	Golden Gate Park	0.8%	21%	+2%	+0.78	588	123	38.08490566	38.86363636		
SF screenline east	Richmond Subarea2	0.8%	16%	-9%	-3.93	771	121	43.51190476	39.57792208		
SF screenline north	North of Inner Sunset	0.8%	9%	-2%	-0.54	1252	116	25.35294118	24.81360947		
Western Addition	Ingleside	0.8%	2%	-5%	-1.86	5022	116	38.78787879	36.92465753		
Richmond Subarea1	Downtown	0.8%	3%	-6%	-2.74	4037	115	42.86956522	40.12666667		
Golden Gate Park	SF screenline east	0.8%	19%	+1%	+0.57	617	115	38.46153846	39.03333333		
Mission	Golden Gate Park	0.8%	23%	-8%	-2.84	486	114	33.87755102	31.036		
Golden Gate Park	Downtown	0.8%	10%	-7%	-2.48	1155	113	36.59677419	34.11971831		
Outer Sunset	Western Addition	0.8%	2%	-14%	-4.52	6208	112	31.5	26.98387097		
Downtown	Golden Gate Park	0.7%	13%	-11%	-4.20	828	109	38.68421053	34.48684211		
Richmond Subarea3	Buena Vista	0.7%	9%	+6%	+1.54	1157	107	24.08571429	25.625		
SF screenline east	Outer Sunset	0.7%	5%	-20%	-8.62	1970	107	43.82258065	35.19892473		
SF screenline east	Richmond LandsEnd	0.7%	42%			252	106		36.10913706		
South of Market	Outer Sunset	0.7%	3%	-22%	-10.32	3592	104	47.44545455	37.12857143		
Richmond Subarea2	South of Market	0.7%	8%	+7%	+3.08	1350	102	43.75862069	46.8372093		
Richmond Subarea2	SF screenline east	0.7%	13%	+1%	+0.43	735	96	47.59448819	48.02631579		
SF screenline east	Richmond Subarea3	0.6%	8%	-24%	-9.36	1128	95	38.32432432	28.96031746		
South of Market	Richmond Subarea3	0.6%	5%	-34%	-16.12	1803	95	47.87209302	31.75252525		
Richmond Subarea3	Mission	0.6%	8%	-15%	-5.96	1250	94	38.75531915	32.8		
South of Market	Golden Gate Park	0.6%	19%	+13%	+5.03	492	92	38.72222222	43.75		
Mission	Richmond Subarea3	0.6%	7%	-7%	-2.62	1356	91	37.5	34.88356164		
Richmond Subarea2	Mission	0.6%	11%	-1%	-0.51	806	90	39.29012346	38.7804878		
SF screenline north	Buena Vista	0.6%	12%	-11%	-3.19	736	89	28.48275862	25.29230769		

Origin Zone Name	Destination Zone Name	% of Total		Percent of OD		Travel Time		Fall 2019 Total Volume	Fall 2019 Volume Via JFK	Fall 2019 Median Travel Time (mins)	Fall 2021 Median Travel Time (mins)
		Volume on JFK	Volume Using JFK	Travel Time Change (%)	Change (mins)						
Richmond Subarea1	Mission	0.6%	8%	-9%	-4.13	1083	86	44.02173913	39.8880597		
Golden Gate Park	Mission	0.6%	13%	-18%	-7.07	649	85	39.15	32.08461538		
Golden Gate Park	Central	0.6%	11%	-2%	-0.49	796	84	28.55	28.05555556		
Mission	Outer Sunset	0.6%	3%	-20%	-8.41	3171	84	42.58474576	34.17692308		
Buena Vista	Outer Sunset	0.6%	2%	-15%	-4.54	3695	83	30.59090909	26.0505618		
Golden Gate Park	South of Market	0.6%	11%	+7%	+2.54	769	82	35.54166667	38.08536585		
Western Addition	Richmond Subarea1	0.6%	2%	-12%	-3.49	4931	82	28.63333333	25.14556962		
Richmond Subarea1	Buena Vista	0.6%	14%	-9%	-2.91	574	81	32.86956522	29.95588235		
Outer Sunset	Mission	0.5%	2%	-8%	-3.12	3425	79	38.09016393	34.97457627		
SF screenline east	SF screenline south	0.5%	0%	-34%	-6.42	20120	79	19.14534884	12.72929936		
Richmond Subarea2	Buena Vista	0.5%	12%	-7%	-1.82	650	77	25	23.18095238		
Northeast	Outer Sunset	0.5%	2%	-10%	-4.72	3062	75	48.70486111	43.98		
Buena Vista	Richmond Subarea3	0.5%	6%	+3%	+0.64	1156	74	22.64814815	23.29166667		
Buena Vista	Richmond Subarea2	0.5%	13%	-4%	-1.13	588	74	26.875	25.74468085		
Outer Sunset	Buena Vista	0.5%	2%	-6%	-1.67	3465	71	28.97222222	27.29746835		
Outer Sunset	South of Market	0.5%	2%	-6%	-2.66	3778	71	42.30952381	39.65217391		
SF screenline south	Golden Gate Park	0.5%	5%	+3%	+0.74	1293	70	27.10294118	27.84615385		
Richmond Subarea4	Golden Gate Park	0.5%	12%	+12%	+2.35	586	69	19.47368421	21.82743363		
Richmond Subarea1	Western Addition	0.5%	1%	-4%	-1.10	5011	68	28.39873418	27.30232558		
Golden Gate Park	SF screenline south	0.5%	4%	-2%	-0.48	1610	68	25.3313253	24.84782609		
Richmond Subarea3	SF screenline east	0.5%	7%	-8%	-3.68	975	67	44.82142857	41.14150943		
Downtown	SF screenline south	0.5%	0%	-25%	-6.86	23680	66	27.75	20.88636364		
SF screenline north	Central	0.4%	8%	+1%	+0.35	840	64	35.09793814	35.44827586		
SF screenline south	Western Addition	0.4%	1%	-15%	-5.11	11060	64	34.47402597	29.36585366		
Western Addition	Richmond Subarea2	0.4%	2%	-8%	-1.91	4026	62	23.06470588	21.15		
North of Inner Sunset	Western Addition	0.4%	2%	-17%	-4.52	3525	62	25.81818182	21.3030303		
Western Addition	SF screenline north	0.4%	2%	-15%	-3.34	3977	61	21.68421053	18.34705882		
Buena Vista	SF screenline north	0.4%	7%	-12%	-3.43	824	60	29.02631579	25.5974026		
South of Market	Mission	0.4%	0%	-18%	-3.95	18173	60	22.00819672	18.0625		
Mission	SF screenline north	0.4%	4%	-19%	-7.02	1416	59	37.20103093	30.17961165		
Richmond Subarea3	South of Market	0.4%	3%	+1%	+0.44	1793	58	39.40909091	39.85		
Marina	Outer Sunset	0.4%	3%	-4%	-1.61	1949	58	39.31034483	37.70430108		
SF screenline south	Richmond Subarea2	0.4%	2%	-5%	-1.68	2300	56	30.77272727	29.09677419		
SF screenline north	Mission	0.4%	4%	+3%	+1.21	1299	55	40.32608696	41.53488372		
Richmond Subarea3	Golden Gate Park	0.4%	6%	-27%	-5.20	916	55	19.61111111	14.41176471		
Buena Vista	Richmond Subarea1	0.4%	9%	-13%	-3.96	620	55	31.40322581	27.44262295		
SF screenline south	Richmond Subarea3	0.4%	2%	-16%	-5.36	2965	54	33.51351351	28.15686275		
SF screenline south	SF screenline east	0.4%	0%	-16%	-4.73	19116	54	29.56666667	24.83333333		
Downtown	North of Inner Sunset	0.4%	2%	-16%	-6.36	2557	53	38.84375	32.48717949		
SF screenline south	Downtown	0.4%	0%	-24%	-7.76	23137	53	32.65277778	24.89534884		
Richmond Subarea3	North of Inner Sunset	0.4%	4%	+6%	+1.36	1278	52	21.51587302	22.87755102		
Richmond Subarea2	SF screenline south	0.4%	2%	+7%	+2.01	2548	52	28.43939394	30.44936709		

Origin Zone Name	Destination Zone Name	% of Total		Percent of OD		Travel Time		Fall 2019 Total Volume	Fall 2019 Volume Via JFK	Fall 2019 Median Travel Time (mins)	Fall 2021 Median Travel Time (mins)
		Volume on JFK	Volume Using JFK	Travel Time Change (%)	Change (mins)						
Richmond Subarea3	SF screenline south	0.4%	2%	+6%	+1.87	2838	52	31.234375	33.1		
Central	Golden Gate Park	0.3%	8%	+5%	+1.43	622	51	30	31.43333333		
Richmond Subarea1	Central	0.3%	7%	-3%	-1.11	687	50	37.59615385	36.48717949		
Richmond Subarea2	Western Addition	0.3%	1%	-3%	-0.75	4043	50	21.9084507	21.16197183		
North of Inner Sunset	Golden Gate Park	0.3%	4%	-0%	-0.08	1212	49	18.59589041	18.51369863		
Outer Sunset	SF screenline east	0.3%	2%	-2%	-1.02	2093	48	48.53646833	47.51333333		
Golden Gate Park	Richmond Subarea3	0.3%	3%	-11%	-1.87	1376	48	17.40410959	15.53191489		
Marina	Golden Gate Park	0.3%	8%	-11%	-3.49	593	47	31.17391304	27.68666667		
Golden Gate Park	Northeast	0.3%	6%	-15%	-6.39	854	47	42	35.60810811		
Richmond Subarea1	Ingleside	0.3%	1%	-5%	-1.68	3323	45	34.33333333	32.64864865		
South of Market	SF screenline south	0.3%	0%	-29%	-5.39	27410	45	18.86486486	13.47777778		
Richmond Subarea3	South Bayshore	0.3%	7%	-1%	-0.31	676	44	48.90764331	48.59689214		
Golden Gate Park	Outer Sunset	0.3%	1%	-1%	-0.25	3344	43	17.29761905	17.05140187		
Golden Gate Park	North of Inner Sunset	0.3%	3%	-4%	-0.69	1606	43	17.1	16.41011236		
Outer Sunset	Northeast	0.3%	1%	-10%	-4.33	3308	43	44.36111111	40.03125		
SF screenline south	Richmond Subarea1	0.3%	1%	-10%	-2.80	3592	41	28.57058824	25.77433628		
SF screenline east	SF screenline north	0.3%	5%	-31%	-14.78	756	40	47.46153846	32.67777778		
Richmond Subarea2	Central	0.3%	7%	-8%	-2.41	570	39	31.8	29.39473684		
Richmond Subarea3	Central	0.3%	6%	+6%	+1.73	622	39	30.25862069	31.98837209		
Central	Richmond Subarea3	0.3%	6%	-2%	-0.53	706	39	30.60377358	30.06896552		
South of Market	North of Inner Sunset	0.3%	1%	-9%	-3.48	2544	38	39.671875	36.19333333		
SF screenline south	South of Market	0.3%	0%	-15%	-3.50	27725	38	22.61290323	19.1125		
SF screenline south	SF screenline north	0.3%	0%	-4%	-1.12	8384	37	29.6056338	28.48787879		
South Bayshore	Golden Gate Park	0.3%	14%	-7%	-2.80	274	37	37.51492537	34.71804511		
SF screenline north	Golden Gate Park	0.3%	5%	-14%	-2.78	682	37	20.51136364	17.73566879		
Ingleside	Western Addition	0.3%	1%	-7%	-2.68	5026	37	39.71428571	37.03409091		
Central	Richmond Subarea1	0.3%	5%	-10%	-3.85	724	37	39.3	35.44736842		
Downtown	Richmond Subarea2	0.3%	1%	-18%	-7.26	3368	37	39.93939394	32.68292683		
Richmond Subarea2	South Central	0.2%	4%	+7%	+3.01	883	36	45.60526316	48.61948529		
Richmond Subarea2	Golden Gate Park	0.2%	5%	+12%	+2.10	678	36	17.26388889	19.36585366		
South Bayshore	Richmond Subarea2	0.2%	9%	-8%	-3.59	381	36	44.84285714	41.2518797		
Mission	South Bayshore	0.2%	0%	-12%	-3.05	8398	36	25.48113208	22.42647059		
South Bayshore	SF screenline north	0.2%	5%	-20%	-9.70	655	36	48.41044776	38.71111111		
SF screenline north	SF screenline south	0.2%	0%	+6%	+1.72	7920	35	28.22173913	29.94099379		
Richmond Subarea4	Outer Sunset	0.2%	2%	-9%	-2.62	1773	35	29.5	26.87804878		
North of Inner Sunset	Richmond Subarea3	0.2%	2%	-2%	-0.35	1533	35	21.36363636	21.0170068		
South of Inner Sunset	Golden Gate Park	0.2%	6%	-6%	-1.25	555	35	22.1509434	20.9057971		
Richmond Subarea2	South Bayshore	0.2%	8%	-0%	-0.06	419	33	48.69473684	48.63577982		
SF screenline north	South of Market	0.2%	1%	-4%	-1.79	3901	33	44.29310345	42.5		
Western Addition	Richmond Subarea3	0.2%	0%	-16%	-3.05	6922	33	18.97619048	15.92682927		
Downtown	Richmond Subarea3	0.2%	1%	-24%	-8.49	4403	33	34.77118644	26.2826087		
South of Market	Ingleside	0.2%	1%	-18%	-6.27	5145	32	34.05319149	27.77868852		

Origin Zone Name	Destination Zone Name	Percent of OD		Travel Time Change (%)	Travel Time Change (mins)	Fall 2019 Total Volume	Fall 2019 Volume Via JFK	Fall 2019 Median Travel Time (mins)	Fall 2021 Median Travel Time (mins)
		% of Total Volume on JFK	Percent of OD Volume Using JFK						
Western Addition	Western Addition	0.2%	0%	-6%	-0.89	27090	31	15.38888889	14.5
Outer Sunset	Golden Gate Park	0.2%	1%	-2%	-0.26	2166	31	17.23684211	16.97674419
Downtown	SF screenline north	0.2%	0%	-25%	-8.36	6788	31	33.66	25.29807692
SF screenline south	Buena Vista	0.2%	1%	-6%	-1.63	3105	30	26.69354839	25.06
Golden Gate Park	Richmond Subarea1	0.2%	2%	-11%	-1.83	1515	30	16.03623188	14.20833333
Ingleside	Richmond Subarea4	0.2%	2%	-10%	-3.74	1309	30	39.16666667	35.42783505
Bernal Heights	Richmond Subarea3	0.2%	14%			217	30	46.18085106	
Richmond Subarea3	Western Addition	0.2%	0%	-10%	-1.93	6455	28	18.95588235	17.02631579
Golden Gate Park	SF screenline north	0.2%	3%	-5%	-0.97	909	28	18.69117647	17.72147651
North of Inner Sunset	Downtown	0.2%	1%	-8%	-2.80	2760	28	34.51960784	31.72413793
South Bayshore	SF screenline south	0.2%	0%	-9%	-1.18	15344	28	13.49056604	12.30582524
South Bayshore	Richmond Subarea1	0.2%	3%	-10%	-4.60	795	27	48.34375	43.74561404
Golden Gate Park	Ingleside	0.2%	2%	-7%	-1.92	1327	27	27.96296296	26.04166667
South of Inner Sunset	Western Addition	0.2%	1%	-16%	-4.74	2103	27	29.31538462	24.57692308
Northeast	SF screenline south	0.2%	0%	-16%	-6.25	11606	27	38.2	31.94776119
South of Market	SF screenline north	0.2%	1%	-18%	-7.41	3965	27	40.13768116	32.73076923
SF screenline north	South Bayshore	0.2%	4%	-0%	-0.02	608	26	48.86507937	48.84983498
Richmond Subarea2	North of Inner Sunset	0.2%	3%	-14%	-3.08	996	26	22.73376623	19.65346535
SF screenline south	Richmond Subarea4	0.2%	1%	-10%	-3.40	1889	26	35.23626374	31.83333333
SF screenline east	Presidio	0.2%	5%	-10%	-3.88	560	26	39.23255814	35.34962406
Golden Gate Park	South Bayshore	0.2%	11%	-6%	-2.30	247	26	41.5	39.19852941
Richmond Subarea4	North of Inner Sunset	0.2%	3%	-4%	-0.84	915	25	21.46031746	20.61764706
Richmond Subarea3	Downtown	0.2%	1%	-7%	-2.34	4074	25	33.23170732	30.89370079
Central	SF screenline north	0.2%	3%	-2%	-0.70	942	25	31.58139535	30.88317757
Downtown	Northeast	0.2%	0%	-16%	-3.56	42297	25	22.30327869	18.74358974
SF screenline south	Mission	0.2%	0%	-17%	-3.47	13090	25	20.34615385	16.87179487
SF screenline south	Northeast	0.2%	0%	-20%	-7.79	11551	25	38.12318841	30.33544304
Mission	Richmond LandsEnd	0.2%	21%			120	25		
Richmond Subarea3	South Central	0.2%	2%	-4%	-1.71	973	24	46.47674419	44.765625
Richmond Subarea3	Ingleside	0.2%	1%	-3%	-0.97	2169	24	33.925	32.95833333
Richmond Subarea2	Downtown	0.2%	1%	-12%	-4.43	3336	24	38.32608696	33.89215686
Western Addition	South of Inner Sunset	0.2%	1%	-5%	-1.62	1987	24	30.98684211	29.36666667
Ingleside	South of Market	0.2%	0%	-13%	-4.67	5494	24	35.56521739	30.89622642
SF screenline south	Marina	0.2%	1%	-14%	-5.55	4646	24	39.05	33.5
SF screenline east	Downtown	0.2%	0%	-26%	-5.58	26130	24	21.14285714	15.56603774
North of Inner Sunset	Northeast	0.2%	2%	-9%	-3.41	1235	23	39.38235294	35.96969697
Mission	North of Inner Sunset	0.2%	1%	-10%	-3.51	1858	23	34.63793103	31.12903226
South Bayshore	Outer Sunset	0.2%	1%	-11%	-4.43	2345	23	40.89726027	36.46774194
Outer Sunset	Outer Sunset	0.2%	0%	-12%	-1.60	47035	23	13.88095238	12.28217822
Central	Downtown	0.2%	0%	-1%	-0.44	5262	22	30.70930233	30.26842105
Richmond Subarea1	Golden Gate Park	0.2%	2%	+1%	+0.23	978	22	16.04929577	16.27464789
Golden Gate Park	Marina	0.2%	3%	-15%	-4.59	648	22	29.86734694	25.27906977

Origin Zone Name	Destination Zone Name	% of Total		Percent of OD		Travel Time		Fall 2019 Total Volume	Fall 2019 Volume Via JFK	Fall 2019 Median Travel Time (mins)	Fall 2021 Median Travel Time (mins)
		Volume on JFK	Volume Using JFK	Travel Time Change (%)	Change (mins)						
SF screenline south	Outer Sunset	0.2%	0%		-13%	-2.82	17429	22	21.1741573	18.35714286	
Marina	North of Inner Sunset	0.1%	2%		+20%	+6.79	946	21	33.47435897	40.26666667	
Presidio	Mission	0.1%	4%		+12%	+4.95	481	21	41.14	46.09090909	
Richmond Subarea2	Bernal Heights	0.1%	17%				126	21	43.11751152		
Buena Vista	SF screenline south	0.1%	1%		-3%	-0.86	3194	21	24.71917808	23.86363636	
Downtown	SF screenline east	0.1%	0%		-9%	-1.58	22529	21	18.44029851	16.8625	
Western Addition	Northeast	0.1%	0%		-12%	-3.05	9868	21	24.93548387	21.88983051	
Mission	SF screenline south	0.1%	0%		-13%	-2.34	13307	21	18.63580247	16.3	
Golden Gate Park	Richmond Subarea2	0.1%	2%		-4%	-0.60	927	21	16.325	15.72368421	
Downtown	Ingleside	0.1%	1%		-26%	-11.66	4155	21	45.18627451	33.52941176	
Outer Sunset	SF screenline south	0.1%	0%		-4%	-0.74	17977	20	17.65909091	16.91666667	
SF screenline north	Downtown	0.1%	0%		-6%	-1.98	6506	20	34.44736842	32.46551724	
Northeast	Mission	0.1%	0%		-9%	-3.31	5307	20	38.14516129	34.83333333	
SF screenline east	Western Addition	0.1%	0%		-19%	-5.66	6857	20	29.0212766	23.36507937	
Richmond LandsEnd	SF screenline east	0.1%	12%				162	19	49.20728643		
Richmond Subarea4	SF screenline south	0.1%	1%		+6%	+1.96	1934	19	33.64084507	35.59734513	
Western Addition	Downtown	0.1%	0%		-11%	-2.47	24168	19	21.56578947	19.1	
Marina	Richmond Subarea1	0.1%	1%		-16%	-5.02	1466	19	30.93333333	25.91666667	
Northeast	Richmond Subarea1	0.1%	1%		-16%	-7.15	2074	19	43.77118644	36.625	
North of Inner Sunset	SF screenline east	0.1%	1%		-1%	-0.54	1922	18	42.29746835	41.75490196	
Richmond Subarea3	South of Inner Sunset	0.1%	3%		+8%	+2.13	716	18	26.49056604	28.61764706	
SF screenline east	South of Market	0.1%	0%		-6%	-1.27	19636	18	19.98571429	18.71212121	
South of Market	South of Market	0.1%	0%		-10%	-1.69	57843	18	17.5875	15.89759036	
Downtown	Western Addition	0.1%	0%		-19%	-4.68	23356	18	24.5	19.81884058	
Mission	Presidio	0.1%	4%		+8%	+3.56	433	17	42.8125	46.375	
Northeast	North of Inner Sunset	0.1%	2%		+2%	+0.86	1070	17	43.55882353	44.42156863	
Richmond Subarea4	Ingleside	0.1%	1%		+2%	+0.78	1217	17	36.78767123	37.56976744	
Richmond Subarea1	SF screenline south	0.1%	0%		-4%	-1.10	3415	17	27.42063492	26.32352941	
SF screenline north	Western Addition	0.1%	1%		-7%	-1.68	3367	17	22.85714286	21.17532468	
Marina	SF screenline south	0.1%	0%		-10%	-3.87	4695	17	39.89622642	36.02857143	
Northeast	Richmond Subarea3	0.1%	1%		-11%	-3.60	2432	17	32.46825397	28.87234043	
SF screenline east	North of Inner Sunset	0.1%	1%		-14%	-5.26	2037	17	37.89784946	32.63846154	
SF screenline south	Ingleside	0.1%	0%		-20%	-2.39	31662	17	11.85555556	9.468992248	
SF screenline north	Bernal Heights	0.1%	7%				256	17	46.2184466		
Western Addition	Central	0.1%	0%		-1%	-0.20	5063	16	25.68309859	25.48113208	
SF screenline north	SF screenline east	0.1%	2%		-1%	-0.60	701	16	49.14605263	48.54615385	
Western Addition	Buena Vista	0.1%	0%		-2%	-0.36	7399	16	17.85135135	17.48734177	
Richmond Subarea1	South Bayshore	0.1%	2%		+0%	+0.19	687	16	48.95288754	49.14130435	
North of Inner Sunset	South of Market	0.1%	1%		-6%	-2.41	2572	16	39.74193548	37.33185841	
Central	Western Addition	0.1%	0%		-8%	-2.05	5215	16	24.58108108	22.53333333	
Marina	Central	0.1%	1%		-11%	-3.93	1561	16	36.72727273	32.7972973	
Mission	SF screenline east	0.1%	0%		-11%	-3.22	7084	16	28.14935065	24.93209877	

Origin Zone Name	Destination Zone Name	% of Total	Percent of OD	Travel Time		Fall 2019 Total Volume	Fall 2019 Volume Via JFK	Fall 2019 Median Travel Time (mins)	Fall 2021 Median Travel Time (mins)	
		Volume on JFK	Volume Using JFK	Travel Time Change (%)	Change (mins)					
Buena Vista	North of Inner Sunset	0.1%	0%		-14%	-2.55	3677	16	17.9875	15.43641618
Golden Gate Park	Richmond Subarea4	0.1%	2%		-13%	-2.57	733	16	20.23529412	17.6656051
SF screenline east	Buena Vista	0.1%	1%		-16%	-4.60	1937	16	28.86363636	24.26744186
Downtown	Presidio	0.1%	1%		-23%	-9.15	1518	16	40.15217391	31
South of Market	SF screenline east	0.1%	0%		+5%	+0.70	25358	15	14.69047619	15.39333333
Western Addition	Presidio	0.1%	1%		+4%	+0.85	1441	15	23.26344086	24.1119403
North of Inner Sunset	Buena Vista	0.1%	0%		-4%	-0.64	3767	15	17.13709677	16.5
Richmond Subarea3	Bernal Heights	0.1%	8%				177	15	42.14893617	
Richmond Subarea3	Northeast	0.1%	1%		-5%	-1.88	2253	15	34.5212766	32.6443299
Buena Vista	Ingleside	0.1%	1%		-13%	-4.35	1907	15	32.26086957	27.90625
Golden Gate Park	South of Inner Sunset	0.1%	2%		-7%	-1.53	645	15	20.48148148	18.95588235
South Bayshore	Downtown	0.1%	0%		-21%	-8.96	6140	15	41.875	32.91818182
Northeast	Downtown	0.1%	0%		+0%	+0.04	44479	14	20.59090909	20.63157895
Richmond LandsEnd	Mission	0.1%	12%				116	14	46.41860465	
Richmond Subarea1	North of Inner Sunset	0.1%	1%		-9%	-2.11	1151	14	24.453125	22.34210526
Mission	Mission	0.1%	0%		-9%	-1.36	39570	14	15.96428571	14.60638298
SF screenline south	Central	0.1%	0%		-10%	-1.80	6354	14	17.73076923	15.92696629
Downtown	Downtown	0.1%	0%		-12%	-2.09	77650	14	17.44505495	15.35106383
Mission	Northeast	0.1%	0%		-16%	-5.49	5394	14	33.36363636	27.86986301
Western Addition	SF screenline east	0.1%	0%		-17%	-6.23	6372	14	36.55970149	30.32716049
Mission	Western Addition	0.1%	0%		-18%	-5.03	8462	14	28.2037037	23.17142857
SF screenline east	Northeast	0.1%	0%		-21%	-4.84	11643	14	23.53225806	18.68823529
Richmond Subarea4	Buena Vista	0.1%	1%		-8%	-1.51	1530	13	19.92168675	18.41428571
South Central	Western Addition	0.1%	0%		-5%	-1.99	4848	13	38.40243902	36.4122807
Mission	Downtown	0.1%	0%		-8%	-1.92	15895	13	24.25925926	22.33544304
Northeast	South of Inner Sunset	0.1%	2%		-10%	-4.61	785	13	46.47142857	41.86
Ingleside	Golden Gate Park	0.1%	1%		-2%	-0.43	984	13	27.78571429	27.35185185
Mission	Buena Vista	0.1%	0%		-11%	-2.55	5111	13	22.52777778	19.97297297
South Central	Golden Gate Park	0.1%	3%		-13%	-5.21	424	13	38.76666667	33.55813953
South of Market	Downtown	0.1%	0%		-12%	-2.27	45557	13	19.28378378	17.01612903
Ingleside	SF screenline south	0.1%	0%		-16%	-1.84	32166	13	11.375	9.538461538
South of Market	Buena Vista	0.1%	0%		-17%	-5.39	3688	13	30.85849057	25.47101449
South Bayshore	Western Addition	0.1%	1%		-18%	-7.53	2484	13	41.04166667	33.51449275
Downtown	Marina	0.1%	0%		-24%	-6.99	10748	13	28.75490196	21.76530612
North of Inner Sunset	Richmond Subarea1	0.1%	1%		-7%	-1.64	1126	12	23.51298701	21.87362637
Outer Sunset	Central	0.1%	0%		-10%	-2.87	2695	12	29.80434783	26.93548387
Richmond LandsEnd	Golden Gate Park	0.1%	6%				203	12	20.77142857	
Ingleside	SF screenline east	0.1%	0%		-14%	-6.29	3797	12	43.42424242	37.13218391
South of Market	Western Addition	0.1%	0%		-15%	-4.96	9116	12	32.97457627	28.015625
Golden Gate Park	South Central	0.1%	2%		+11%	+4.12	615	12	37.21186441	41.33333333
SF screenline east	Richmond Subarea4	0.1%	1%		-26%	-9.12	1127	12	34.54	25.41764706
Western Addition	Richmond LandsEnd	0.1%	3%				409	12	31.76666667	

Origin Zone Name	Destination Zone Name	% of Total		Percent of OD		Travel Time		Fall 2019 Total Volume	Fall 2019 Volume Via JFK	Fall 2019 Median Travel Time (mins)	Fall 2021 Median Travel Time (mins)
		Volume on JFK	Volume Using JFK	Travel Time Change (%)	Change (mins)						
South Bayshore	Richmond Subarea3	0.1%	2%	-0%	-0.12	615	11	48.73426573	48.6149635		
Mission	Marina	0.1%	0%	-3%	-0.89	3271	11	31.28125	30.3961039		
South Central	Richmond Subarea1	0.1%	1%	-4%	-1.95	1166	11	43.51470588	41.56779661		
Richmond Subarea3	Richmond Subarea3	0.1%	0%	-10%	-1.32	4436	11	13.77272727	12.45283019		
Marina	Downtown	0.1%	0%	-5%	-1.49	10730	11	27.81666667	26.32608696		
Outer Sunset	North of Inner Sunset	0.1%	0%	-11%	-2.03	6974	11	18.39041096	16.36075949		
Marina	SF screenline east	0.1%	0%	-13%	-4.88	2832	11	37.64084507	32.76190476		
SF screenline south	North of Inner Sunset	0.1%	0%	-13%	-3.09	4443	11	23.70238095	20.61111111		
Bernal Heights	Golden Gate Park	0.1%	11%			100	11				
Presidio	Central	0.1%	2%	-14%	-5.72	565	11	41.71428571	35.99056604		
South Central	Richmond Subarea3	0.1%	1%	-15%	-6.69	974	11	44.96153846	38.26923077		
Downtown	South of Market	0.1%	0%	-16%	-3.65	44813	11	22.18181818	18.52739726		
Northeast	SF screenline east	0.1%	0%	-17%	-4.86	10398	11	27.91071429	23.05405405		
Central	Outer Sunset	0.1%	0%	-18%	-5.57	2870	11	31.78846154	26.21568627		
Mission	Ingleside	0.1%	0%	-20%	-6.56	5038	11	33.16037736	26.6		
Northeast	Richmond Subarea2	0.1%	1%	-20%	-7.71	1757	11	38.69642857	30.98979592		
Central	Richmond Subarea2	0.1%	2%	-22%	-8.68	549	11	38.65384615	29.97169811		
Central	Presidio	0.1%	2%	-23%	-9.47	594	11	40.66666667	31.19298246		
South of Market	Richmond LandsEnd	0.1%	9%			125	11	49.20967742			
Presidio	Buena Vista	0.1%	2%	+26%	+6.95	483	10	26.66666667	33.62068966		
Richmond Subarea2	Northeast	0.1%	1%	-7%	-2.34	1778	10	33.7	31.36363636		
Northeast	Ingleside	0.1%	0%	-8%	-4.08	2891	10	48.87066246	44.78985507		
Northeast	Marina	0.1%	0%	-9%	-1.72	13591	10	19.27941176	17.55813953		
SF screenline north	Marina	0.1%	0%	-9%	-1.31	4907	10	14.01086957	12.69847328		
South Bayshore	South Bayshore	0.1%	0%	-11%	-1.60	24947	10	14.95	13.35263158		
Ingleside	Mission	0.1%	0%	-13%	-4.41	5126	10	33.44545455	29.03947368		
Northeast	Northeast	0.1%	0%	-13%	-2.51	48096	10	19.03521127	16.52380952		
Golden Gate Park	Bernal Heights	0.1%	8%			121	10	35.54123711			
SF screenline east	Mission	0.1%	0%	-24%	-5.79	7225	10	24.12222222	18.33333333		
Buena Vista	Richmond LandsEnd	0.1%	11%			95	10				
Presidio	South of Market	0.1%	1%	+5%	+2.48	791	9	46.14	48.61580882		
SF screenline north	Outer Sunset	0.1%	0%	+1%	+0.26	2034	9	23.44354839	23.70652174		
Presidio	North of Inner Sunset	0.1%	3%	-0%	-0.01	348	9	31.25925926	31.25263158		
North of Inner Sunset	Richmond Subarea4	0.1%	1%	-0%	-0.02	823	9	22.41176471	22.3902439		
Outer Sunset	Marina	0.1%	1%	-5%	-1.54	1782	9	33.77173913	32.23043478		
Richmond Subarea1	Bernal Heights	0.1%	7%	-0%	-0.19	138	9	49.03306343	48.84162521		
Richmond LandsEnd	Western Addition	0.1%	3%	-3%	-0.90	318	9	34.91666667	34.01492537		
Presidio	Northeast	0.1%	0%	-6%	-1.89	2133	9	31.2	29.30882353		
Richmond Subarea1	Presidio	0.1%	1%	+10%	+2.06	867	9	20.73529412	22.79268293		
Richmond Subarea3	Richmond Subarea2	0.1%	0%	-13%	-1.99	4128	9	15.1097561	13.11956522		
Richmond Subarea4	Western Addition	0.1%	0%	-14%	-2.15	5902	9	15.39333333	13.24157303		
Central	SF screenline east	0.1%	0%	-7%	-2.69	2308	9	37.62121212	34.93055556		

Origin Zone Name	Destination Zone Name	Percent of OD		Travel Time Change (%)	Travel Time Change (mins)	Fall 2019 Total Volume	Fall 2019 Volume Via JFK	Fall 2019 Median Travel Time (mins)	Fall 2021 Median Travel Time (mins)
		% of Total Volume on JFK	Percent of OD Volume Using JFK						
Western Addition	Mission	0.1%	0%	-8%	-2.05	8935	9	25.55	23.5
Bernal Heights	SF screenline north	0.1%	3%	-9%	-3.69	282	9	40.13953488	36.45238095
Buena Vista	South Central	0.1%	1%	-9%	-3.19	1292	9	34.34482759	31.15714286
Northeast	Central	0.1%	0%	-9%	-4.04	1937	9	42.61538462	38.57228916
Northeast	South of Market	0.1%	0%	-11%	-3.40	15787	9	30.29245283	26.8968254
Marina	Western Addition	0.1%	0%	-13%	-2.48	10729	9	19.67105263	17.18686869
Northeast	Western Addition	0.1%	0%	-15%	-4.18	9874	9	28	23.8164557
Presidio	Western Addition	0.1%	1%	-15%	-3.78	1405	9	24.81481481	21.03571429
Mission	South of Market	0.1%	0%	-18%	-3.89	18567	9	22.06451613	18.17647059
SF screenline east	Central	0.1%	0%	-24%	-7.57	2201	9	31.52105263	23.95508982
SF screenline east	Marina	0.1%	0%	-25%	-8.27	3138	9	32.47894737	24.21084337
SF screenline north	Richmond Subarea2	0.1%	1%	-29%	-3.90	1056	9	13.52654867	9.630653266
South of Market	Presidio	0.1%	1%	+6%	+2.41	712	8	41.5	43.91176471
SF screenline north	Ingleside	0.1%	0%	+3%	+0.94	1731	8	33.93518519	34.87096774
Buena Vista	Presidio	0.1%	2%	+2%	+0.59	472	8	27.51369863	28.10784314
South of Inner Sunset	Richmond Subarea4	0.1%	2%	-0%	-0.06	510	8	23.91538462	23.85135135
Central	North of Inner Sunset	0.1%	0%	-1%	-0.31	1680	8	21.77692308	21.46590909
Outer Sunset	Richmond Subarea4	0.1%	1%	-5%	-1.31	1573	8	28.58108108	27.27358491
Marina	South of Market	0.1%	0%	-5%	-2.05	5448	8	37.82692308	35.77692308
Richmond LandsEnd	Buena Vista	0.1%	10%			77	8		36.5
Richmond Subarea2	Ingleside	0.1%	0%	-7%	-2.23	2266	8	32.99056604	30.75925926
North of Inner Sunset	SF screenline south	0.1%	0%	-8%	-2.03	4512	8	26.28205128	24.25471698
Marina	Ingleside	0.1%	1%	-10%	-4.77	1511	8	48.25757576	43.4826087
Outer Sunset	Ingleside	0.1%	0%	-13%	-2.73	22417	8	21.00666667	18.28021978
Downtown	South of Inner Sunset	0.1%	1%	-13%	-5.27	1339	8	39.67391304	34.4010989
Ingleside	Downtown	0.1%	0%	-14%	-5.93	4025	8	43.34615385	37.41836735
South Bayshore	SF screenline east	0.1%	0%	-14%	-4.99	5991	8	34.65384615	29.65909091
South of Market	Central	0.1%	0%	-17%	-5.54	5124	8	31.875	26.33333333
North of Inner Sunset	Outer Sunset	0.1%	0%	-18%	-3.74	7404	8	20.51333333	16.77058824
Northeast	SF screenline north	0.1%	0%	-21%	-4.84	6460	8	23.56666667	18.725
South Bayshore	Presidio	0.1%	5%			162	8	49.26237624	
Bernal Heights	Richmond Subarea1	0.1%	4%			190	8	45.51408451	
South Central	Richmond Subarea2	0.0%	1%	+11%	+4.84	796	7	43.74444444	48.58429119
Western Addition	South Central	0.0%	0%	-3%	-1.23	4461	7	40.8902439	39.66129032
Central	Mission	0.0%	0%	-4%	-0.81	11080	7	19.62820513	18.81578947
Western Addition	Marina	0.0%	0%	-5%	-0.98	10546	7	18.41891892	17.43684211
South of Inner Sunset	Richmond Subarea3	0.0%	1%	-6%	-1.33	866	7	22.58433735	21.25862069
Richmond Subarea4	South of Inner Sunset	0.0%	1%	+8%	+2.21	621	7	28.72222222	30.93076923
Richmond Subarea4	Richmond Subarea3	0.0%	0%	-12%	-1.74	3541	7	14.00632911	12.26767677
Ingleside	Buena Vista	0.0%	0%	-9%	-3.06	1801	7	34.425	31.36206897
SF screenline north	Northeast	0.0%	0%	-9%	-2.44	5706	7	26.92424242	24.48
Downtown	Buena Vista	0.0%	0%	-10%	-2.57	6629	7	26.19491525	23.625

Origin Zone Name	Destination Zone Name	Percent of OD		Travel Time Change (%)	Travel Time Change (mins)	Fall 2019 Total Volume	Fall 2019 Volume Via JFK	Fall 2019 Median Travel Time (mins)	Fall 2021 Median Travel Time (mins)
		% of Total Volume on JFK	Volume Using JFK						
Buena Vista	Buena Vista	0.0%	0%	-11%	-1.68	7175	7	15.32352941	13.64393939
Outer Sunset	Presidio	0.0%	1%	-11%	-3.67	714	7	31.97619048	28.30582524
Northeast	Presidio	0.0%	0%	-15%	-4.38	2134	7	29.36567164	24.9875
South Central	Marina	0.0%	0%	-16%	-7.59	1402	7	46.62765957	39.03488372
South of Market	Marina	0.0%	0%	-19%	-6.75	5370	7	36.13636364	29.38888889
South Bayshore	Richmond Subarea4	0.0%	1%	-20%	-8.80	481	7	43.31651376	34.51538462
South Bayshore	South of Market	0.0%	0%	-21%	-5.68	10595	7	26.83333333	21.15217391
Presidio	Golden Gate Park	0.0%	2%	-5%	-1.11	282	7	24.60909091	23.5
Downtown	Richmond LandsEnd	0.0%	2%			366	7	48.53921569	
Presidio	South Bayshore	0.0%	5%	+0%	+0.14	119	6	49.18421053	49.32352941
Marina	South of Inner Sunset	0.0%	1%	-0%	-0.17	715	6	35.90540541	35.7375
SF screenline north	South Central	0.0%	1%	-1%	-0.54	696	6	43.22	42.67924528
South Central	SF screenline north	0.0%	1%	-2%	-0.67	845	6	42.5	41.83333333
Marina	Marina	0.0%	0%	-6%	-0.91	18154	6	14.23958333	13.33168317
South Central	Mission	0.0%	0%	-7%	-1.86	10273	6	27.54	25.67808219
North of Inner Sunset	Marina	0.0%	1%	-7%	-2.08	892	6	30.57792208	28.5
Richmond LandsEnd	South of Market	0.0%	6%			109	6	48.93074581	
Richmond Subarea3	SF screenline north	0.0%	0%	-13%	-1.47	1429	6	11.06349206	9.594339623
Richmond Subarea1	Richmond Subarea4	0.0%	0%	-12%	-2.75	1608	6	22.55172414	19.8030303
Richmond Subarea3	Marina	0.0%	0%	-12%	-2.77	1819	6	23.07142857	20.30327869
Richmond Subarea4	Richmond Subarea4	0.0%	0%	-12%	-1.69	2932	6	13.60227273	11.91489362
Buena Vista	Mission	0.0%	0%	-8%	-1.73	5056	6	21.04666667	19.31395349
Richmond Subarea2	Richmond Subarea2	0.0%	0%	-9%	-1.25	3378	6	13.14814815	11.9
Downtown	Mission	0.0%	0%	-9%	-2.23	16739	6	25.35714286	23.12295082
Downtown	Central	0.0%	0%	-11%	-3.43	5299	6	31.00909091	27.57692308
South of Inner Sunset	Northeast	0.0%	1%	-13%	-6.07	905	6	47.88461538	41.8125
SF screenline north	Richmond Subarea3	0.0%	1%	-13%	-1.83	1068	6	14.33333333	12.5
North of Inner Sunset	SF screenline north	0.0%	0%	-14%	-3.21	1607	6	22.51075269	19.29787234
SF screenline south	South Bayshore	0.0%	0%	-14%	-1.74	15749	6	12.14646465	10.40163934
Mission	South Central	0.0%	0%	-15%	-4.08	10312	6	28.00819672	23.92857143
SF screenline east	South Central	0.0%	0%	-15%	-4.21	3464	6	27.82989691	23.62380952
South of Inner Sunset	Downtown	0.0%	0%	-20%	-7.62	1389	6	37.48113208	29.86046512
SF screenline east	Ingleside	0.0%	0%	-31%	-10.88	3858	6	35.38235294	24.5
Golden Gate Park	Presidio	0.0%	2%	-11%	-2.54	309	6	23.56666667	21.02777778
Northeast	Richmond LandsEnd	0.0%	3%			233	6	37.42792793	
Ingleside	Richmond Subarea2	0.0%	0%	+6%	+1.78	2223	5	31.68055556	33.46296296
South Central	SF screenline south	0.0%	0%	+3%	+0.23	37217	5	6.81372549	7.045454545
Buena Vista	Downtown	0.0%	0%	+2%	+0.46	6288	5	25.48305085	25.94285714
Buena Vista	Marina	0.0%	0%	+2%	+0.39	1692	5	25.12195122	25.51470588
Buena Vista	Western Addition	0.0%	0%	-2%	-0.28	6878	5	16.8875	16.60344828
Marina	Richmond Subarea3	0.0%	0%	-4%	-0.88	2015	5	22.70967742	21.83009709
Outer Sunset	Richmond Subarea3	0.0%	0%	-4%	-0.96	2886	5	23.85526316	22.89622642







Origin Zone Name	Destination Zone Name	% of Total		Percent of OD		Travel Time		Fall 2019 Total Volume	Fall 2019 Volume Via JFK	Fall 2019 Median Travel Time (mins)	Fall 2021 Median Travel Time (mins)
		Volume on JFK	Volume Using JFK	Travel Time Change (%)	Change (mins)						
Buena Vista	SF screenline east	0.0%	0%	-6%	-1.90	1958	5	33.09090909	31.19387755		
Central	Central	0.0%	0%	-7%	-0.93	18554	5	14.23076923	13.29807692		
Western Addition	South of Market	0.0%	0%	-7%	-2.09	9624	5	31.57142857	29.48484848		
Buena Vista	South of Inner Sunset	0.0%	0%	-8%	-1.63	1173	5	21.5125	19.87804878		
Richmond LandsEnd	Northeast	0.0%	3%	-8%	-3.40	170	5	43.36666667	39.96428571		
Richmond Subarea1	South Central	0.0%	1%	-8%	-3.69	872	5	46.72807018	43.03658537		
Ingleside	Richmond Subarea3	0.0%	0%	-9%	-3.06	2349	5	33.66901408	30.60588235		
Richmond Subarea2	Marina	0.0%	0%	-13%	-3.09	1525	5	22.98529412	19.89240506		
Richmond Subarea1	Northeast	0.0%	0%	-12%	-5.02	2189	5	43.01219512	37.99333333		
Richmond Subarea4	Northeast	0.0%	0%	-9%	-2.45	2195	5	26.22307692	23.77777778		
Richmond Subarea3	Richmond Subarea4	0.0%	0%	-16%	-2.52	3104	5	15.40225564	12.88095238		
Richmond Subarea4	Downtown	0.0%	0%	-1%	-0.20	3662	5	27.99152542	27.78888889		
Richmond Subarea1	Outer Sunset	0.0%	0%	+9%	+1.92	4790	5	20.45890411	22.37640449		
Northeast	Richmond Subarea4	0.0%	0%	-10%	-2.66	2257	5	26.26811594	23.60377358		
Richmond Subarea1	Richmond Subarea1	0.0%	0%	-4%	-0.61	7376	5	13.60204082	12.9950495		
SF screenline south	South of Inner Sunset	0.0%	0%	-13%	-2.09	5056	5	16.54901961	14.45882353		
Downtown	South Central	0.0%	0%	-13%	-4.89	8538	5	37.77586207	32.88095238		
South Bayshore	Northeast	0.0%	0%	-16%	-6.97	3365	5	44.23913043	37.27083333		
North of Inner Sunset	Richmond Subarea2	0.0%	0%	-20%	-4.14	1022	5	20.53658537	16.39726027		
South of Market	South Central	0.0%	0%	-20%	-5.84	7867	5	28.92307692	23.08666667		
Bernal Heights	Downtown	0.0%	0%	-21%	-7.50	2102	5	35.98863636	28.48901099		
South of Market	South of Inner Sunset	0.0%	0%	-21%	-7.88	1326	5	37.69607843	29.81818182		
North of Inner Sunset	Mission	0.0%	0%	-22%	-6.64	1758	5	30.77906977	24.14084507		
South Central	South of Market	0.0%	0%	-23%	-7.34	8442	5	31.36956522	24.02857143		
Mission	Richmond Subarea4	0.0%	0%	+13%	+4.20	1050	4	31.42957746	35.63333333		
Presidio	Outer Sunset	0.0%	1%	+2%	+0.50	619	4	30.10344828	30.59859155		
North of Inner Sunset	Ingleside	0.0%	0%	-0%	-0.12	3765	4	25.68571429	25.56451613		
Buena Vista	Richmond Subarea4	0.0%	0%	-4%	-0.78	1286	4	20.83846154	20.0625		
South of Inner Sunset	Marina	0.0%	0%	-5%	-1.87	876	4	34.79090909	32.92045455		
Central	Ingleside	0.0%	0%	-5%	-1.30	5632	4	24.1031746	22.8		
Outer Sunset	Richmond Subarea1	0.0%	0%	-8%	-1.47	4976	4	18.875	17.40196078		
SF screenline south	Presidio	0.0%	0%	-8%	-3.13	1239	4	38.31188119	35.17857143		
South of Inner Sunset	SF screenline east	0.0%	0%	-8%	-3.67	813	4	44.74	41.06818182		
Ingleside	Ingleside	0.0%	0%	-9%	-1.38	57667	4	15.57142857	14.18888889		
Ingleside	Northeast	0.0%	0%	-9%	-4.41	2837	4	48.75684932	44.34313725		
Marina	Buena Vista	0.0%	0%	-9%	-2.44	1769	4	26.89772727	24.46		
Richmond LandsEnd	Downtown	0.0%	1%	-23%	-10.73	349	4	47.21666667	36.48601399		
Central	Buena Vista	0.0%	0%	-11%	-1.95	5088	4	18.078125	16.12765957		
South Central	South Central	0.0%	0%	-11%	-1.64	48751	4	14.97826087	13.34042553		
Richmond Subarea1	South of Inner Sunset	0.0%	1%	-12%	-3.59	766	4	30.97619048	27.38888889		
Richmond Subarea4	South Central	0.0%	0%	-0%	-0.07	858	4	48.17241379	48.10606061		
South Central	SF screenline east	0.0%	0%	-11%	-4.09	3772	4	35.80588235	31.71428571		

Origin Zone Name	Destination Zone Name	% of Total		Percent of OD		Travel Time		Fall 2019 Total Volume	Fall 2019 Volume Via JFK	Fall 2019 Median Travel Time (mins)	Fall 2021 Median Travel Time (mins)
		Volume on JFK	Volume Using JFK	Travel Time Change (%)	Change (mins)						
Western Addition	Richmond Subarea4	0.0%	0%		-11%	-1.78	5829	4	15.48901099	13.70879121	
Richmond Subarea4	SF screenline east	0.0%	0%		-18%	-7.55	967	4	42.83333333	35.28313253	
Richmond Subarea1	Richmond Subarea3	0.0%	0%		-4%	-0.84	3070	4	19.15853659	18.31609195	
Richmond Subarea3	Richmond Subarea1	0.0%	0%		-7%	-1.30	3396	4	18.05670103	16.76086957	
Richmond Subarea2	Outer Sunset	0.0%	0%		-10%	-2.36	3457	4	23.3	20.9375	
South Bayshore	Ingleside	0.0%	0%		-12%	-3.54	5197	4	29.14912281	25.61392405	
Richmond Subarea2	Richmond Subarea3	0.0%	0%		-10%	-1.50	4235	4	14.6547619	13.15789474	
Mission	Central	0.0%	0%		-12%	-2.36	10984	4	19.3	16.94086022	
South of Inner Sunset	Outer Sunset	0.0%	0%		-12%	-2.23	11448	4	18.01136364	15.78440367	
Richmond Subarea1	Richmond Subarea2	0.0%	0%		-15%	-2.31	4542	4	15.57865169	13.27083333	
Richmond Subarea2	Richmond Subarea1	0.0%	0%		-6%	-0.91	4882	4	14.4223301	13.51030928	
Bernal Heights	Outer Sunset	0.0%	1%		-14%	-4.82	707	4	35.15441176	30.33802817	
Central	SF screenline south	0.0%	0%		-14%	-2.28	6980	4	16.38607595	14.10377358	
South Central	Northeast	0.0%	0%		-15%	-7.22	5634	4	48.7444062	41.52380952	
Golden Gate Park	Richmond LandsEnd	0.0%	2%				221	4	23.83823529		
Buena Vista	Bernal Heights	0.0%	0%		+3%	+0.75	724	3	28.08730159	28.83333333	
Presidio	SF screenline east	0.0%	1%		+3%	+1.21	501	3	45.51587302	46.72222222	
Presidio	Ingleside	0.0%	1%		+2%	+0.94	585	3	40.58108108	41.52469136	
Presidio	SF screenline south	0.0%	0%		+0%	+0.14	1195	3	37.79824561	37.94186047	
South of Inner Sunset	Mission	0.0%	0%		-0%	-0.04	1320	3	28.56060606	28.52469136	
North of Inner Sunset	North of Inner Sunset	0.0%	0%		-2%	-0.22	6518	3	14.49038462	14.27142857	
Marina	Richmond Subarea2	0.0%	0%		-3%	-0.61	1498	3	21.85555556	21.24683544	
Presidio	Marina	0.0%	0%		-4%	-0.79	3740	3	17.80136986	17.015625	
South of Inner Sunset	Buena Vista	0.0%	0%		-5%	-1.16	1139	3	23.62280702	22.45833333	
Mission	Bernal Heights	0.0%	0%		-5%	-0.91	6716	3	18.39873418	17.48701299	
Central	South Bayshore	0.0%	0%		-5%	-1.57	2378	3	29.7962963	28.22222222	
Western Addition	Bernal Heights	0.0%	0%		-6%	-2.01	1476	3	35.19090909	33.18269231	
South of Market	Northeast	0.0%	0%		-10%	-2.65	16007	3	27.5	24.84615385	
Ingleside	South Bayshore	0.0%	0%		-10%	-2.93	5303	3	30.00909091	27.07692308	
Central	South of Inner Sunset	0.0%	0%		-12%	-2.24	2685	3	18.31927711	16.07831325	
Richmond LandsEnd	Central	0.0%	2%				128	3	45.9		
Richmond Subarea2	South of Inner Sunset	0.0%	1%		-3%	-0.83	577	3	26.42307692	25.5952381	
Ingleside	Outer Sunset	0.0%	0%		-13%	-2.70	22123	3	20.93283582	18.23493976	
Richmond Subarea4	Central	0.0%	0%		+7%	+2.01	946	3	29.30392157	31.31481481	
Richmond Subarea4	Mission	0.0%	0%		-5%	-1.72	1060	3	36.51724138	34.80188679	
Richmond Subarea1	SF screenline north	0.0%	0%		-13%	-1.80	1280	3	14.17326733	12.37790698	
Richmond Subarea4	Richmond Subarea1	0.0%	0%		-2%	-0.39	1759	3	22.48863636	22.1036036	
Ingleside	Marina	0.0%	0%		-14%	-6.41	1438	3	45.75806452	39.35227273	
South Bayshore	North of Inner Sunset	0.0%	0%		-15%	-5.97	659	3	39.8030303	33.82954545	
Marina	Northeast	0.0%	0%		-15%	-3.20	13495	3	21.04411765	17.84328358	
Mission	South of Inner Sunset	0.0%	0%		-18%	-5.23	1416	3	29.35483871	24.12337662	
Presidio	SF screenline north	0.0%	0%		-20%	-1.86	2823	3	9.418918919	7.555555556	

Origin Zone Name	Destination Zone Name	% of Total		Percent of OD		Travel Time		Fall 2019 Total Volume	Fall 2019 Volume Via JFK	Fall 2019 Median Travel Time (mins)	Fall 2021 Median Travel Time (mins)
		Volume on JFK	Volume Using JFK	Travel Time Change (%)	Change (mins)						
South Central	Buena Vista	0.0%	0%		-21%	-7.42	1335	3	35.95588235	28.53488372	
South of Market	Richmond Subarea4	0.0%	0%		-22%	-8.54	1529	3	38.05555556	29.51282051	
Bernal Heights	Richmond Subarea2	0.0%	3%				108	3		42.04444444	
North of Inner Sunset	Richmond LandsEnd	0.0%	2%				125	3			
Central	Richmond LandsEnd	0.0%	2%				130	3			
South Central	Richmond Subarea4	0.0%	0%				852	3	44.2		
North of Inner Sunset	Presidio	0.0%	1%		+33%	+8.91	319	2	26.87333333	35.77941176	
Central	Richmond Subarea4	0.0%	0%		+9%	+2.34	1038	2	26.34962406	28.69387755	
South Bayshore	Bernal Heights	0.0%	0%		+8%	+1.37	2942	2	17.31052632	18.67647059	
SF screenline north	South of Inner Sunset	0.0%	0%		+1%	+0.41	483	2	27.86507937	28.27777778	
Bernal Heights	South of Market	0.0%	0%		-2%	-0.63	3269	2	25.66666667	25.03731343	
South of Inner Sunset	SF screenline south	0.0%	0%		-3%	-0.57	5341	2	17.5	16.93333333	
Outer Sunset	South Bayshore	0.0%	0%		-3%	-1.47	2204	2	42.33823529	40.86363636	
North of Inner Sunset	South Central	0.0%	0%		-7%	-2.36	1637	2	34.06	31.6971831	
Western Addition	South Bayshore	0.0%	0%		-7%	-2.60	2558	2	37.38	34.77777778	
North of Inner Sunset	Central	0.0%	0%		-8%	-1.88	1614	2	22.84375	20.96551724	
South Bayshore	South Central	0.0%	0%		-8%	-1.65	11612	2	20.02	18.36746988	
Presidio	Downtown	0.0%	0%		-10%	-3.98	1498	2	40.82631579	36.84246575	
Ingleside	Presidio	0.0%	0%		-10%	-4.53	541	2	44.39583333	39.86206897	
Richmond LandsEnd	Richmond Subarea3	0.0%	1%		-23%	-6.52	196	2	28.57017544	22.04761905	
South of Inner Sunset	South of Market	0.0%	0%		-14%	-5.78	1413	2	41.4137931	35.63432836	
Richmond LandsEnd	Richmond Subarea1	0.0%	0%		-13%	-2.18	827	2	16.26699029	14.0840708	
Richmond Subarea1	Marina	0.0%	0%		+10%	+2.74	1318	2	27.23684211	29.97222222	
Bernal Heights	SF screenline east	0.0%	0%		-15%	-5.45	1176	2	36.60958904	31.16304348	
SF screenline north	Presidio	0.0%	0%		-15%	-1.64	2555	2	10.83333333	9.194214876	
South Central	Downtown	0.0%	0%		-20%	-8.41	8567	2	42.57142857	34.16037736	
Marina	SF screenline north	0.0%	0%		-22%	-3.08	5678	2	13.94318182	10.86153846	
South Bayshore	Richmond LandsEnd	0.0%	3%				76	2			
Ingleside	North of Inner Sunset	0.0%	0%		+6%	+1.44	4066	1	22.79761905	24.23611111	
Outer Sunset	South Central	0.0%	0%		+3%	+1.03	5121	1	33.03731343	34.06756757	
Ingleside	SF screenline north	0.0%	0%		+3%	+0.89	2064	1	29.77272727	30.65789474	
Buena Vista	South of Market	0.0%	0%		+1%	+0.25	3739	1	28.03030303	28.27777778	
South of Inner Sunset	South Central	0.0%	0%		+0%	+0.10	2980	1	27.47560976	27.57407407	
Central	South Central	0.0%	0%		-2%	-0.46	4572	1	23.44202899	22.97761194	
South of Inner Sunset	Central	0.0%	0%		-2%	-0.40	2815	1	17.54054054	17.1372549	
South Bayshore	South of Inner Sunset	0.0%	0%		-6%	-1.95	854	1	32.76785714	30.81851852	
South of Inner Sunset	Richmond Subarea2	0.0%	0%		-6%	-1.45	538	1	22.98333333	21.53597122	
Ingleside	South Central	0.0%	0%		-9%	-1.99	21117	1	22.28125	20.29268293	
Bernal Heights	SF screenline south	0.0%	0%		-11%	-1.27	4492	1	11.15957447	9.885321101	
Bernal Heights	Northeast	0.0%	0%		-11%	-5.05	924	1	44.1	39.04736842	
South Central	Outer Sunset	0.0%	0%		-12%	-4.13	4863	1	35.07894737	30.95205479	
Downtown	Bernal Heights	0.0%	0%		-12%	-4.14	2016	1	35.11016949	30.96835443	

Origin Zone Name	Destination Zone Name	% of Total		Percent of OD		Travel Time		Fall 2019 Total Volume	Fall 2019 Volume Via JFK	Fall 2019 Median Travel Time (mins)	Fall 2021 Median Travel Time (mins)
		Volume on JFK	Volume Using JFK	Travel Time Change (%)	Change (mins)						
South Central	Central	0.0%	0%		-12%	-2.70	4841	1	22.04411765	19.34444444	
Buena Vista	Central	0.0%	0%		-13%	-2.31	5647	1	18.17816092	15.86842105	
SF screenline south	South Central	0.0%	0%		-15%	-1.09	34910	1	7.40070922	6.312030075	
Ingleside	Richmond Subarea1	0.0%	0%		-15%	-5.31	3163	1	35.68518519	30.37272727	
Outer Sunset	South of Inner Sunset	0.0%	0%		-15%	-2.65	11115	1	17.52777778	14.8814433	
Downtown	South Bayshore	0.0%	0%		-15%	-5.71	5931	1	37.6875	31.97826087	
Richmond LandsEnd	South Bayshore	0.0%	2%				65	1			
Richmond Subarea4	South Bayshore	0.0%	0%		+7%	+2.66	490	1	40.4	43.05555556	
Richmond LandsEnd	Outer Sunset	0.0%	0%		-13%	-3.26	625	1	25.4245283	22.16666667	
Richmond Subarea2	SF screenline north	0.0%	0%		-21%	-2.42	1252	1	11.58333333	9.159259259	
Buena Vista	Northeast	0.0%	0%		-19%	-6.48	1858	1	34.86842105	28.38732394	
Bernal Heights	Bernal Heights	0.0%	0%		-19%	-2.36	4004	1	12.3556701	10	
Presidio	Richmond Subarea3	0.0%	0%		-19%	-3.98	967	1	20.72641509	16.75	
Richmond Subarea2	Richmond Subarea4	0.0%	0%		-11%	-1.82	1700	1	16.41666667	14.59322034	
Richmond Subarea4	Richmond Subarea2	0.0%	0%		-16%	-3.02	2003	1	18.375	15.35217391	
South of Market	Bernal Heights	0.0%	0%		-21%	-5.58	2899	1	26.16101695	20.58510638	
Richmond Subarea3	Outer Sunset	0.0%	0%		-10%	-2.67	3208	1	26.81168831	24.14	
Presidio	South Central	0.0%	1%				192	1	49.00578035		
Bernal Heights	Buena Vista	0.0%	0%				646	1	27.25		
Northeast	Bernal Heights	0.0%	0%		+14%	+5.50	733	0	40.2	45.69642857	
South of Inner Sunset	Bernal Heights	0.0%	0%		+9%	+2.65	528	0	28.62244898	31.2755102	
Bernal Heights	North of Inner Sunset	0.0%	0%		+8%	+2.00	452	0	26	28	
South of Inner Sunset	Presidio	0.0%	0%		+7%	+2.26	261	0	30.9084507	33.16666667	
Presidio	Richmond Subarea2	0.0%	0%		+6%	+1.01	859	0	16.92647059	17.93421053	
Marina	South Bayshore	0.0%	0%		+3%	+1.18	1096	0	45.70289855	46.88095238	
Buena Vista	South Bayshore	0.0%	0%		+2%	+0.63	1068	0	35	35.63333333	
Central	Marina	0.0%	0%		+0%	+0.04	1532	0	32.22368421	32.26744186	
South Bayshore	Buena Vista	0.0%	0%		-2%	-0.56	992	0	35.87634409	35.3203125	
Presidio	Richmond Subarea1	0.0%	0%		-2%	-0.33	866	0	20.66455696	20.33486239	
Presidio	Richmond Subarea4	0.0%	0%		-2%	-0.37	1223	0	16.9537037	16.58536585	
South of Inner Sunset	Richmond Subarea1	0.0%	0%		-2%	-0.71	758	0	29.70967742	29	
Marina	South Central	0.0%	0%		-3%	-1.34	1313	0	48.74061433	47.40540541	
Ingleside	Central	0.0%	0%		-4%	-0.98	5589	0	23.98529412	23.00847458	
South Bayshore	Mission	0.0%	0%		-5%	-1.11	8182	0	23.90350877	22.79310345	
South Central	Ingleside	0.0%	0%		-5%	-0.99	21014	0	20.76666667	19.77631579	
Central	South of Market	0.0%	0%		-6%	-1.87	5036	0	30.85294118	28.98611111	
South of Inner Sunset	Ingleside	0.0%	0%		-6%	-1.13	14492	0	18.1627907	17.03246753	
South of Inner Sunset	South Bayshore	0.0%	0%		-7%	-2.72	884	0	39.03488372	36.31355932	
Outer Sunset	Richmond Subarea2	0.0%	0%		-7%	-1.63	2737	0	23.08974359	21.45833333	
South of Inner Sunset	South of Inner Sunset	0.0%	0%		-8%	-0.95	8628	0	12.625	11.67592593	
Bernal Heights	South of Inner Sunset	0.0%	0%		-8%	-1.92	579	0	25.43203883	23.508	
SF screenline south	Richmond LandsEnd	0.0%	0%		-8%	-2.07	863	0	27.25903614	25.19230769	

Origin Zone Name	Destination Zone Name	% of Total		Percent of OD		Travel Time		Fall 2019 Total Volume	Fall 2019 Volume Via JFK	Fall 2019 Median Travel Time (mins)	Fall 2021 Median Travel Time (mins)
		Volume on JFK	Volume Using JFK	Travel Time Change (%)	Change (mins)						
South Central	Bernal Heights	0.0%	0%	-8%	-1.46	4005	0	17.65789474	16.20175439		
South Bayshore	Central	0.0%	0%	-8%	-2.39	2506	0	28.328125	25.94274809		
Marina	Mission	0.0%	0%	-9%	-3.10	3306	0	35.56382979	32.46341463		
South Central	South Bayshore	0.0%	0%	-9%	-1.76	12417	0	18.59375	16.83802817		
Presidio	Bernal Heights	0.0%	0%	-9%	-4.65	123	0	48.93260188	44.28632479		
South Central	North of Inner Sunset	0.0%	0%	-10%	-3.01	1698	0	31.7027027	28.68888889		
Central	Northeast	0.0%	0%	-10%	-3.87	1772	0	40.25641026	36.38888889		
South of Inner Sunset	SF screenline north	0.0%	0%	-10%	-2.50	684	0	25.2654321	22.76666667		
Presidio	Presidio	0.0%	0%	-10%	-1.58	4614	0	15.08510638	13.50869565		
South of Inner Sunset	North of Inner Sunset	0.0%	0%	-11%	-1.59	3341	0	15.1557377	13.56315789		
SF screenline north	Richmond Subarea4	0.0%	0%	-11%	-1.73	1824	0	16.02447552	14.29166667		
Bernal Heights	Western Addition	0.0%	0%	-12%	-3.82	1413	0	32.73076923	28.91538462		
Marina	Bernal Heights	0.0%	0%	-12%	-5.30	449	0	45.07692308	39.77941176		
Central	Bernal Heights	0.0%	0%	-12%	-2.36	3041	0	19.93421053	17.57446809		
South of Market	South Bayshore	0.0%	0%	-12%	-3.02	9386	0	25.25757576	22.23913043		
Northeast	Buena Vista	0.0%	0%	-12%	-4.25	1972	0	34.88709677	30.64		
South Central	South of Inner Sunset	0.0%	0%	-13%	-3.45	2995	0	26.70408163	23.25862069		
Outer Sunset	SF screenline north	0.0%	0%	-14%	-3.33	2152	0	24.06962025	20.73611111		
Bernal Heights	Ingleside	0.0%	0%	-14%	-3.11	2355	0	22.453125	19.33870968		
Ingleside	Bernal Heights	0.0%	0%	-14%	-3.34	2326	0	23.66176471	20.3245614		
SF screenline east	South of Inner Sunset	0.0%	0%	-14%	-5.57	866	0	38.8220339	33.24736842		
Northeast	South Central	0.0%	0%	-14%	-7.05	5262	0	48.66094033	41.61428571		
North of Inner Sunset	South of Inner Sunset	0.0%	0%	-15%	-2.31	2986	0	15.91176471	13.60204082		
Bernal Heights	Central	0.0%	0%	-15%	-2.65	3000	0	17.62162162	14.96774194		
Northeast	South Bayshore	0.0%	0%	-15%	-7.00	3212	0	45.77906977	38.77777778		
SF screenline north	Richmond LandsEnd	0.0%	0%	-15%	-2.98	536	0	19.29738562	16.31642512		
Marina	Presidio	0.0%	0%	-17%	-2.79	3817	0	16.76829268	13.98101266		
North of Inner Sunset	South Bayshore	0.0%	0%	-17%	-7.02	651	0	41.80434783	34.78688525		
Ingleside	South of Inner Sunset	0.0%	0%	-17%	-3.20	14232	0	18.5	15.3		
Marina	Richmond Subarea4	0.0%	0%	-17%	-3.01	3860	0	17.2972973	14.28723404		
Bernal Heights	South Bayshore	0.0%	0%	-18%	-3.43	3179	0	19.20588235	15.7755102		
SF screenline north	Richmond Subarea1	0.0%	0%	-18%	-2.91	1085	0	16.25268817	13.33969466		
Bernal Heights	South Central	0.0%	0%	-18%	-3.40	4309	0	18.75333333	15.3556701		
Bernal Heights	Mission	0.0%	0%	-18%	-3.27	6385	0	17.71538462	14.44117647		
Downtown	Richmond Subarea4	0.0%	0%	-22%	-6.67	3380	0	30.30701754	23.63636364		
Ingleside	Richmond LandsEnd	0.0%	0%	-22%	-7.10	285	0	32.01851852	24.92105263		
North of Inner Sunset	Bernal Heights	0.0%	0%	-23%	-8.72	349	0	38.61363636	29.89473684		
SF screenline east	South Bayshore	0.0%	0%	-23%	-5.68	5852	0	24.9368932	19.26033058		
Richmond LandsEnd	South of Inner Sunset	0.0%	0%	+26%	+7.48	107	0	28.46551724	35.94210526		
Outer Sunset	Bernal Heights	0.0%	0%	-25%	-9.71	662	0	39.41071429	29.7027972		
South Bayshore	Marina	0.0%	0%	-25%	-11.61	1112	0	45.85	34.23880597		
Richmond Subarea3	Presidio	0.0%	0%	+10%	+1.80	900	0	17.15333333	18.95		

Origin Zone Name	Destination Zone Name	% of Total		Percent of OD		Travel Time		Fall 2019 Total Volume	Fall 2019 Volume Via JFK	Fall 2019 Median Travel Time (mins)	Fall 2021 Median Travel Time (mins)
		Volume on JFK	Volume Using JFK	Travel Time Change (%)	Change (mins)						
SF screenline south	Bernal Heights	0.0%	0%		-29%	-3.45	4318	0	11.74761905	8.295454545	
SF screenline east	Bernal Heights	0.0%	0%		-34%	-9.59	1044	0	28.43506494	18.84285714	
Richmond Subarea4	Presidio	0.0%	0%		+7%	+1.00	1146	0	15.14705882	16.14705882	
Richmond Subarea1	Richmond LandsEnd	0.0%	0%		+6%	+0.97	727	0	16.06589147	17.04054054	
Richmond LandsEnd	SF screenline south	0.0%	0%		-2%	-0.53	839	0	28.4245283	27.89344262	
Richmond LandsEnd	Richmond LandsEnd	0.0%	0%		-3%	-0.56	342	0	16.28021978	15.72222222	
Richmond Subarea4	South of Market	0.0%	0%		-4%	-1.46	1735	0	38.89215686	37.43421053	
Richmond LandsEnd	SF screenline north	0.0%	0%		-5%	-0.93	477	0	19.69444444	18.76923077	
Richmond Subarea2	Presidio	0.0%	0%		-6%	-1.05	845	0	18.225	17.17045455	
Richmond Subarea4	Marina	0.0%	0%		-11%	-1.87	3582	0	16.84246575	14.97311828	
Richmond Subarea4	SF screenline north	0.0%	0%		-21%	-3.03	1988	0	14.54444444	11.51648352	
Presidio	South of Inner Sunset	0.0%	0%				232	0	33.92857143		
Presidio	Richmond LandsEnd	0.0%	0%				169	0	22.0106383		
SF screenline north	SF screenline north	0.0%	0%				119787	0			
South of Inner Sunset	Richmond LandsEnd	0.0%	0%				121	0			
Richmond Subarea3	Richmond LandsEnd	0.0%	0%				243	0	21.93442623		
Richmond LandsEnd	Presidio	0.0%	0%				158	0	26.27192982		
Richmond LandsEnd	Ingleside	0.0%	0%				310	0	31.92222222		
Richmond LandsEnd	North of Inner Sunset	0.0%	0%				126	0	30.13478261		
Richmond LandsEnd	Richmond Subarea2	0.0%	0%				308	0	19.17878788		
Richmond LandsEnd	Richmond Subarea4	0.0%	0%				107	0	30.82231405		
Richmond LandsEnd	Marina	0.0%	0%				68	0			
Richmond LandsEnd	Bernal Heights	0.0%	0%				27	0			
Richmond LandsEnd	South Central	0.0%	0%				123	0	46.53773585		
SF screenline east	SF screenline east	0.0%	0%				235474	0			
Richmond Subarea2	Richmond LandsEnd	0.0%	0%				280	0	13.8537415		
Richmond Subarea4	Richmond LandsEnd	0.0%	0%				120	0			
Richmond Subarea4	Bernal Heights	0.0%	0%				180	0	44.56185567		
Marina	Richmond LandsEnd	0.0%	0%				128	0	34.87864078		
SF screenline south	SF screenline south	0.0%	0%				267502	0			
Outer Sunset	Richmond LandsEnd	0.0%	0%				631	0	20.02272727		
Bernal Heights	Presidio	0.0%	0%				158	0			
Bernal Heights	Richmond LandsEnd	0.0%	0%				17	0			
Bernal Heights	Richmond Subarea4	0.0%	0%				209	0	42.98507463		
Bernal Heights	Marina	0.0%	0%				534	0	45.625		
South Central	Presidio	0.0%	0%				192	0	48.93279173		
South Central	Richmond LandsEnd	0.0%	0%				134	0			

Appendix C: Key Corridor Volumes

Fall 2019

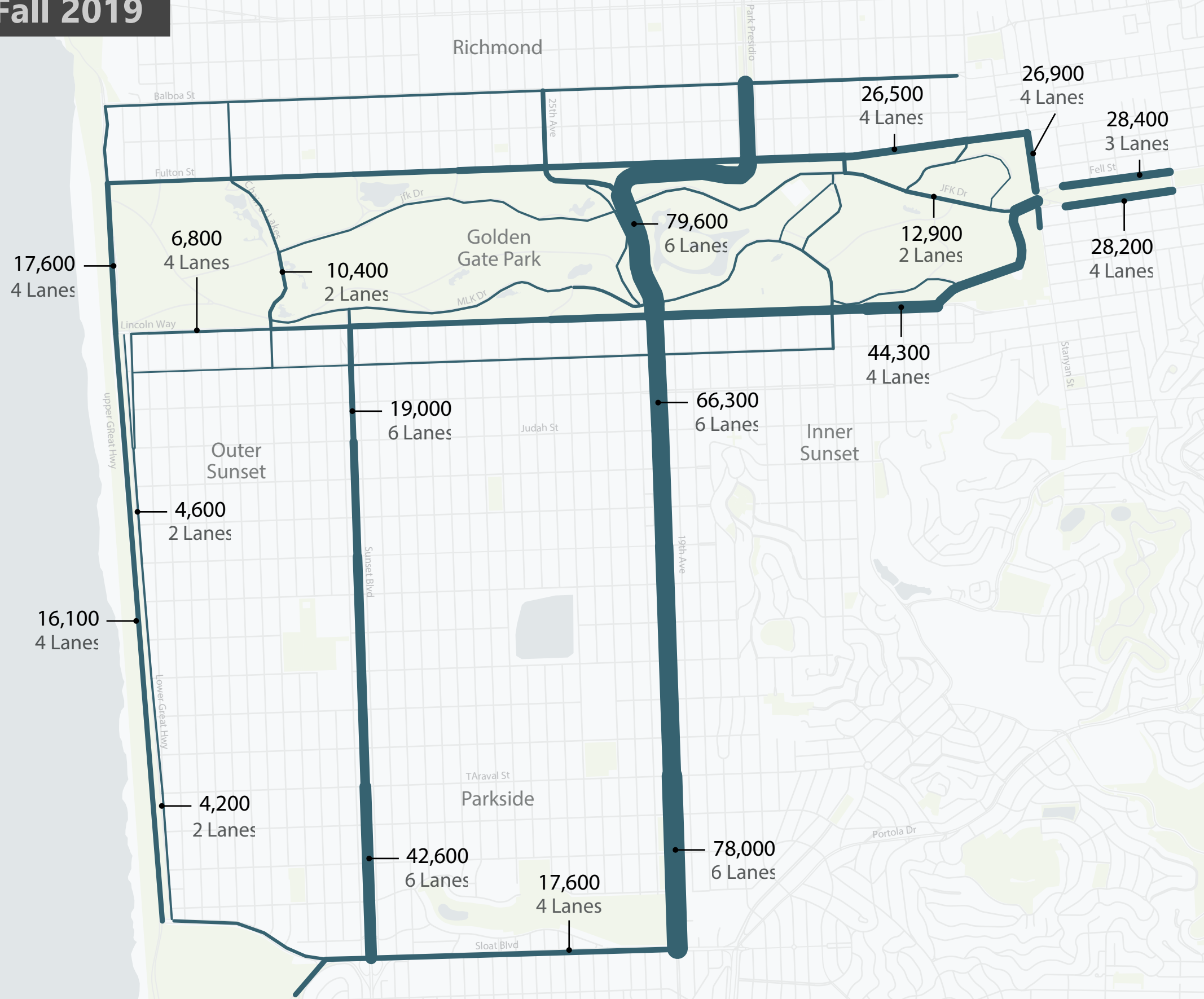

Fall 2021

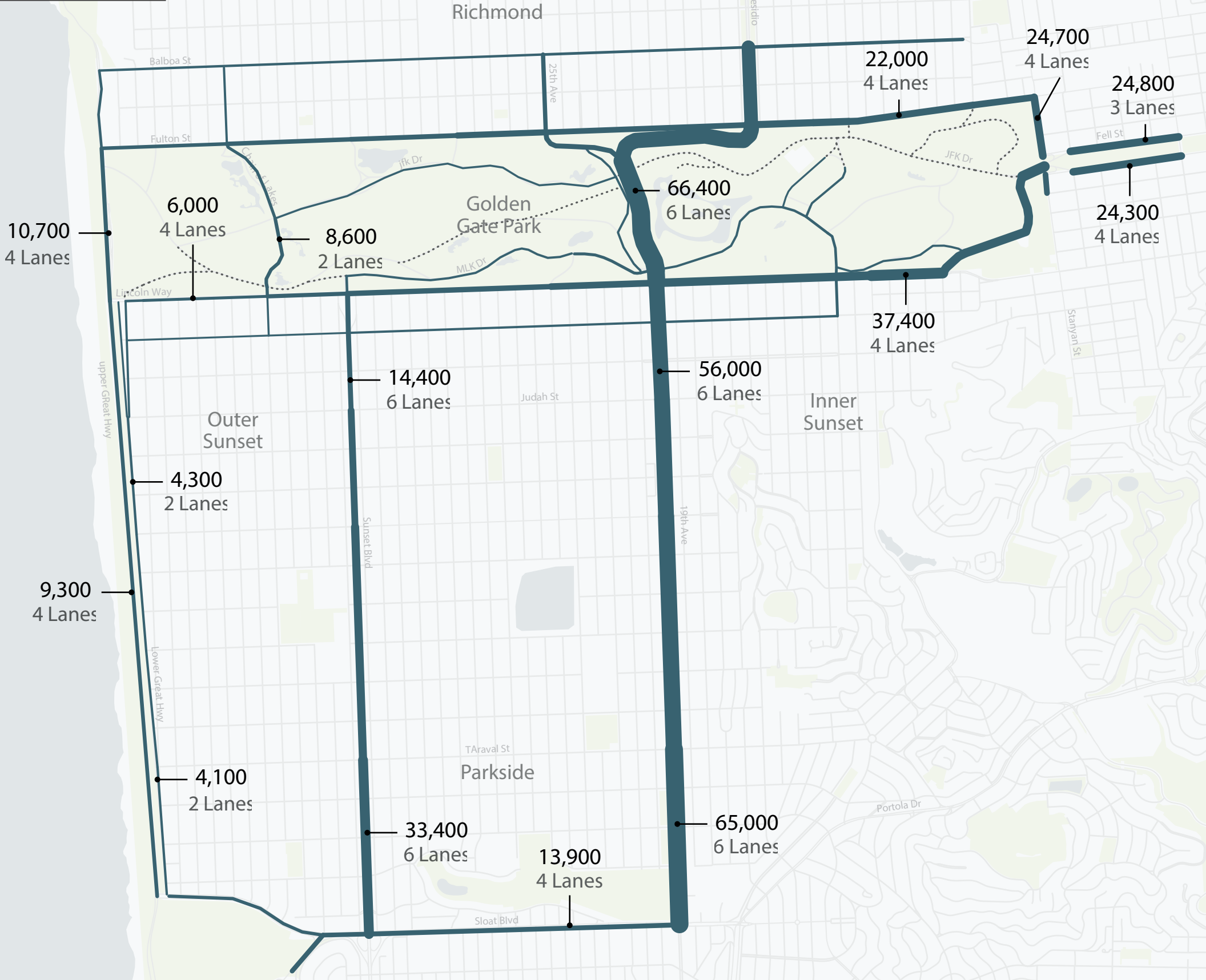

Change from 2019 to 2021

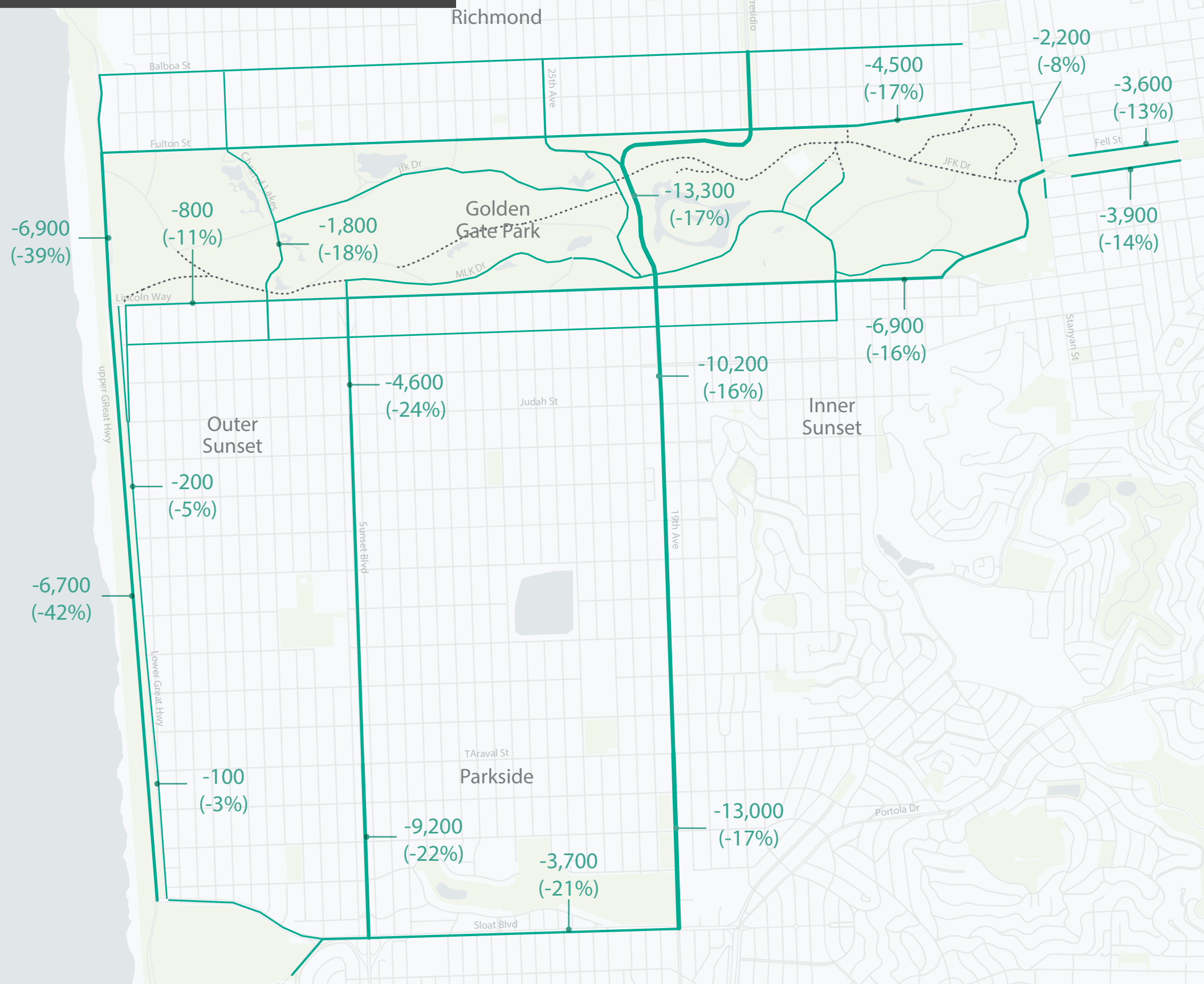

Appendix D: Transit Delay Analysis

Assignment of Pre-COVID Cross-Park Vehicle Trips to 8th Ave Route

AM Peak Hour

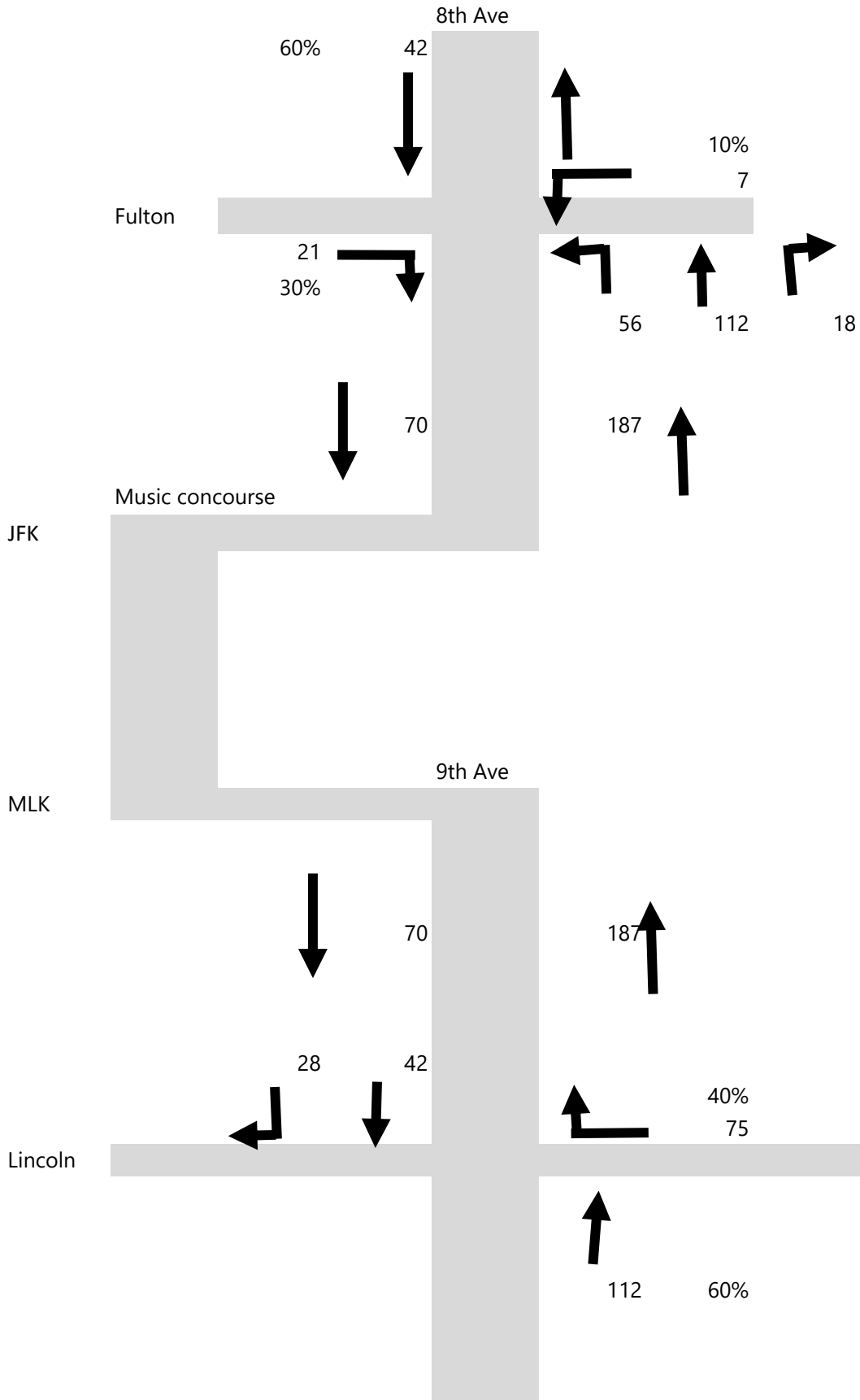

Assignment of Pre-COVID Cross-Park Vehicle Trips to 8th Ave Route

PM Peak Hour

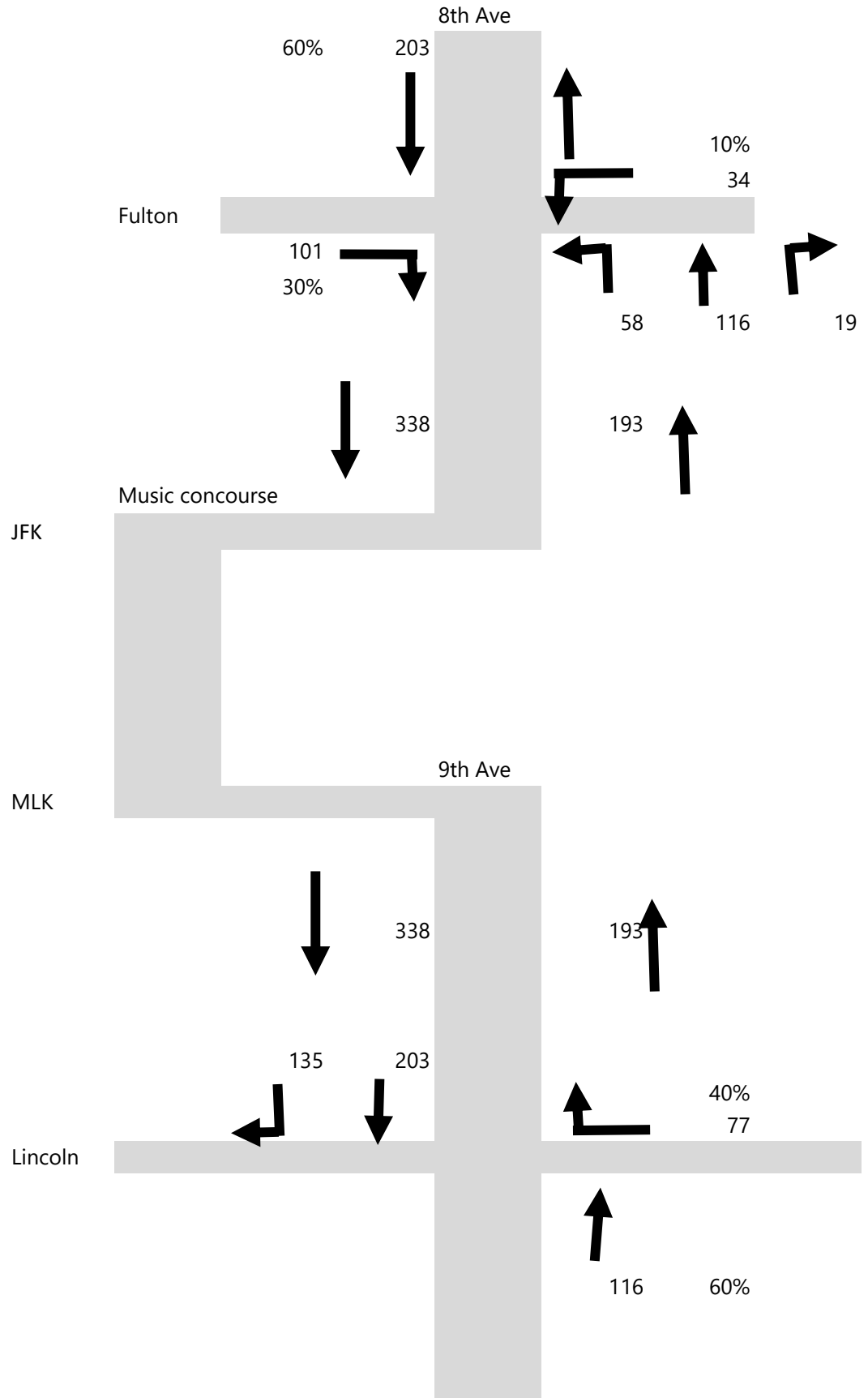

Existing Travel Times through Golden Gate Park

44 O'Shaughnessy	Time	October 2019*		October 2021*		Δ median (sec)
		Median (min)	Samples	Median (min)	Samples	
IB/NB Lincoln - Concourse	AM (6-9am)	2.7	172	2.9	71	7
	Midday (9am-2pm)	3.0	367	2.9	169	(5)
	PM (4-7pm)	2.87	177	3.10	79	14
	School (2-4pm)	2.93	114	2.95	73	2
IB/NB Concourse - Fulton	AM (6-9am)	1.63	171	1.67	72	2
	Midday (9am-2pm)	1.93	377	1.95	161	1
	PM (4-7pm)	1.92	186	1.82	83	(6)
	School (2-4pm)	1.91	116	1.78	68	(8)
OB/SB Fulton - Concourse	AM (6-9am)	2.30	162	2.40	55	6
	Midday (9am-2pm)	2.32	383	2.32	191	0
	PM (4-7pm)	2.58	223	2.32	127	(16)
	School (2-4pm)	2.37	161	2.33	81	(2)
OB/SB Concourse - Lincoln	AM (6-9am)	2.38	146	2.58	41	13
	Midday (9am-2pm)	2.77	370	2.58	202	(11)
	PM (4-7pm)	2.75	227	2.71	128	(3)
	School (2-4pm)	3.0	157	2.6	81	(20)

*Weekdays excluding holidays on 10/14/19, 10/11/21
 Travel time in minutes (door open to door open)
<https://stats.sfmta.com/#/views/TravelTime-StopToStop/CustomStopToStopTravelTime?iid=1>

Total Travel Times

IB/NB Lincoln - Concourse	AM (6-9am)	4.4		4.5		9
	Midday (9am-2pm)	4.9		4.8		(4)
	PM (4-7pm)	4.78		4.92		8
	School (2-4pm)	4.83		4.73		(6)
OB/SB Fulton - Concourse	AM (6-9am)	4.7		5.0		19
	Midday (9am-2pm)	5.1		4.9		(11)
	PM (4-7pm)	5.33		5.03		(19)
	School (2-4pm)	5.33		4.97		(22)

GGP Transit Delay Assessment for 44 O'Shaughnessy

Existing¹

Intersection	AM Peak Hour ²		PM Peak Hour ²	
	Southbound	Northbound	Southbound	Northbound
8th Street/Fulton Street	20	6	16	5
8th Ave/JFK/Music Concourse/Tea Garden ³	10	10	10	10
Martin Luther King Jr Drive/Nancy Pelosi Drive	6	14	8	10
9th Street/Lincoln Way	25	29	25	22
Total Vehicle Delay (seconds)	61	59	59	47

Existing with 8th Avenue Open

Intersection	AM Peak Hour		PM Peak Hour	
	Southbound	Northbound	Southbound	Northbound
8th Street/Fulton Street	20	19	24	19
8th Ave/JFK/Music Concourse/Tea Garden	17	18	41	23
Martin Luther King Jr Drive/Nancy Pelosi Drive	6	17	46	17
9th Street/Lincoln Way	27	32	90	26
Total Vehicle Delay (seconds)	70	86	201	85

Net Change

Intersection	AM Peak Hour		PM Peak Hour	
	Southbound	Northbound	Southbound	Northbound
8th Street/Fulton Street	0	13	8	14
8th Ave/JFK/Music Concourse/Tea Garden	7	8	31	13
Martin Luther King Jr Drive/Nancy Pelosi Drive	0	3	38	7
9th Street/Lincoln Way	2	3	65	4
Total Vehicle Delay (seconds)	9	27	142	38
Total Added Delay (MM:SS) ⁴	0:09	0:27	2:22	0:38

Notes:

1. This table presents the approach delay from the SimTraffic outputs in seconds.
2. AM and PM peak hours represents between 8-9 am and 5-6 pm, respectively.
3. Existing delay for buses estimated based on observations of occasional conflicts with peds or bikes that result in <10 seconds of delay crossing JFK.
4. Pre-pandemic travel times for 44 O'Shaughnessy from Lincoln Way to Fulton Avenue ranged from 4 to 5 minutes.

SimTraffic Post-Processor
Average Results from 10 Runs
Volume and Delay by Movement

SF GGP JFK
Existing
AM Peak Hour

Intersection 1 8th Avenue/Fulton Street Signal

Direction	Movement	Demand Volume (vph)	Served Volume (vph)		Total Delay (sec/veh)		LOS
			Average	Percent	Average	Std. Dev.	
NB	Left Turn						
	Through	4	3	82.5%	5.7	7.1	A
	Right Turn	2	3	125.0%	1.5	2.9	A
	Subtotal	6	6	96.7%	6.2	5.9	A
SB	Left Turn	55	52	94.7%	23.5	4.0	C
	Through	7	5	68.6%	2.6	7.2	A
	Right Turn	18	18	98.1%	9.6	6.3	A
	Subtotal	80	75	93.2%	20.3	4.6	C
EB	Left Turn	1	1	105.0%	4.7	14.9	A
	Through	1,272	1,277	100.4%	18.7	2.1	B
	Right Turn	1	2	160.0%	2.4	7.4	A
	Subtotal	1,274	1,279	100.4%	18.8	2.1	B
WB	Left Turn						
	Through	748	765	102.3%	14.7	2.0	B
	Right Turn	22	19	86.4%	9.1	4.8	A
	Subtotal	770	784	101.8%	14.6	2.0	B
Total		2,130	2,144	100.7%	17.3	1.5	B

Intersection 2 Music Concourse Drive/John F Kennedy Drive All-way Stop

Direction	Movement	Demand Volume (vph)	Served Volume (vph)		Total Delay (sec/veh)		LOS
			Average	Percent	Average	Std. Dev.	
NB	Left Turn						
	Through						
	Right Turn						
	Subtotal						
SB	Left Turn						
	Through						
	Right Turn						
	Subtotal						
EB	Left Turn						
	Through						
	Right Turn						
	Subtotal						
WB	Left Turn						
	Through						
	Right Turn						
	Subtotal						
Total							

SimTraffic Post-Processor
Average Results from 10 Runs
Volume and Delay by Movement

SF GGP JFK
Existing
AM Peak Hour

Intersection 3 8th Avenue/John F Kennedy Drive All-way Stop

Direction	Movement	Demand Volume (vph)	Served Volume (vph)		Total Delay (sec/veh)		
			Average	Percent	Average	Std. Dev.	LOS
NB	Left Turn						
	Through						
	Right Turn						
	Subtotal						
SB	Left Turn						
	Through						
	Right Turn						
	Subtotal						
EB	Left Turn						
	Through						
	Right Turn						
	Subtotal						
WB	Left Turn						
	Through						
	Right Turn						
	Subtotal						
Total							

Intersection 4 Martin Luther King Jr. Drive/Nancy Pelosi Drive All-way Stop

Direction	Movement	Demand Volume (vph)	Served Volume (vph)		Total Delay (sec/veh)		
			Average	Percent	Average	Std. Dev.	LOS
NB	Left Turn						
	Through	315	325	103.1%	13.7	3.7	B
	Right Turn	32	34	106.9%	12.3	4.8	B
	Subtotal	347	359	103.4%	13.6	3.6	B
SB	Left Turn	18	16	87.2%	4.0	2.4	A
	Through	142	146	102.7%	5.7	0.7	A
	Right Turn						
	Subtotal	160	162	101.0%	5.6	0.7	A
EB	Left Turn						
	Through						
	Right Turn						
	Subtotal						
WB	Left Turn	16	17	107.2%	4.3	2.1	A
	Through						
	Right Turn	18	20	112.2%	4.5	2.0	A
	Subtotal	34	37	109.9%	4.4	1.9	A
Total		541	558	103.1%	10.8	2.6	B

SimTraffic Post-Processor
Average Results from 10 Runs
Volume and Delay by Movement

SF GGP JFK
Existing
AM Peak Hour

Intersection 5

9th Avenue/Lincoln Way

Signal

Direction	Movement	Demand Volume (vph)	Served Volume (vph)		Total Delay (sec/veh)		LOS
			Average	Percent	Average	Std. Dev.	
NB	Left Turn	2	1	72.5%	12.7	22.6	B
	Through	265	276	104.1%	30.1	2.8	C
	Right Turn	64	70	110.0%	20.3	6.8	C
	Subtotal	331	348	105.0%	28.5	2.4	C
SB	Left Turn						
	Through	138	141	102.2%	26.6	4.5	C
	Right Turn	20	20	102.0%	9.7	4.4	A
	Subtotal	158	161	102.2%	24.5	4.4	C
EB	Left Turn	2	2	75.0%	9.2	17.6	A
	Through	1,464	1,484	101.3%	19.4	2.3	B
	Right Turn	19	18	93.9%	13.2	4.8	B
	Subtotal	1,485	1,503	101.2%	19.3	2.3	B
WB	Left Turn						
	Through	1,002	1,002	100.0%	13.6	1.5	B
	Right Turn	80	74	92.5%	11.8	4.3	B
	Subtotal	1,082	1,076	99.4%	13.5	1.6	B
Total		3,056	3,088	101.0%	18.6	1.2	B

**SimTraffic Post-Processor
Average Results from 10 Runs
Volume and Delay by Movement**

**SF GGP JFK
Existing
PM Peak Hour**

Intersection 1

8th Avenue/Fulton Street

Signal

Direction	Movement	Demand Volume (vph)	Served Volume (vph)		Total Delay (sec/veh)		
			Average	Percent	Average	Std. Dev.	LOS
NB	Left Turn						
	Through	6	6	95.8%	5.3	6.6	A
	Right Turn	1	2	185.0%	0.8	1.7	A
	Subtotal	7	8	108.6%	5.2	6.2	A
SB	Left Turn	55	55	99.2%	16.4	6.2	B
	Through	5	6	116.0%	20.6	17.9	C
	Right Turn	25	26	102.8%	12.6	9.7	B
	Subtotal	85	86	101.2%	15.5	5.0	B
EB	Left Turn	2	2	90.0%	6.9	19.4	A
	Through	1,004	997	99.3%	16.6	3.0	B
	Right Turn	2	3	145.0%	5.2	8.0	A
	Subtotal	1,008	1,002	99.4%	16.6	3.0	B
WB	Left Turn						
	Through	1,068	1,043	97.6%	16.5	1.7	B
	Right Turn	31	34	109.2%	10.2	4.8	B
	Subtotal	1,099	1,077	98.0%	16.3	1.7	B
Total		2,199	2,172	98.8%	16.4	1.3	B

Intersection 2

Music Concourse Drive/John F Kennedy Drive

All-way Stop

Direction	Movement	Demand Volume (vph)	Served Volume (vph)		Total Delay (sec/veh)		
			Average	Percent	Average	Std. Dev.	LOS
NB	Left Turn						
	Through						
	Right Turn						
	Subtotal						
SB	Left Turn						
	Through						
	Right Turn						
	Subtotal						
EB	Left Turn						
	Through						
	Right Turn						
	Subtotal						
WB	Left Turn						
	Through						
	Right Turn						
	Subtotal						
Total							

SimTraffic Post-Processor
Average Results from 10 Runs
Volume and Delay by Movement

SF GGP JFK
Existing
PM Peak Hour

Intersection 4

Martin Luther King Jr. Drive/Nancy Pelosi Drive

All-way Stop

Direction	Movement	Demand Volume (vph)	Served Volume (vph)		Total Delay (sec/veh)		
			Average	Percent	Average	Std. Dev.	LOS
NB	Left Turn						
	Through	192	208	108.3%	9.9	1.9	A
	Right Turn	57	55	96.9%	9.8	2.7	A
	Subtotal	249	263	105.7%	9.9	2.0	A
SB	Left Turn	42	41	97.3%	7.3	1.2	A
	Through	201	203	100.8%	7.1	0.5	A
	Right Turn						
	Subtotal	243	243	100.2%	7.1	0.4	A
EB	Left Turn						
	Through						
	Right Turn						
	Subtotal						
WB	Left Turn	35	33	95.6%	7.0	1.7	A
	Through						
	Right Turn	30	31	102.5%	5.7	1.3	A
	Subtotal	65	64	98.8%	6.6	1.0	A
Total		557	571	102.5%	8.3	1.0	A

Intersection 5

9th Avenue/Lincoln Way

Signal

Direction	Movement	Demand Volume (vph)	Served Volume (vph)		Total Delay (sec/veh)		
			Average	Percent	Average	Std. Dev.	LOS
NB	Left Turn	2	2	90.0%	27.5	31.3	C
	Through	169	174	103.2%	24.4	6.6	C
	Right Turn	77	80	104.4%	14.9	3.9	B
	Subtotal	248	257	103.4%	22.0	4.9	C
SB	Left Turn	3	3	85.0%	10.6	20.0	B
	Through	190	194	102.2%	25.3	4.0	C
	Right Turn	43	42	98.0%	24.4	8.0	C
	Subtotal	236	239	101.2%	25.3	4.4	C
EB	Left Turn						
	Through	1,133	1,133	100.0%	18.2	1.4	B
	Right Turn	54	61	112.4%	14.4	4.1	B
	Subtotal	1,187	1,194	100.6%	18.0	1.4	B
WB	Left Turn	3	3	96.7%	17.8	27.9	B
	Through	1,462	1,473	100.8%	24.4	3.9	C
	Right Turn	80	83	103.8%	20.7	5.7	C
	Subtotal	1,545	1,559	100.9%	24.2	3.9	C
Total		3,216	3,248	101.0%	21.9	2.2	C

SimTraffic Post-Processor
Average Results from 10 Runs
Volume and Delay by Movement

SF JFK GGP
Existing Plus Project
AM Peak Hour

Intersection 1 **8th Avenue/Fulton Street** **Signal**

Direction	Movement	Demand Volume (vph)	Served Volume (vph)		Total Delay (sec/veh)		
			Average	Percent	Average	Std. Dev.	LOS
NB	Left Turn	56	54	96.7%	22.9	1.9	C
	Through	116	121	104.5%	17.8	3.2	B
	Right Turn	20	20	98.0%	15.3	11.7	B
	Subtotal	192	195	101.5%	18.8	2.2	B
SB	Left Turn	55	57	103.5%	23.6	6.0	C
	Through	49	50	103.0%	19.4	4.8	B
	Right Turn	18	20	111.4%	13.2	6.3	B
	Subtotal	122	127	104.4%	19.8	4.4	B
EB	Left Turn	1	1	135.0%	1.8	3.9	A
	Through	1,272	1,262	99.2%	20.6	2.3	C
	Right Turn	22	21	97.5%	14.8	6.8	B
	Subtotal	1,295	1,284	99.2%	20.5	2.3	C
WB	Left Turn	7	8	117.1%	37.8	21.1	D
	Through	748	735	98.3%	19.2	4.6	B
	Right Turn	22	22	101.4%	9.7	6.6	A
	Subtotal	777	766	98.6%	19.2	4.8	B
Total		2,386	2,373	99.4%	19.9	2.4	B

Intersection 2 **Music Concourse Drive/John F Kennedy Drive** **All-way Stop**

Direction	Movement	Demand Volume (vph)	Served Volume (vph)		Total Delay (sec/veh)		
			Average	Percent	Average	Std. Dev.	LOS
NB	Left Turn						
	Through						
	Right Turn	192	190	98.9%	9.9	4.3	A
	Subtotal	192	190	98.9%	9.9	4.3	A
SB	Left Turn						
	Through						
	Right Turn						
	Subtotal						
EB	Left Turn						
	Through						
	Right Turn						
	Subtotal						
WB	Left Turn	78	79	101.1%	8.0	2.0	A
	Through						
	Right Turn						
	Subtotal	78	79	101.1%	8.0	2.0	A
Total		270	269	99.5%	9.4	3.5	A

SimTraffic Post-Processor
Average Results from 10 Runs
Volume and Delay by Movement

SF JFK GGP
Existing Plus Project
AM Peak Hour

Intersection 3 8th Avenue/John F. Kennedy Drive All-way Stop

Direction	Movement	Demand Volume (vph)	Served Volume (vph)		Total Delay (sec/veh)		
			Average	Percent	Average	Std. Dev.	LOS
NB	Left Turn						
	Through						
	Right Turn						
	Subtotal						
SB	Left Turn						
	Through						
	Right Turn	78	79	100.8%	9.4	2.3	A
	Subtotal	78	79	100.8%	9.4	2.3	A
EB	Left Turn	192	190	98.8%	7.6	1.3	A
	Through						
	Right Turn						
	Subtotal	192	190	98.8%	7.6	1.3	A
WB	Left Turn						
	Through						
	Right Turn						
	Subtotal						
Total		270	268	99.4%	8.1	1.3	A

Intersection 4 Martin Luther King Jr. Drive/Nancy Pelosi Drive All-way Stop

Direction	Movement	Demand Volume (vph)	Served Volume (vph)		Total Delay (sec/veh)		
			Average	Percent	Average	Std. Dev.	LOS
NB	Left Turn						
	Through	502	507	101.1%	16.7	1.6	C
	Right Turn	32	32	101.3%	15.5	3.9	C
	Subtotal	534	540	101.1%	16.6	1.7	C
SB	Left Turn	18	16	88.9%	5.4	1.1	A
	Through	212	212	99.9%	6.5	0.5	A
	Right Turn						
	Subtotal	230	228	99.1%	6.4	0.4	A
EB	Left Turn						
	Through						
	Right Turn						
	Subtotal						
WB	Left Turn	16	16	98.4%	5.7	1.2	A
	Through						
	Right Turn	18	19	104.7%	5.2	1.7	A
	Subtotal	34	35	101.8%	5.3	1.2	A
Total		798	802	100.5%	13.4	1.3	B

SimTraffic Post-Processor
Average Results from 10 Runs
Volume and Delay by Movement

SF JFK GGP
Existing Plus Project
AM Peak Hour

Intersection 5

9th Avenue/Lincoln Way/Lincoln Way

Signal

Direction	Movement	Demand Volume (vph)	Served Volume (vph)		Total Delay (sec/veh)		LOS
			Average	Percent	Average	Std. Dev.	
NB	Left Turn	2	2	90.0%	14.3	30.2	B
	Through	377	375	99.5%	34.4	5.6	C
	Right Turn	64	63	98.7%	16.3	6.8	B
	Subtotal	443	440	99.3%	31.8	4.9	C
SB	Left Turn						
	Through	180	188	104.6%	29.3	2.5	C
	Right Turn	48	46	96.7%	17.1	6.3	B
	Subtotal	228	235	102.9%	26.9	2.6	C
EB	Left Turn	2	2	82.5%	4.6	14.5	A
	Through	1,464	1,465	100.1%	17.8	1.5	B
	Right Turn	19	20	106.3%	17.2	9.0	B
	Subtotal	1,485	1,487	100.1%	17.8	1.5	B
WB	Left Turn						
	Through	1,002	989	98.7%	14.9	1.4	B
	Right Turn	155	158	101.6%	14.0	2.5	B
	Subtotal	1,157	1,146	99.1%	14.7	1.2	B
Total		3,313	3,308	99.8%	19.2	1.0	B

SimTraffic Post-Processor
 Average Results from 10 Runs
 Volume and Delay by Movement

SF JFK GPP
 Existing Plus Project
 PM Peak Hour

Intersection 1

8th Avenue/Fulton Street

Signal

Direction	Movement	Demand Volume (vph)	Served Volume (vph)		Total Delay (sec/veh)		LOS
			Average	Percent	Average	Std. Dev.	
NB	Left Turn	58	55	94.7%	25.9	4.6	C
	Through	122	124	101.8%	16.5	2.7	B
	Right Turn	20	22	108.5%	14.8	12.7	B
	Subtotal	200	201	100.4%	18.9	2.4	B
SB	Left Turn	55	55	100.4%	22.2	8.1	C
	Through	208	210	101.1%	25.1	4.8	C
	Right Turn	25	26	102.0%	21.8	10.3	C
	Subtotal	288	291	101.0%	24.3	5.5	C
EB	Left Turn	2	2	85.0%	11.2	24.6	B
	Through	1,004	986	98.2%	18.4	2.7	B
	Right Turn	103	104	100.6%	13.2	3.7	B
	Subtotal	1,109	1,091	98.4%	17.9	2.6	B
WB	Left Turn	34	33	97.9%	62.5	25.1	E
	Through	1,068	1,065	99.7%	37.6	13.2	D
	Right Turn	31	31	101.3%	17.2	6.7	B
	Subtotal	1,133	1,130	99.7%	37.8	13.4	D
Total		2,730	2,713	99.4%	27.0	5.7	C

Intersection 2

Musical Concourse Drive/John F Kennedy Drive

All-way Stop

Direction	Movement	Demand Volume (vph)	Served Volume (vph)		Total Delay (sec/veh)		LOS
			Average	Percent	Average	Std. Dev.	
NB	Left Turn						
	Through						
	Right Turn	200	196	98.1%	11.8	3.5	B
	Subtotal	200	196	98.1%	11.8	3.5	B
SB	Left Turn						
	Through						
	Right Turn						
	Subtotal						
EB	Left Turn						
	Through						
	Right Turn						
	Subtotal						
WB	Left Turn	345	344	99.6%	14.4	3.3	B
	Through						
	Right Turn						
	Subtotal	345	344	99.6%	14.4	3.3	B
Total		545	540	99.1%	13.6	2.7	B

SimTraffic Post-Processor
Average Results from 10 Runs
Volume and Delay by Movement

SF JFK GPP
Existing Plus Project
PM Peak Hour

Intersection 3 8th Avenue/John F. Kennedy Drive All-way Stop

Direction	Movement	Demand Volume (vph)	Served Volume (vph)		Total Delay (sec/veh)		
			Average	Percent	Average	Std. Dev.	LOS
NB	Left Turn						
	Through						
	Right Turn						
	Subtotal						
SB	Left Turn						
	Through						
	Right Turn	345	344	99.7%	26.7	5.9	C
	Subtotal	345	344	99.7%	26.7	5.9	C
EB	Left Turn	200	196	98.2%	10.5	2.0	B
	Through						
	Right Turn						
	Subtotal	200	196	98.2%	10.5	2.0	B
WB	Left Turn						
	Through						
	Right Turn						
	Subtotal						
Total		545	540	99.2%	20.9	4.0	C

Intersection 4 Martin Luther King Jr. Drive/Nancy Pelosi Drive All-way Stop

Direction	Movement	Demand Volume (vph)	Served Volume (vph)		Total Delay (sec/veh)		
			Average	Percent	Average	Std. Dev.	LOS
NB	Left Turn						
	Through	385	394	102.2%	16.7	6.6	C
	Right Turn	57	59	103.9%	15.4	8.7	C
	Subtotal	442	453	102.4%	16.6	6.8	C
SB	Left Turn	42	44	105.0%	46.2	31.2	E
	Through	539	540	100.2%	46.3	34.5	E
	Right Turn						
	Subtotal	581	584	100.5%	46.4	34.2	E
EB	Left Turn						
	Through						
	Right Turn						
	Subtotal						
WB	Left Turn	35	33	94.9%	11.4	4.4	B
	Through						
	Right Turn	30	29	96.3%	7.1	3.6	A
	Subtotal	65	62	95.5%	9.6	3.6	A
Total		1,088	1,099	101.0%	32.3	18.7	D

SimTraffic Post-Processor
Average Results from 10 Runs
Volume and Delay by Movement

SF JFK GPP
Existing Plus Project
PM Peak Hour

Intersection 5

9th Avenue/Lincoln Way

Signal

Direction	Movement	Demand Volume (vph)	Served Volume (vph)		Total Delay (sec/veh)		LOS
			Average	Percent	Average	Std. Dev.	
NB	Left Turn	2	1	70.0%	9.2	20.7	A
	Through	285	283	99.1%	29.6	3.6	C
	Right Turn	77	78	101.7%	12.1	2.5	B
	Subtotal	364	362	99.5%	25.9	3.6	C
SB	Left Turn	3	3	83.3%	47.6	62.5	D
	Through	393	392	99.8%	90.9	31.8	F
	Right Turn	178	178	99.9%	87.4	30.5	F
	Subtotal	574	573	99.8%	90.0	31.3	F
EB	Left Turn						
	Through	1,133	1,156	102.0%	17.0	1.8	B
	Right Turn	54	55	101.5%	15.0	6.0	B
	Subtotal	1,187	1,211	102.0%	16.9	1.9	B
WB	Left Turn	3	3	86.7%	14.0	22.0	B
	Through	1,462	1,462	100.0%	29.1	10.1	C
	Right Turn	157	157	99.7%	27.3	11.1	C
	Subtotal	1,622	1,621	99.9%	29.0	10.2	C
Total		3,747	3,767	100.5%	34.1	5.8	C

Roadway Arterial Capacity Sensitivity Test Results

Eastbound and westbound through movements were increased by 40 percent in the AM and 20 percent in the PM peak hour to conduct a sensitivity test on the capacity of Fulton Street and Lincoln Way. This sensitivity test was conducted in Synchro as the operations on Fulton Street and Lincoln Way are currently unaffected by downstream congestion during the typical AM and PM peak hour.

HCM 6th Signalized Intersection Summary
1: 8th Street & Fulton Street

JFK Analysis
AM Existing Plus Project



Movement	EBL	EBT	EBR	WBL	WBT	WBR	NBL	NBT	NBR	SBL	SBT	SBR
Lane Configurations		↔			↔		↔	↔			↔	
Traffic Volume (veh/h)	1	1654	22	7	972	22	56	116	20	55	49	18
Future Volume (veh/h)	1	1654	22	7	972	22	56	116	20	55	49	18
Initial Q (Qb), veh	0	0	0	0	0	0	0	0	0	0	0	0
Ped-Bike Adj(A_pbT)	1.00		0.92	1.00		0.90	0.98		0.95	0.98		0.95
Parking Bus, Adj	1.00	1.00	1.00	1.00	1.00	1.00	1.00	1.00	1.00	1.00	1.00	1.00
Work Zone On Approach		No			No			No			No	
Adj Sat Flow, veh/h/ln	1870	1870	1870	1870	1870	1870	1870	1870	1870	1870	1870	1870
Adj Flow Rate, veh/h	1	1705	23	7	1002	20	58	120	20	57	51	7
Peak Hour Factor	0.97	0.97	0.97	0.97	0.97	0.97	0.97	0.97	0.97	0.97	0.97	0.97
Percent Heavy Veh, %	2	2	2	2	2	2	2	2	2	2	2	2
Cap, veh/h	40	1736	23	41	1499	34	579	595	99	301	255	32
Arrive On Green	0.49	0.49	0.49	0.49	0.49	0.49	0.38	0.38	0.38	0.38	0.38	0.38
Sat Flow, veh/h	0	3511	47	1	3031	68	1318	1551	258	628	664	84
Grp Volume(v), veh/h	907	0	822	537	0	492	58	0	140	115	0	0
Grp Sat Flow(s),veh/h/ln	1870	0	1688	1419	0	1681	1318	0	1809	1376	0	0
Q Serve(g_s), s	3.0	0.0	43.2	1.3	0.0	18.8	0.0	0.0	4.7	2.3	0.0	0.0
Cycle Q Clear(g_c), s	42.8	0.0	43.2	44.5	0.0	18.8	2.7	0.0	4.7	7.0	0.0	0.0
Prop In Lane	0.00		0.03	0.01		0.04	1.00		0.14	0.50		0.06
Lane Grp Cap(c), veh/h	965	0	835	742	0	831	579	0	694	587	0	0
V/C Ratio(X)	0.94	0.00	0.99	0.72	0.00	0.59	0.10	0.00	0.20	0.20	0.00	0.00
Avail Cap(c_a), veh/h	965	0	835	742	0	831	579	0	694	587	0	0
HCM Platoon Ratio	1.00	1.00	1.00	1.00	1.00	1.00	1.00	1.00	1.00	1.00	1.00	1.00
Upstream Filter(I)	1.00	0.00	1.00	1.00	0.00	1.00	1.00	0.00	1.00	1.00	0.00	0.00
Uniform Delay (d), s/veh	22.3	0.0	22.4	17.6	0.0	16.3	18.0	0.0	18.5	19.1	0.0	0.0
Incr Delay (d2), s/veh	17.7	0.0	27.7	6.1	0.0	3.1	0.3	0.0	0.7	0.7	0.0	0.0
Initial Q Delay(d3),s/veh	0.0	0.0	0.0	0.0	0.0	0.0	0.0	0.0	0.0	0.0	0.0	0.0
%ile BackOfQ(50%),veh/ln	21.9	0.0	22.1	8.8	0.0	7.5	0.8	0.0	2.1	1.8	0.0	0.0
Unsig. Movement Delay, s/veh												
LnGrp Delay(d),s/veh	40.0	0.0	50.2	23.6	0.0	19.3	18.3	0.0	19.2	19.9	0.0	0.0
LnGrp LOS	D	A	D	C	A	B	B	A	B	B	A	A
Approach Vol, veh/h		1729			1029			198				115
Approach Delay, s/veh		44.8			21.6			18.9				19.9
Approach LOS		D			C			B				B
Timer - Assigned Phs		2		4		6		8				
Phs Duration (G+Y+Rc), s		50.0		40.0		50.0		40.0				
Change Period (Y+Rc), s		5.5		5.5		5.5		5.5				
Max Green Setting (Gmax), s		44.5		34.5		44.5		34.5				
Max Q Clear Time (g_c+I1), s		45.2		9.0		46.5		6.7				
Green Ext Time (p_c), s		0.0		0.1		0.0		0.1				
Intersection Summary												
HCM 6th Ctrl Delay				34.4								
HCM 6th LOS				C								

HCM 6th Signalized Intersection Summary
 5: 9th Street/Martin Luther King Jr Drive & Lincoln Way

















JFK Analysis
 AM Existing Plus Project



Movement	EBL	EBT	EBR	WBL	WBT	WBR	NBL	NBT	NBR	SBL	SBT	SBR
Lane Configurations		↕↕			↕↕			↑	↗		↑	↗
Traffic Volume (veh/h)	2	1903	19	0	1303	155	2	377	64	0	180	48
Future Volume (veh/h)	2	1903	19	0	1303	155	2	377	64	0	180	48
Initial Q (Qb), veh	0	0	0	0	0	0	0	0	0	0	0	0
Ped-Bike Adj(A_pbT)	1.00		0.90	1.00		0.92	0.95		0.88	1.00		0.91
Parking Bus, Adj	1.00	1.00	1.00	1.00	1.00	1.00	1.00	1.00	1.00	1.00	1.00	1.00
Work Zone On Approach		No			No			No			No	
Adj Sat Flow, veh/h/ln	1870	1870	1870	1870	1870	1870	1870	1870	1870	0	1870	1870
Adj Flow Rate, veh/h	2	2024	19	0	1386	160	2	401	50	0	191	35
Peak Hour Factor	0.94	0.94	0.94	0.94	0.94	0.94	0.94	0.94	0.94	0.94	0.94	0.94
Percent Heavy Veh, %	2	2	2	2	2	2	2	2	2	0	2	2
Cap, veh/h	33	2068	19	0	1864	213	33	577	430	0	578	445
Arrive On Green	0.59	0.59	0.59	0.00	0.59	0.59	0.31	0.31	0.31	0.00	0.31	0.31
Sat Flow, veh/h	0	3526	33	0	3273	363	2	1868	1392	0	1870	1439
Grp Volume(v), veh/h	1071	0	974	0	768	778	403	0	50	0	191	35
Grp Sat Flow(s),veh/h/ln	1868	0	1692	0	1777	1766	1869	0	1392	0	1870	1439
Q Serve(g_s), s	5.8	0.0	61.8	0.0	34.6	35.8	0.0	0.0	2.8	0.0	8.6	1.9
Cycle Q Clear(g_c), s	61.0	0.0	61.8	0.0	34.6	35.8	20.9	0.0	2.8	0.0	8.6	1.9
Prop In Lane	0.00		0.02	0.00		0.21	0.00		1.00	0.00		1.00
Lane Grp Cap(c), veh/h	1128	0	992	0	1042	1035	611	0	430	0	578	445
V/C Ratio(X)	0.95	0.00	0.98	0.00	0.74	0.75	0.66	0.00	0.12	0.00	0.33	0.08
Avail Cap(c_a), veh/h	1128	0	992	0	1042	1035	611	0	430	0	578	445
HCM Platoon Ratio	1.00	1.00	1.00	1.00	1.00	1.00	1.00	1.00	1.00	1.00	1.00	1.00
Upstream Filter(I)	1.00	0.00	1.00	0.00	1.00	1.00	1.00	0.00	1.00	0.00	1.00	1.00
Uniform Delay (d), s/veh	22.0	0.0	22.2	0.0	16.6	16.8	33.5	0.0	27.2	0.0	29.2	26.9
Incr Delay (d2), s/veh	17.0	0.0	24.6	0.0	4.7	5.0	5.5	0.0	0.5	0.0	1.5	0.3
Initial Q Delay(d3),s/veh	0.0	0.0	0.0	0.0	0.0	0.0	0.0	0.0	0.0	0.0	0.0	0.0
%ile BackOfQ(50%),veh/ln	29.7	0.0	29.2	0.0	14.5	15.0	10.4	0.0	1.0	0.0	4.1	0.7
Unsig. Movement Delay, s/veh												
LnGrp Delay(d),s/veh	39.1	0.0	46.8	0.0	21.2	21.9	39.0	0.0	27.8	0.0	30.8	27.3
LnGrp LOS	D	A	D	A	C	C	D	A	C	A	C	C
Approach Vol, veh/h		2045			1546			453			226	
Approach Delay, s/veh		42.7			21.5			37.7			30.2	
Approach LOS		D			C			D			C	
Timer - Assigned Phs		2		4		6		8				
Phs Duration (G+Y+Rc), s		70.0		40.0		70.0		40.0				
Change Period (Y+Rc), s		5.5		6.0		5.5		6.0				
Max Green Setting (Gmax), s		64.5		34.0		64.5		34.0				
Max Q Clear Time (g_c+I1), s		63.8		10.6		37.8		22.9				
Green Ext Time (p_c), s		0.7		1.2		13.8		2.1				
Intersection Summary												
HCM 6th Ctrl Delay				33.9								
HCM 6th LOS				C								

HCM 6th Signalized Intersection Summary
1: 8th Street & Fulton Street

JFK Analysis
PM Existing Plus Project

												
Movement	EBL	EBT	EBR	WBL	WBT	WBR	NBL	NBT	NBR	SBL	SBT	SBR
Lane Configurations												
Traffic Volume (veh/h)	2	1205	103	34	1282	31	58	122	20	55	208	25
Future Volume (veh/h)	2	1205	103	34	1282	31	58	122	20	55	208	25
Initial Q (Qb), veh	0	0	0	0	0	0	0	0	0	0	0	0
Ped-Bike Adj(A_pbT)	1.00		0.91	1.00		0.91	0.98		0.94	0.97		0.96
Parking Bus, Adj	1.00	1.00	1.00	1.00	1.00	1.00	1.00	1.00	1.00	1.00	1.00	1.00
Work Zone On Approach		No			No			No			No	
Adj Sat Flow, veh/h/ln	1870	1870	1870	1870	1870	1870	1870	1870	1870	1870	1870	1870
Adj Flow Rate, veh/h	2	1242	106	35	1322	30	60	126	20	57	214	10
Peak Hour Factor	0.97	0.97	0.97	0.97	0.97	0.97	0.97	0.97	0.97	0.97	0.97	0.97
Percent Heavy Veh, %	2	2	2	2	2	2	2	2	2	2	2	2
Cap, veh/h	40	1590	135	56	1429	36	477	598	95	149	532	23
Arrive On Green	0.49	0.49	0.49	0.49	0.49	0.49	0.38	0.38	0.38	0.38	0.38	0.38
Sat Flow, veh/h	1	3216	273	28	2890	72	1138	1561	248	263	1388	61
Grp Volume(v), veh/h	720	0	630	688	0	699	60	0	146	281	0	0
Grp Sat Flow(s),veh/h/ln	1868	0	1622	1310	0	1681	1138	0	1809	1712	0	0
Q Serve(g_s), s	0.0	0.0	28.9	15.6	0.0	32.4	0.0	0.0	4.9	2.5	0.0	0.0
Cycle Q Clear(g_c), s	28.5	0.0	28.9	44.5	0.0	32.4	4.6	0.0	4.9	10.2	0.0	0.0
Prop In Lane	0.00		0.17	0.05		0.04	1.00		0.14	0.20		0.04
Lane Grp Cap(c), veh/h	964	0	802	690	0	831	477	0	693	704	0	0
V/C Ratio(X)	0.75	0.00	0.79	1.00	0.00	0.84	0.13	0.00	0.21	0.40	0.00	0.00
Avail Cap(c_a), veh/h	964	0	802	690	0	831	477	0	693	704	0	0
HCM Platoon Ratio	1.00	1.00	1.00	1.00	1.00	1.00	1.00	1.00	1.00	1.00	1.00	1.00
Upstream Filter(I)	1.00	0.00	1.00	1.00	0.00	1.00	1.00	0.00	1.00	1.00	0.00	0.00
Uniform Delay (d), s/veh	18.7	0.0	18.8	22.6	0.0	19.7	18.5	0.0	18.6	20.2	0.0	0.0
Incr Delay (d2), s/veh	5.3	0.0	7.6	33.6	0.0	10.1	0.5	0.0	0.7	1.7	0.0	0.0
Initial Q Delay(d3),s/veh	0.0	0.0	0.0	0.0	0.0	0.0	0.0	0.0	0.0	0.0	0.0	0.0
%ile BackOfQ(50%),veh/ln	12.8	0.0	11.7	20.9	0.0	14.0	0.9	0.0	2.2	4.6	0.0	0.0
Unsig. Movement Delay, s/veh												
LnGrp Delay(d),s/veh	24.0	0.0	26.4	56.2	0.0	29.8	19.1	0.0	19.3	21.9	0.0	0.0
LnGrp LOS	C	A	C	E	A	C	B	A	B	C	A	A
Approach Vol, veh/h		1350			1387			206			281	
Approach Delay, s/veh		25.1			42.9			19.2			21.9	
Approach LOS		C			D			B			C	
Timer - Assigned Phs		2		4		6		8				
Phs Duration (G+Y+Rc), s		50.0		40.0		50.0		40.0				
Change Period (Y+Rc), s		5.5		5.5		5.5		5.5				
Max Green Setting (Gmax), s		44.5		34.5		44.5		34.5				
Max Q Clear Time (g_c+I1), s		30.9		12.2		46.5		6.9				
Green Ext Time (p_c), s		1.6		0.3		0.0		0.2				
Intersection Summary												
HCM 6th Ctrl Delay				32.1								
HCM 6th LOS				C								

HCM 6th Signalized Intersection Summary
 5: 9th Street/Martin Luther King Jr Drive & Lincoln Way

JFK Analysis
 PM Existing Plus Project



Movement	EBL	EBT	EBR	WBL	WBT	WBR	NBL	NBT	NBR	SBL	SBT	SBR
Lane Configurations		↕↕			↕↕			↑	↗		↑	↗
Traffic Volume (veh/h)	0	1360	54	3	1754	157	2	285	77	3	393	178
Future Volume (veh/h)	0	1360	54	3	1754	157	2	285	77	3	393	178
Initial Q (Qb), veh	0	0	0	0	0	0	0	0	0	0	0	0
Ped-Bike Adj(A_pbT)	1.00		0.85	1.00		0.85	0.98		0.78	0.93		0.78
Parking Bus, Adj	1.00	1.00	1.00	1.00	1.00	1.00	1.00	1.00	1.00	1.00	1.00	1.00
Work Zone On Approach		No			No			No			No	
Adj Sat Flow, veh/h/ln	1870	1870	1870	1870	1870	1870	1870	1870	1870	1870	1870	1870
Adj Flow Rate, veh/h	0	1447	54	3	1866	163	2	303	60	3	418	171
Peak Hour Factor	0.94	0.94	0.94	0.94	0.94	0.94	0.94	0.94	0.94	0.94	0.94	0.94
Percent Heavy Veh, %	2	2	2	2	2	2	2	2	2	2	2	2
Cap, veh/h	0	1939	72	33	1785	150	34	628	418	34	627	413
Arrive On Green	0.00	0.56	0.56	0.56	0.56	0.56	0.34	0.34	0.34	0.34	0.34	0.34
Sat Flow, veh/h	0	3562	129	1	3193	269	2	1866	1242	3	1865	1229
Grp Volume(v), veh/h	0	738	763	1064	0	968	305	0	60	421	0	171
Grp Sat Flow(s),veh/h/ln	0	1777	1820	1866	0	1596	1868	0	1242	1868	0	1229
Q Serve(g_s), s	0.0	34.5	35.0	11.0	0.0	61.5	0.0	0.0	3.7	0.0	0.0	11.8
Cycle Q Clear(g_c), s	0.0	34.5	35.0	61.5	0.0	61.5	14.2	0.0	3.7	21.2	0.0	11.8
Prop In Lane	0.00		0.07	0.00		0.17	0.01		1.00	0.01		1.00
Lane Grp Cap(c), veh/h	0	993	1018	1076	0	893	661	0	418	661	0	413
V/C Ratio(X)	0.00	0.74	0.75	0.99	0.00	1.08	0.46	0.00	0.14	0.64	0.00	0.41
Avail Cap(c_a), veh/h	0	993	1018	1076	0	893	661	0	418	661	0	413
HCM Platoon Ratio	1.00	1.00	1.00	1.00	1.00	1.00	1.00	1.00	1.00	1.00	1.00	1.00
Upstream Filter(I)	0.00	1.00	1.00	1.00	0.00	1.00	1.00	0.00	1.00	1.00	0.00	1.00
Uniform Delay (d), s/veh	0.0	18.3	18.4	24.8	0.0	24.3	28.9	0.0	25.5	31.3	0.0	28.1
Incr Delay (d2), s/veh	0.0	5.0	5.1	24.8	0.0	55.7	2.3	0.0	0.7	4.6	0.0	3.0
Initial Q Delay(d3),s/veh	0.0	0.0	0.0	0.0	0.0	0.0	0.0	0.0	0.0	0.0	0.0	0.0
%ile BackOfQ(50%),veh/ln	0.0	14.7	15.3	33.5	0.0	35.2	6.8	0.0	1.2	10.3	0.0	3.8
Unsig. Movement Delay, s/veh												
LnGrp Delay(d),s/veh	0.0	23.3	23.5	49.6	0.0	80.0	31.3	0.0	26.2	35.9	0.0	31.2
LnGrp LOS	A	C	C	D	A	F	C	A	C	D	A	C
Approach Vol, veh/h		1501			2032			365				592
Approach Delay, s/veh		23.4			64.1			30.4				34.5
Approach LOS		C			E			C				C
Timer - Assigned Phs		2		4		6		8				
Phs Duration (G+Y+Rc), s		67.0		43.0		67.0		43.0				
Change Period (Y+Rc), s		5.5		6.0		5.5		6.0				
Max Green Setting (Gmax), s		61.5		37.0		61.5		37.0				
Max Q Clear Time (g_c+I1), s		37.0		23.2		63.5		16.2				
Green Ext Time (p_c), s		12.5		2.9		0.0		2.1				
Intersection Summary												
HCM 6th Ctrl Delay				43.8								
HCM 6th LOS				D								

2021 Traffic Counts

AM and PM peak hours for counts used for traffic analysis, PM or daily only for comparison locations between 2019 and 2021

LOCATION: 8th Ave -- Fulton St
CITY/STATE: San Francisco, CA

QC JOB #: 15592511
DATE: Thu, Oct 14 2021

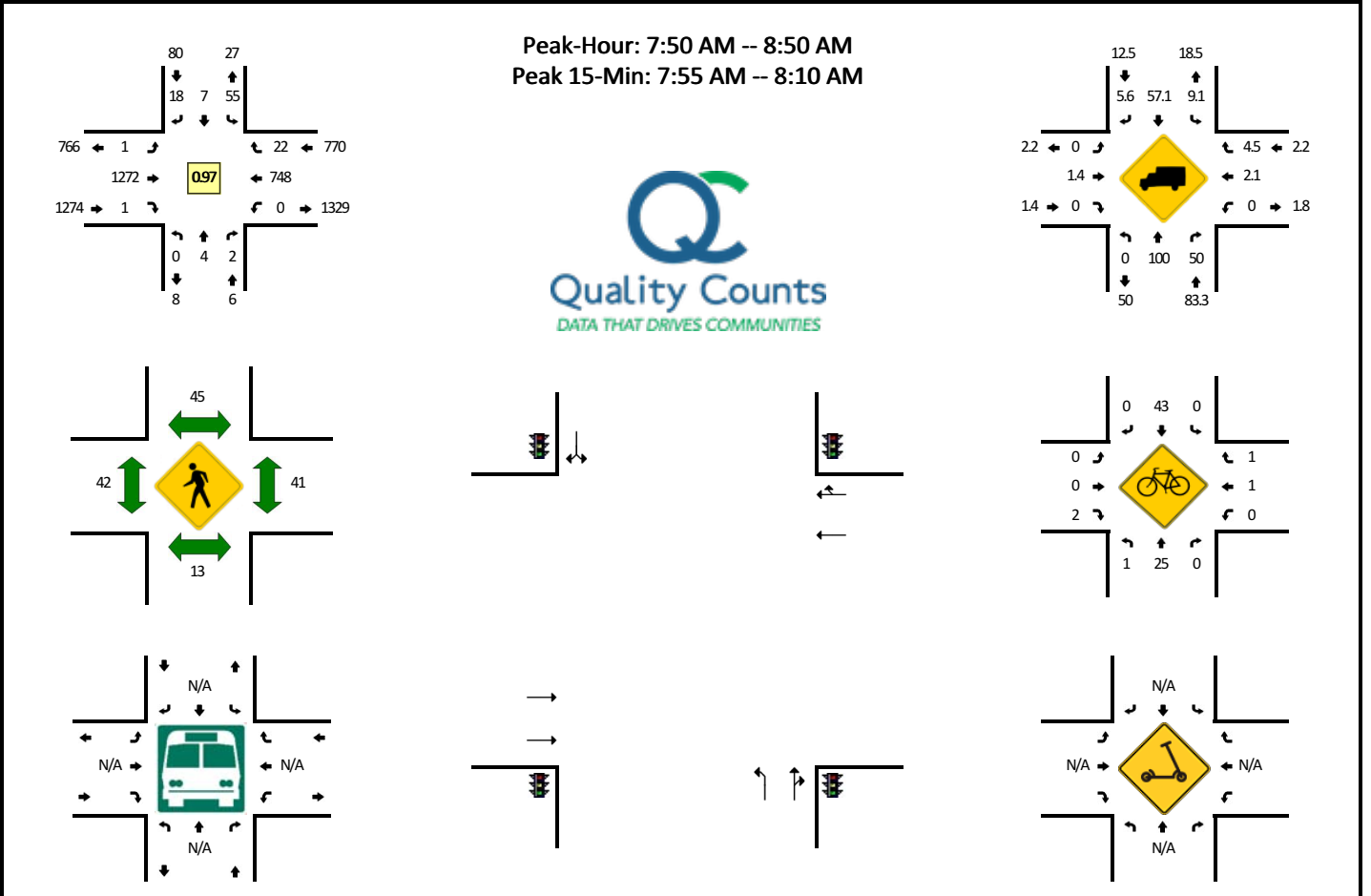

5-Min Count Period Beginning At	8th Ave (Northbound)				8th Ave (Southbound)				Fulton St (Eastbound)				Fulton St (Westbound)				Total	Hourly Totals
	Left	Thru	Right	U	Left	Thru	Right	U	Left	Thru	Right	U	Left	Thru	Right	U		
7:00 AM	0	0	0	0	3	1	0	0	0	54	0	0	0	27	2	0	87	
7:05 AM	0	1	0	0	3	0	0	0	0	53	0	0	0	33	0	0	90	
7:10 AM	1	1	0	0	4	0	0	0	1	86	0	0	0	52	0	0	145	
7:15 AM	0	0	0	0	6	0	0	0	0	68	0	0	0	35	2	0	111	
7:20 AM	0	0	0	0	2	1	1	0	0	69	0	0	0	34	2	0	109	
7:25 AM	0	0	0	0	6	0	0	0	0	100	0	0	0	44	1	0	151	
7:30 AM	0	1	0	0	5	0	0	0	0	71	0	0	0	39	2	0	118	
7:35 AM	0	1	1	0	5	1	1	0	0	79	0	0	1	56	3	0	148	
7:40 AM	0	0	0	0	6	0	1	0	0	114	0	0	2	61	0	0	184	
7:45 AM	0	0	0	0	2	3	1	0	1	105	0	0	0	63	0	0	175	
7:50 AM	0	0	1	0	5	1	3	0	0	93	0	0	0	53	1	0	157	
7:55 AM	0	0	0	0	4	0	1	0	0	132	0	0	0	64	1	0	202	
8:00 AM	0	1	0	0	1	1	2	0	0	110	1	0	0	67	3	0	186	
8:05 AM	0	1	0	0	12	0	0	0	0	98	0	0	0	50	1	0	162	
8:10 AM	0	0	0	0	4	1	0	0	0	124	0	0	0	60	2	0	191	
8:15 AM	0	0	0	0	6	0	1	0	1	106	0	0	0	47	4	0	165	
8:20 AM	0	0	0	0	6	0	1	0	0	97	0	0	0	59	2	0	165	
8:25 AM	0	0	0	0	1	0	1	0	0	116	0	0	0	81	0	0	199	
8:30 AM	0	0	1	0	6	1	1	0	0	83	0	0	0	74	3	0	169	
8:35 AM	0	1	0	0	4	1	3	0	0	88	0	0	0	62	1	0	160	
8:40 AM	0	1	0	0	1	1	2	0	0	112	0	0	0	74	3	0	194	
8:45 AM	0	0	0	0	5	1	3	0	0	113	0	0	0	57	1	0	180	
8:50 AM	0	1	1	0	3	2	2	0	1	93	0	0	0	54	0	0	157	
8:55 AM	0	1	1	0	5	0	0	0	0	94	0	0	0	67	4	0	172	
Peak 15-Min Flowrates	Northbound				Southbound				Eastbound				Westbound				Total	
	Left	Thru	Right	U	Left	Thru	Right	U	Left	Thru	Right	U	Left	Thru	Right	U		
All Vehicles	0	8	0	0	68	4	12	0	0	1360	4	0	0	724	20	0	2200	
Heavy Trucks	0	8	0	0	8	4	0	0	0	12	0	0	0	16	0	0	48	
Buses																		
Pedestrians		12				56				28				36			132	
Bicycles	0	20	0		0	60	0		0	0	0		0	0	0		80	
Scoters																		

Comments:

LOCATION: 8th Ave -- Fulton St
CITY/STATE: San Francisco, CA

QC JOB #: 15592512
DATE: Thu, Oct 14 2021

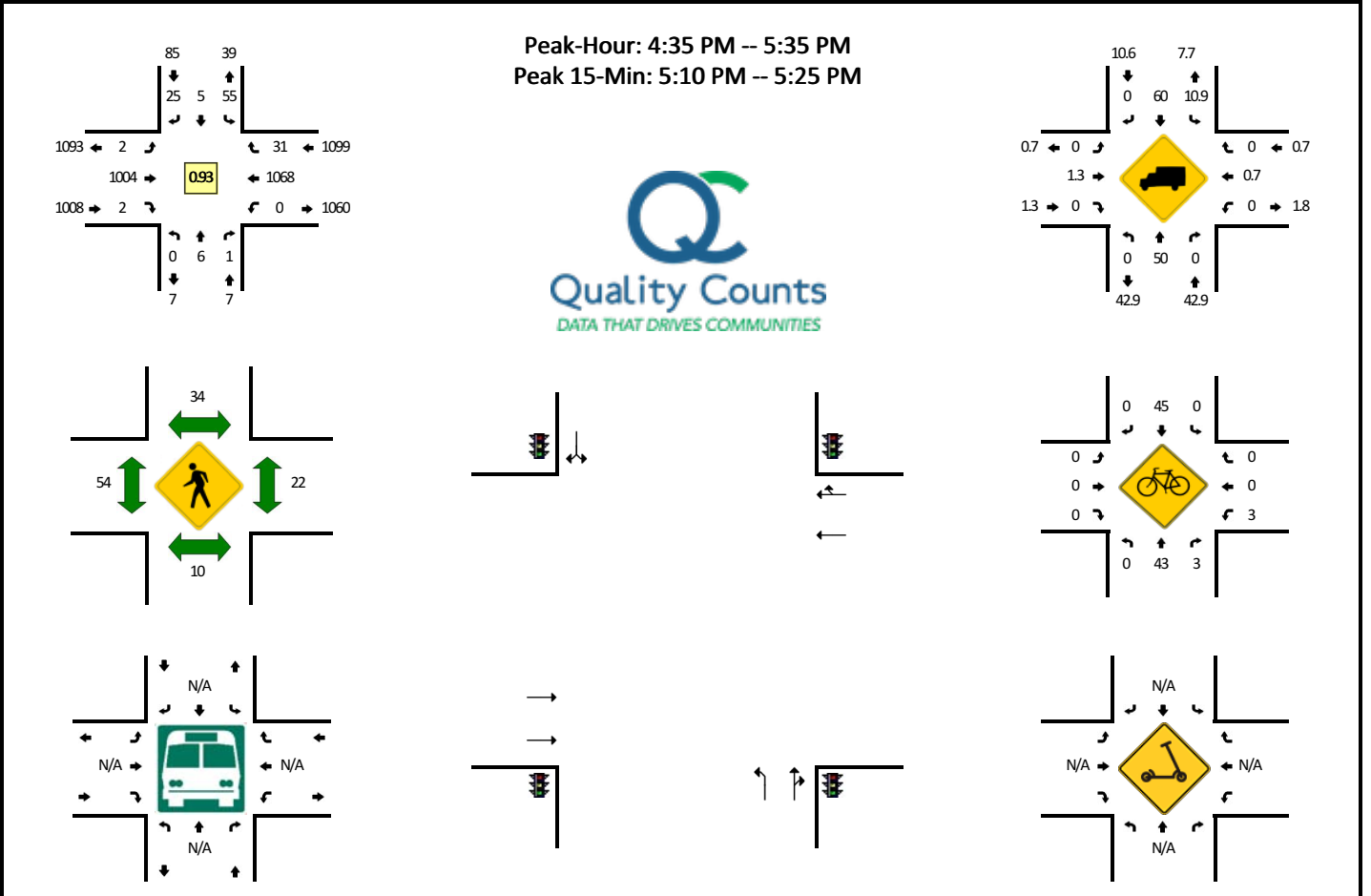

5-Min Count Period Beginning At	8th Ave (Northbound)				8th Ave (Southbound)				Fulton St (Eastbound)				Fulton St (Westbound)				Total	Hourly Totals
	Left	Thru	Right	U	Left	Thru	Right	U	Left	Thru	Right	U	Left	Thru	Right	U		
4:00 PM	0	0	0	0	2	0	3	0	0	64	0	1	0	100	3	0	173	
4:05 PM	0	0	0	0	4	0	0	0	0	76	0	0	0	84	2	0	166	
4:10 PM	0	2	0	0	2	0	1	0	0	86	0	0	0	97	2	0	190	
4:15 PM	1	1	0	0	1	0	0	0	0	70	0	0	0	70	1	0	144	
4:20 PM	0	0	0	0	5	1	0	0	0	81	0	0	0	93	1	0	181	
4:25 PM	0	0	0	0	5	0	1	0	0	85	0	0	0	91	4	0	186	
4:30 PM	0	2	0	0	5	0	4	0	1	74	0	0	0	82	1	0	169	
4:35 PM	0	0	0	0	2	1	1	0	0	82	1	0	0	89	2	0	178	
4:40 PM	0	1	0	0	4	0	0	0	1	100	0	0	0	88	1	0	195	
4:45 PM	0	1	0	0	6	1	2	0	0	68	1	0	0	82	1	0	162	
4:50 PM	0	0	0	0	5	1	0	0	0	78	0	0	0	79	1	0	164	
4:55 PM	0	0	0	0	5	0	3	0	0	87	0	0	0	91	3	0	189	
5:00 PM	0	0	1	0	5	0	2	0	0	65	0	0	0	87	1	0	161	2097
5:05 PM	0	2	0	0	10	1	1	0	0	79	0	0	0	67	5	0	165	2085
5:10 PM	0	0	0	0	3	0	4	0	1	108	0	0	0	102	4	0	222	2116
5:15 PM	0	0	0	0	4	0	5	0	0	93	0	0	0	83	4	0	189	2161
5:20 PM	0	0	0	0	5	1	0	0	0	86	0	0	0	87	3	0	182	2162
5:25 PM	0	0	0	0	2	0	3	0	0	88	0	0	0	116	5	0	214	2190
5:30 PM	0	2	0	0	4	0	4	0	0	70	0	0	0	97	1	0	178	2199
5:35 PM	0	0	0	0	2	1	2	0	0	68	0	0	0	83	2	0	158	2179
5:40 PM	0	0	0	0	3	0	1	0	0	84	0	0	0	96	1	0	185	2169
5:45 PM	0	2	0	0	3	1	1	0	0	86	0	0	0	78	5	0	176	2183
5:50 PM	0	2	0	0	6	0	1	0	1	65	0	0	0	77	1	0	153	2172
5:55 PM	0	0	0	0	2	0	1	0	0	71	0	0	0	89	1	0	164	2147
Peak 15-Min Flowrates	Northbound				Southbound				Eastbound				Westbound				Total	
	Left	Thru	Right	U	Left	Thru	Right	U	Left	Thru	Right	U	Left	Thru	Right	U		
All Vehicles	0	0	0	0	48	4	36	0	4	1148	0	0	0	1088	44	0	2372	
Heavy Trucks	0	0	0	0	4	4	0	0	0	8	0	0	0	0	0	0	16	
Buses																		
Pedestrians		12				28				52				20			112	
Bicycles	0	56	4		0	68	0		0	0	0		4	0	0	132		
Scooters																		

Comments:

LOCATION: 9th Ave -- Lincoln Wy
CITY/STATE: San Francisco, CA

QC JOB #: 15592515
DATE: Thu, Oct 14 2021

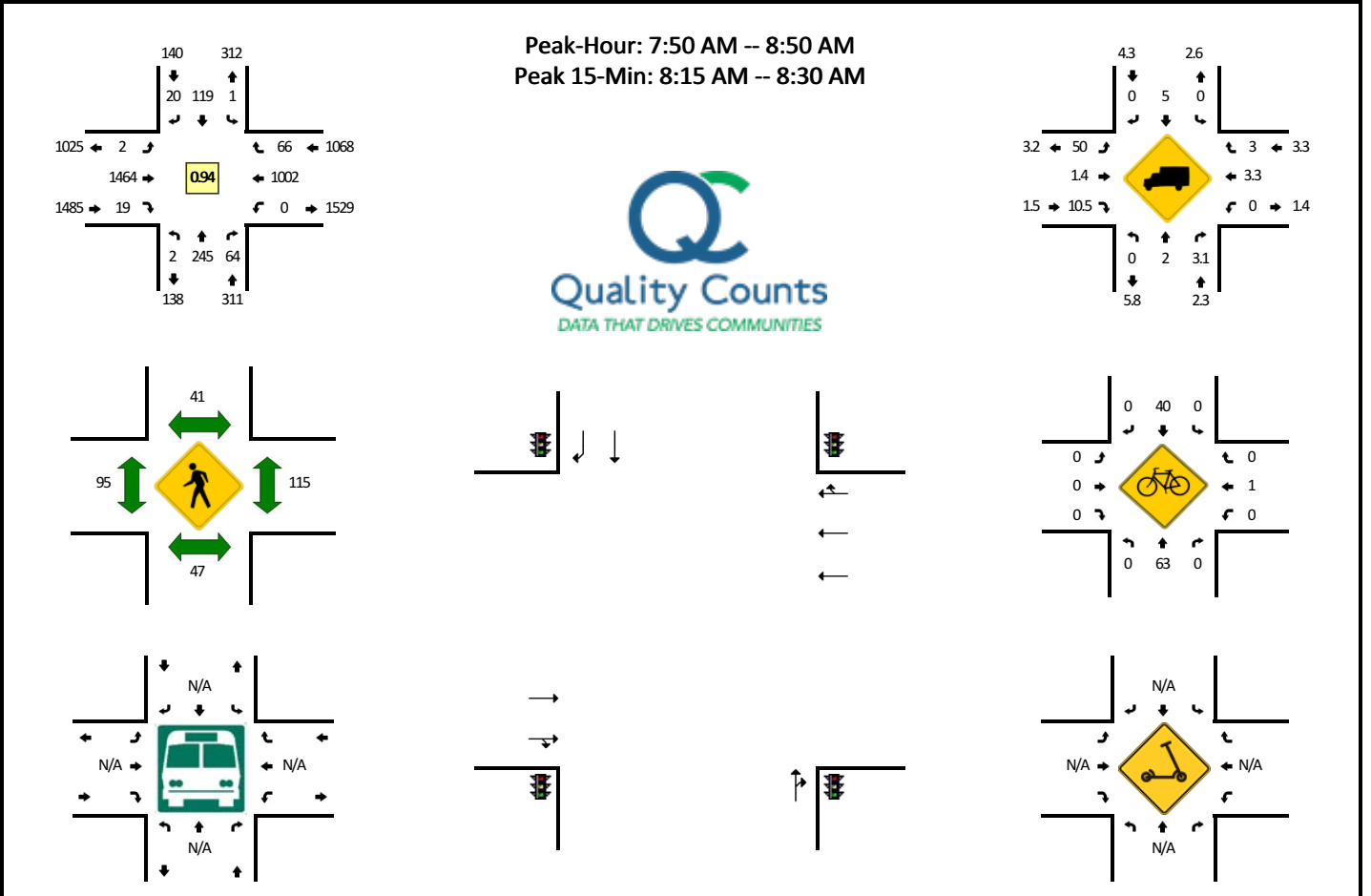

5-Min Count Period Beginning At	9th Ave (Northbound)				9th Ave (Southbound)				Lincoln Wy (Eastbound)				Lincoln Wy (Westbound)				Total	Hourly Totals
	Left	Thru	Right	U	Left	Thru	Right	U	Left	Thru	Right	U	Left	Thru	Right	U		
7:00 AM	1	10	4	0	0	4	2	0	0	75	0	0	0	26	2	0	124	
7:05 AM	0	10	2	0	2	5	0	0	0	67	0	0	0	33	6	0	125	
7:10 AM	1	6	3	0	0	0	0	0	0	86	7	0	0	45	1	0	149	
7:15 AM	0	5	3	0	0	2	0	0	0	100	3	0	0	30	2	0	145	
7:20 AM	0	9	3	0	0	7	1	0	0	98	1	0	0	37	2	0	158	
7:25 AM	1	8	6	0	0	5	0	0	0	100	2	0	0	45	6	0	173	
7:30 AM	0	6	4	0	0	3	1	0	0	105	4	0	0	52	4	0	179	
7:35 AM	0	13	3	0	0	4	0	0	0	117	1	0	0	61	9	0	208	
7:40 AM	1	23	5	0	0	9	0	0	0	102	0	0	0	56	2	0	198	
7:45 AM	0	16	10	0	0	5	0	0	0	123	3	0	0	86	7	0	250	
7:50 AM	0	14	5	0	0	8	3	0	0	127	1	0	0	79	4	0	241	
7:55 AM	0	15	5	0	0	7	1	0	0	112	1	0	0	69	2	0	212	2162
8:00 AM	0	32	1	0	1	12	3	0	0	126	4	0	0	62	7	0	248	2286
8:05 AM	0	13	8	0	0	15	1	0	0	130	1	0	0	76	7	0	251	2412
8:10 AM	1	15	5	0	0	9	0	0	1	149	0	0	0	69	4	0	253	2516
8:15 AM	1	18	10	0	0	13	2	0	0	127	1	0	0	97	2	0	271	2642
8:20 AM	0	32	3	0	0	8	0	0	0	101	0	0	0	86	6	0	236	2720
8:25 AM	0	21	4	0	0	14	1	0	0	138	2	0	0	101	8	0	289	2836
8:30 AM	0	28	9	0	0	9	5	0	0	122	1	0	0	86	6	0	266	2923
8:35 AM	0	24	1	0	0	7	1	0	0	105	2	0	0	85	7	0	232	2947
8:40 AM	0	21	6	0	0	9	2	0	0	116	2	1	0	90	4	0	251	3000
8:45 AM	0	12	7	0	0	8	1	0	0	111	4	0	0	102	9	0	254	3004
8:50 AM	1	23	2	0	0	19	2	0	0	96	1	0	0	84	10	0	238	3001
8:55 AM	1	18	8	0	0	7	1	0	1	97	3	0	0	65	5	0	206	2995
Peak 15-Min Flowrates	Northbound				Southbound				Eastbound				Westbound				Total	
	Left	Thru	Right	U	Left	Thru	Right	U	Left	Thru	Right	U	Left	Thru	Right	U		
All Vehicles	4	284	68	0	0	140	12	0	0	1464	12	0	0	1136	64	0	3184	
Heavy Trucks	0	0	4		0	8	0		0	28	0		0	44	0		84	
Buses																		
Pedestrians		32				32				104				156			324	
Bicycles	0	116	0		0	16	0		0	0	0		0	0	0		132	
Scoters																		

Comments:

LOCATION: 9th Ave -- Lincoln Wy
CITY/STATE: San Francisco, CA

QC JOB #: 15592516
DATE: Thu, Oct 14 2021

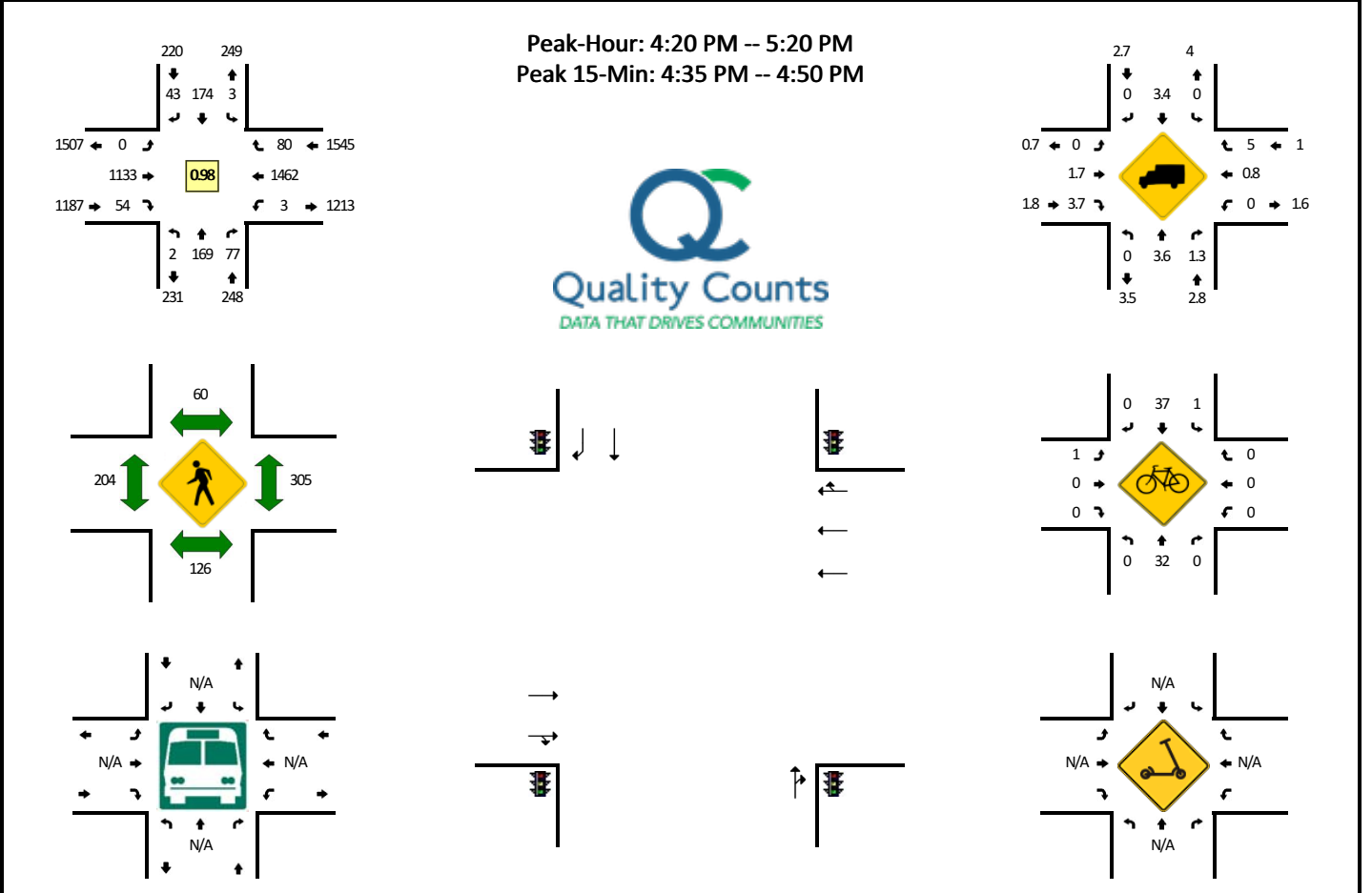

5-Min Count Period Beginning At	9th Ave (Northbound)				9th Ave (Southbound)				Lincoln Wy (Eastbound)				Lincoln Wy (Westbound)				Total	Hourly Totals
	Left	Thru	Right	U	Left	Thru	Right	U	Left	Thru	Right	U	Left	Thru	Right	U		
4:00 PM	0	13	1	0	0	15	3	0	0	87	5	0	0	129	5	0	258	
4:05 PM	0	22	6	0	0	8	2	0	0	85	1	0	0	128	6	0	258	
4:10 PM	0	19	4	0	0	15	4	0	0	87	0	0	1	125	6	0	261	
4:15 PM	1	15	5	0	0	15	2	0	0	96	4	0	0	106	1	0	245	
4:20 PM	0	6	6	0	0	16	2	0	0	114	1	0	0	132	4	0	281	
4:25 PM	0	13	12	0	0	17	1	0	0	105	3	0	0	117	7	0	275	
4:30 PM	0	17	7	0	1	14	2	0	0	88	1	0	0	109	9	0	248	
4:35 PM	0	19	7	0	0	14	6	0	0	89	6	0	0	115	6	0	262	
4:40 PM	0	15	7	0	1	9	1	0	0	80	5	0	0	150	8	0	276	
4:45 PM	0	18	5	0	0	20	2	0	0	89	7	0	0	122	12	0	275	
4:50 PM	1	14	9	0	0	15	5	0	0	101	8	0	2	100	3	0	258	
4:55 PM	0	17	5	0	0	16	4	0	0	104	4	0	0	121	5	0	276	3173
5:00 PM	0	7	4	0	0	13	3	0	0	90	2	0	0	130	6	0	255	3170
5:05 PM	0	22	5	0	0	13	6	0	0	88	7	0	0	111	4	0	256	3168
5:10 PM	1	17	4	0	1	17	4	0	0	80	5	0	0	116	6	0	251	3158
5:15 PM	0	4	6	0	0	10	7	0	0	105	5	0	1	139	10	0	287	3200
5:20 PM	0	19	3	0	0	12	3	0	0	94	7	0	0	117	6	0	261	3180
5:25 PM	0	11	13	0	0	10	7	0	0	91	4	0	0	108	3	0	247	3152
5:30 PM	1	19	10	0	0	8	7	0	0	87	8	0	0	106	7	0	253	3157
5:35 PM	0	3	2	0	0	12	4	0	0	70	10	0	0	139	6	0	246	3141
5:40 PM	1	14	9	0	0	17	5	0	0	79	8	0	1	119	8	0	261	3126
5:45 PM	1	11	7	0	0	16	11	0	0	81	12	0	0	101	3	0	243	3094
5:50 PM	0	12	7	0	0	21	5	0	0	75	7	0	0	123	7	0	257	3093
5:55 PM	1	8	4	0	1	6	5	0	0	94	5	0	0	126	9	0	259	3076
Peak 15-Min Flowrates	Northbound				Southbound				Eastbound				Westbound				Total	
	Left	Thru	Right	U	Left	Thru	Right	U	Left	Thru	Right	U	Left	Thru	Right	U		
All Vehicles	0	208	76	0	4	172	36	0	0	1032	72	0	0	1548	104	0	3252	
Heavy Trucks	0	4	0		0	8	0		0	16	0		0	8	0		36	
Buses																		
Pedestrians		96				56				208				276			636	
Bicycles	0	28	0		0	36	0		4	0	0		0	0	0		68	
Scoters																		

Comments:

LOCATION: Martin Luther King Jr Dr -- Nancy Pelosi Dr
CITY/STATE: San Francisco, CA

QC JOB #: 15592517
DATE: Thu, Oct 14 2021

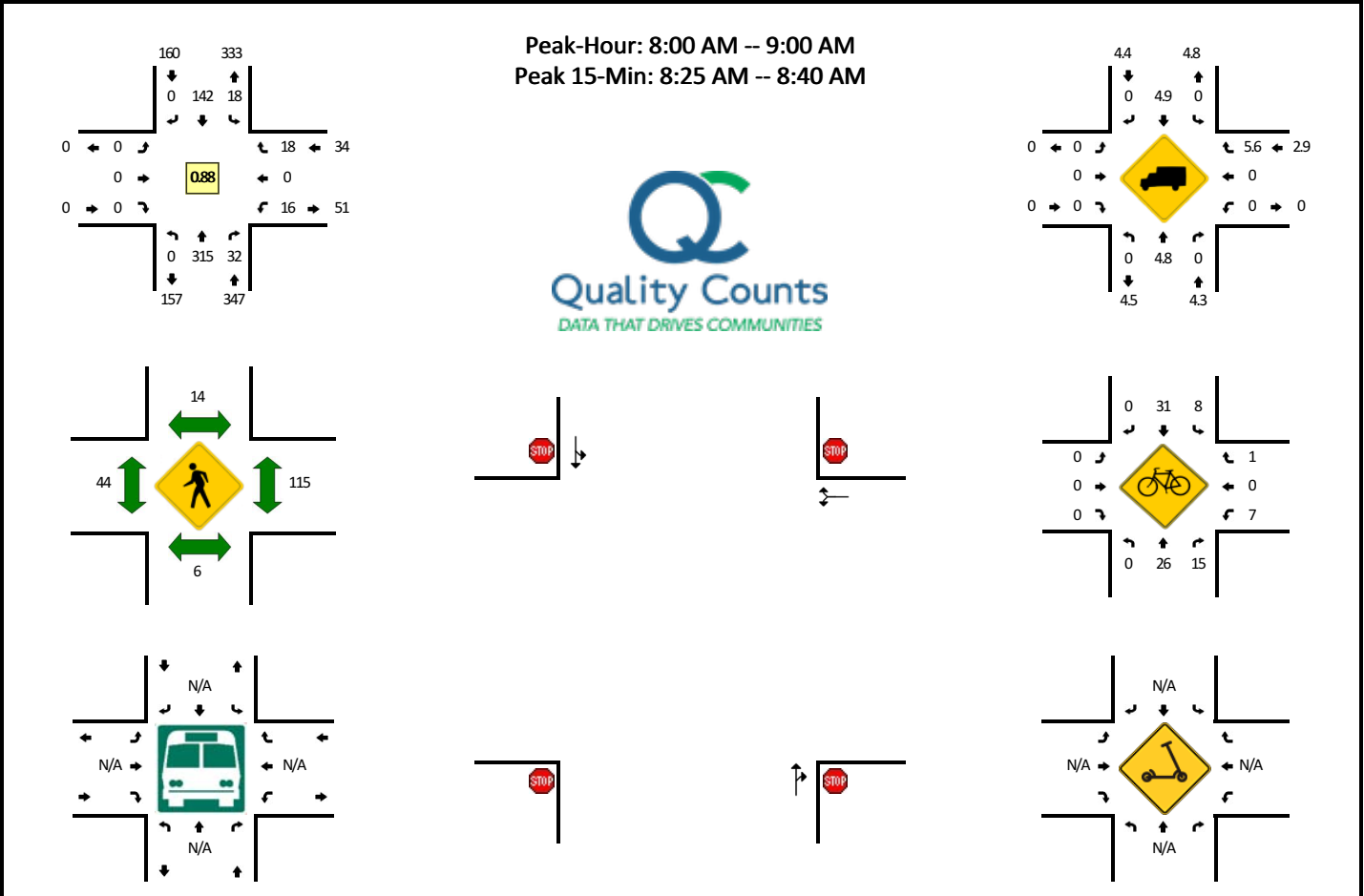

5-Min Count Period Beginning At	Martin Luther King Jr Dr (Northbound)				Martin Luther King Jr Dr (Southbound)				Nancy Pelosi Dr (Eastbound)				Nancy Pelosi Dr (Westbound)				Total	Hourly Totals
	Left	Thru	Right	U	Left	Thru	Right	U	Left	Thru	Right	U	Left	Thru	Right	U		
7:00 AM	0	10	3	0	3	8	0	0	0	0	0	0	1	0	0	0	25	
7:05 AM	0	10	6	0	3	5	0	0	0	0	0	0	1	0	2	0	27	
7:10 AM	0	9	1	0	1	3	0	0	0	0	0	0	0	0	4	0	18	
7:15 AM	0	7	3	0	2	4	0	0	0	0	0	0	0	0	0	0	16	
7:20 AM	0	9	1	0	2	7	0	0	0	0	0	0	0	0	1	0	20	
7:25 AM	0	12	2	0	0	5	0	0	0	0	0	0	0	0	0	0	19	
7:30 AM	0	5	2	0	0	5	0	0	0	0	0	0	1	0	0	0	13	
7:35 AM	0	20	1	0	0	2	0	0	0	0	0	0	0	0	0	0	23	
7:40 AM	0	25	1	1	1	7	0	0	0	0	0	0	1	0	0	0	36	
7:45 AM	0	17	2	0	2	8	0	0	0	0	0	0	0	0	2	0	31	
7:50 AM	0	18	3	0	1	13	0	0	0	0	0	0	1	0	1	0	37	
7:55 AM	0	12	2	0	0	12	0	0	0	0	0	0	0	0	2	0	28	293
8:00 AM	0	35	4	0	1	13	0	0	0	0	0	0	2	0	0	0	55	323
8:05 AM	0	21	3	0	2	15	0	0	0	0	0	0	1	0	4	0	46	342
8:10 AM	0	19	1	0	3	13	0	0	0	0	0	0	1	0	2	0	39	363
8:15 AM	0	20	1	0	1	12	0	0	0	0	0	0	1	0	0	0	35	382
8:20 AM	0	30	1	0	0	9	0	0	0	0	0	0	1	0	0	0	41	403
8:25 AM	0	31	7	0	2	20	0	0	0	0	0	0	0	0	2	0	62	446
8:30 AM	0	31	1	0	0	10	0	0	0	0	0	0	1	0	1	1	45	478
8:35 AM	0	31	1	0	2	7	0	0	0	0	0	0	1	0	4	0	46	501
8:40 AM	0	21	6	0	1	9	0	0	0	0	0	0	2	0	1	0	40	505
8:45 AM	0	25	1	0	1	10	0	0	0	0	0	0	2	0	0	0	39	513
8:50 AM	0	26	4	0	2	14	0	0	0	0	0	0	2	0	2	0	50	526
8:55 AM	0	25	2	0	3	10	0	0	0	0	0	0	1	0	2	0	43	541
Peak 15-Min Flowrates	Northbound				Southbound				Eastbound				Westbound				Total	
	Left	Thru	Right	U	Left	Thru	Right	U	Left	Thru	Right	U	Left	Thru	Right	U		
All Vehicles	0	372	36	0	16	148	0	0	0	0	0	0	8	0	28	4	612	
Heavy Trucks	0	4	0		0	8	0		0	0	0		0	0	0		12	
Buses																		
Pedestrians		4				20				60				100			184	
Bicycles	0	16	28		8	32	0		0	0	0		4	0	0		88	
Scoters																		

Comments:

LOCATION: Martin Luther King Jr Dr -- Nancy Pelosi Dr
CITY/STATE: San Francisco, CA

QC JOB #: 15592518
DATE: Thu, Oct 14 2021

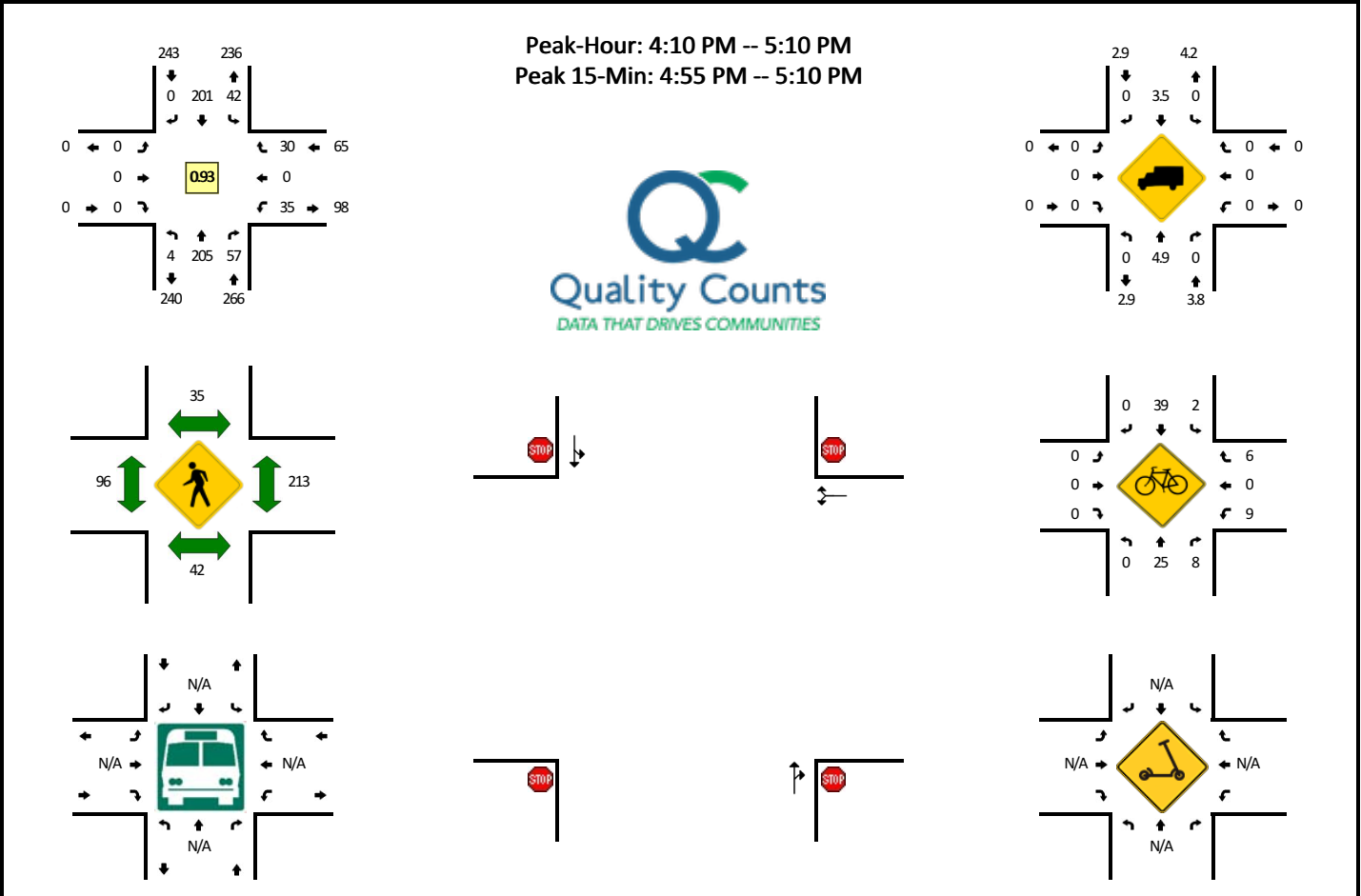

5-Min Count Period Beginning At	Martin Luther King Jr Dr (Northbound)				Martin Luther King Jr Dr (Southbound)				Nancy Pelosi Dr (Eastbound)				Nancy Pelosi Dr (Westbound)				Total	Hourly Totals
	Left	Thru	Right	U	Left	Thru	Right	U	Left	Thru	Right	U	Left	Thru	Right	U		
4:00 PM	0	23	4	0	2	23	0	0	0	0	0	0	1	0	6	0	59	
4:05 PM	0	26	1	0	3	14	0	0	0	0	0	0	3	0	4	0	51	
4:10 PM	0	19	3	0	5	19	0	0	0	0	0	0	4	0	4	0	54	
4:15 PM	0	6	1	0	6	16	0	0	0	0	0	0	4	0	3	0	36	
4:20 PM	0	13	5	0	3	18	0	1	0	0	0	0	2	0	1	0	43	
4:25 PM	0	17	6	0	3	17	0	0	0	0	0	0	3	0	1	0	47	
4:30 PM	0	24	6	0	1	14	0	0	0	0	0	0	3	0	4	0	52	
4:35 PM	0	18	4	2	6	16	0	0	0	0	0	0	1	0	3	0	50	
4:40 PM	0	20	4	1	3	16	0	0	0	0	0	0	5	0	1	0	50	
4:45 PM	0	22	6	1	3	11	0	0	0	0	0	0	2	0	0	0	45	
4:50 PM	0	15	7	0	3	14	0	0	0	0	0	0	2	0	2	0	43	
4:55 PM	0	12	4	0	3	23	0	0	0	0	0	0	0	0	1	0	43	573
5:00 PM	0	15	8	0	4	19	0	0	0	0	0	0	3	0	6	0	55	569
5:05 PM	0	24	3	0	1	18	0	0	0	0	0	0	6	0	4	0	56	574
5:10 PM	0	14	3	0	1	20	0	0	0	0	0	0	2	0	3	0	43	563
5:15 PM	0	14	1	1	6	12	0	0	0	0	0	0	1	0	4	0	39	566
5:20 PM	0	20	1	0	3	17	0	0	0	0	0	0	4	0	1	0	46	569
5:25 PM	0	17	5	0	5	15	0	0	0	0	0	0	4	0	4	0	50	572
5:30 PM	0	23	0	0	1	13	0	0	0	0	0	0	1	0	4	0	42	562
5:35 PM	0	15	1	1	4	14	0	0	0	0	0	0	0	0	3	0	38	550
5:40 PM	0	22	3	0	5	16	0	1	0	0	0	0	3	0	8	0	58	558
5:45 PM	0	15	4	1	2	25	0	0	0	0	0	0	3	0	3	0	53	566
5:50 PM	0	18	4	1	1	16	0	0	0	0	0	0	2	0	2	0	44	567
5:55 PM	0	15	8	0	1	12	0	0	0	0	0	0	2	0	7	0	45	569
Peak 15-Min Flowrates	Northbound				Southbound				Eastbound				Westbound				Total	
	Left	Thru	Right	U	Left	Thru	Right	U	Left	Thru	Right	U	Left	Thru	Right	U		
All Vehicles	0	204	60	0	32	240	0	0	0	0	0	0	36	0	44	0	616	
Heavy Trucks	0	12	0	0	0	0	0	0	0	0	0	0	0	0	0	0	12	
Buses																		
Pedestrians		16				48				88				256			408	
Bicycles	0	20	8		4	76	0			0	0		12	0	4		124	
Scoters																		

Comments:

LOCATION: Stanyan St -- JFK Dr/Fell St/Oak St
CITY/STATE: San Francisco, CA

QC JOB #: 15592508
DATE: Thu, Oct 14 2021

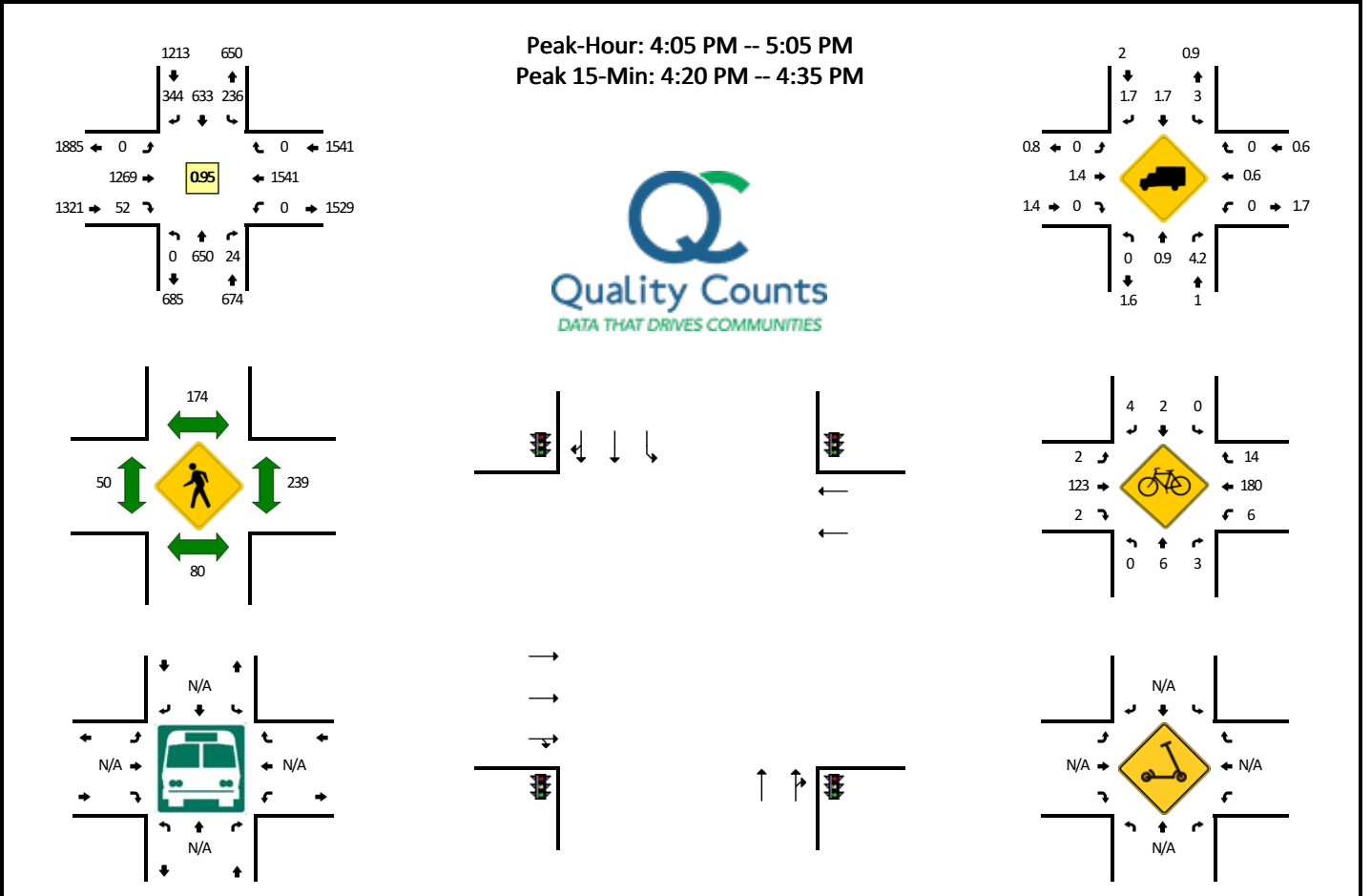

5-Min Count Period Beginning At	Stanyan St (Northbound)				Stanyan St (Southbound)				JFK Dr/Fell St/Oak St (Eastbound)				JFK Dr/Fell St/Oak St (Westbound)				Total	Hourly Totals
	Left	Thru	Right	U	Left	Thru	Right	U	Left	Thru	Right	U	Left	Thru	Right	U		
4:00 PM	0	47	1	0	17	55	27	0	0	74	3	0	7	120	0	0	351	
4:05 PM	0	53	2	0	19	65	32	0	0	84	2	0	0	118	0	0	375	
4:10 PM	0	51	2	0	17	44	31	0	0	101	4	0	0	140	0	0	390	
4:15 PM	0	51	4	0	19	48	30	0	0	112	5	0	0	127	0	0	396	
4:20 PM	0	58	3	0	24	71	31	0	0	113	4	0	0	116	0	0	420	
4:25 PM	0	49	1	0	16	43	25	0	0	133	5	0	0	149	0	0	421	
4:30 PM	0	58	1	0	21	54	25	0	0	107	9	0	0	131	0	0	406	
4:35 PM	0	66	0	0	23	49	28	0	0	88	2	0	0	118	0	0	374	
4:40 PM	0	50	0	0	15	43	29	0	0	125	4	0	0	139	0	0	405	
4:45 PM	0	62	3	0	20	47	28	0	0	94	4	0	0	127	0	0	385	
4:50 PM	0	57	0	0	24	61	27	0	0	84	4	0	0	112	0	0	369	
4:55 PM	0	49	4	0	16	52	28	0	0	135	5	0	0	136	0	0	425	4717
5:00 PM	0	46	4	0	22	56	30	0	0	93	4	0	0	128	0	0	383	4749
5:05 PM	0	45	3	0	26	53	28	0	0	86	4	0	0	120	0	0	365	4739
5:10 PM	0	47	1	0	19	24	23	0	0	137	2	0	0	145	0	0	398	4747
5:15 PM	0	58	3	0	16	50	31	0	0	120	1	0	0	115	0	0	394	4745
5:20 PM	0	58	2	0	23	57	24	0	0	85	5	0	0	115	0	0	369	4694
5:25 PM	0	44	1	0	13	43	27	0	0	127	6	0	0	144	0	0	405	4678
5:30 PM	0	60	1	0	11	61	28	0	0	102	7	0	0	118	0	0	388	4660
5:35 PM	0	53	1	0	23	53	36	0	0	94	1	0	0	119	0	0	380	4666
5:40 PM	0	46	2	0	18	41	24	0	0	106	10	0	0	127	1	0	375	4636
5:45 PM	0	58	2	0	17	57	35	0	0	90	5	0	0	122	0	0	386	4637
5:50 PM	0	49	3	0	22	48	35	0	0	106	13	0	0	125	0	0	401	4669
5:55 PM	0	48	3	0	16	51	31	0	0	88	4	0	0	131	0	0	372	4616
Peak 15-Min Flowrates	Northbound				Southbound				Eastbound				Westbound				Total	
	Left	Thru	Right	U	Left	Thru	Right	U	Left	Thru	Right	U	Left	Thru	Right	U		
All Vehicles	0	660	20	0	244	672	324	0	0	1412	72	0	0	1584	0	0	4988	
Heavy Trucks	0	0	0	0	4	12	4	0	0	16	0	0	0	8	0	0	44	
Buses																		
Pedestrians		72				160				24				208			464	
Bicycles	0	12	0		0	4	4		0	108	8		4	204	8		352	
Scoters																		

Comments:

LOCATION: Stanyan St -- Fell St
CITY/STATE: San Francisco, CA

QC JOB #: 15592506
DATE: Thu, Oct 14 2021

Peak-Hour: 4:05 PM -- 5:05 PM
Peak 15-Min: 4:45 PM -- 5:00 PM

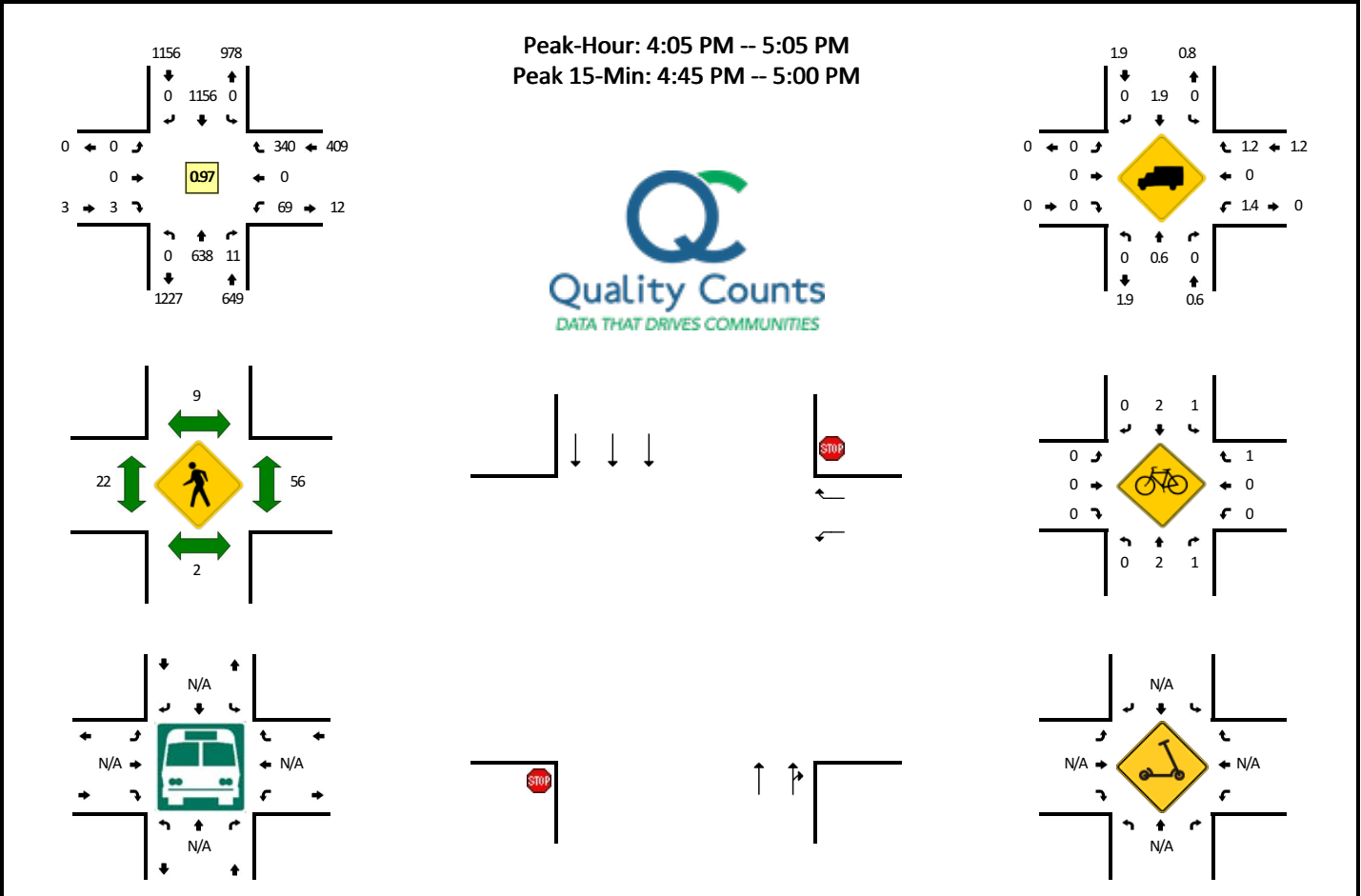

5-Min Count Period Beginning At	Stanyan St (Northbound)				Stanyan St (Southbound)				Fell St (Eastbound)				Fell St (Westbound)				Total	Hourly Totals	
	Left	Thru	Right	U	Left	Thru	Right	U	Left	Thru	Right	U	Left	Thru	Right	U			
4:00 PM	0	51	1	0	0	85	0	0	0	0	0	0	10	0	33	0	180		
4:05 PM	0	46	1	0	0	110	0	0	0	0	0	1	0	5	0	24	1	188	
4:10 PM	0	50	0	0	0	89	0	0	0	0	0	0	0	6	0	18	0	163	
4:15 PM	0	55	2	0	0	93	0	0	0	0	0	0	0	8	0	27	0	185	
4:20 PM	0	52	2	0	0	108	0	0	0	0	0	1	0	6	0	27	0	196	
4:25 PM	0	49	1	0	0	83	0	0	0	0	0	0	0	2	0	28	0	163	
4:30 PM	0	64	0	0	0	104	0	0	0	0	0	0	0	2	0	29	0	199	
4:35 PM	0	57	2	0	0	85	0	0	0	0	0	0	0	5	0	36	0	185	
4:40 PM	0	49	1	0	0	83	0	0	0	0	0	0	0	6	0	32	0	171	
4:45 PM	0	67	0	0	0	106	0	0	0	0	0	0	0	1	0	34	0	208	
4:50 PM	0	52	0	0	0	100	0	0	0	0	0	0	0	5	0	34	0	191	
4:55 PM	0	47	2	0	0	90	0	0	0	0	0	0	0	9	0	25	0	173	2202
5:00 PM	0	50	0	0	0	105	0	0	0	0	0	1	0	13	0	26	0	195	2217
5:05 PM	0	43	0	0	0	86	0	0	0	0	0	0	0	10	0	23	0	162	2191
5:10 PM	0	48	1	0	0	64	0	0	0	0	0	1	0	4	0	29	0	147	2175
5:15 PM	0	60	0	0	0	98	0	0	0	0	0	0	0	5	0	20	0	183	2173
5:20 PM	0	56	0	0	0	94	0	0	0	0	0	0	0	4	0	23	0	177	2154
5:25 PM	0	44	1	0	0	75	0	0	0	0	0	0	0	8	0	25	0	153	2144
5:30 PM	0	68	0	0	0	97	0	0	0	0	0	1	0	6	0	25	0	197	2142
5:35 PM	0	43	1	0	0	97	0	0	0	0	0	0	0	8	0	21	0	170	2127
5:40 PM	0	45	2	0	0	77	0	0	0	0	0	0	0	10	0	27	0	161	2117
5:45 PM	0	64	3	0	0	105	0	0	0	0	0	0	0	6	0	32	0	210	2119
5:50 PM	0	43	1	0	0	92	0	0	0	0	0	0	0	12	0	26	0	174	2102
5:55 PM	0	47	2	0	0	79	0	0	0	0	0	0	0	13	0	21	0	162	2091
Peak 15-Min Flowrates	Northbound				Southbound				Eastbound				Westbound				Total		
	Left	Thru	Right	U	Left	Thru	Right	U	Left	Thru	Right	U	Left	Thru	Right	U			
All Vehicles	0	664	8	0	0	1184	0	0	0	0	0	0	0	60	0	372	0	2288	
Heavy Trucks	0	4	0	0	0	28	0	0	0	0	0	0	0	0	0	4	0	36	
Buses																			
Pedestrians		8				16					36			60				120	
Bicycles	0	0	0		4	4	0			0	0	0	0	0	0			8	
Scoters																			

Comments:

LOCATION: Stanyan St -- Fulton St
CITY/STATE: San Francisco, CA

QC JOB #: 15592504
DATE: Thu, Oct 14 2021

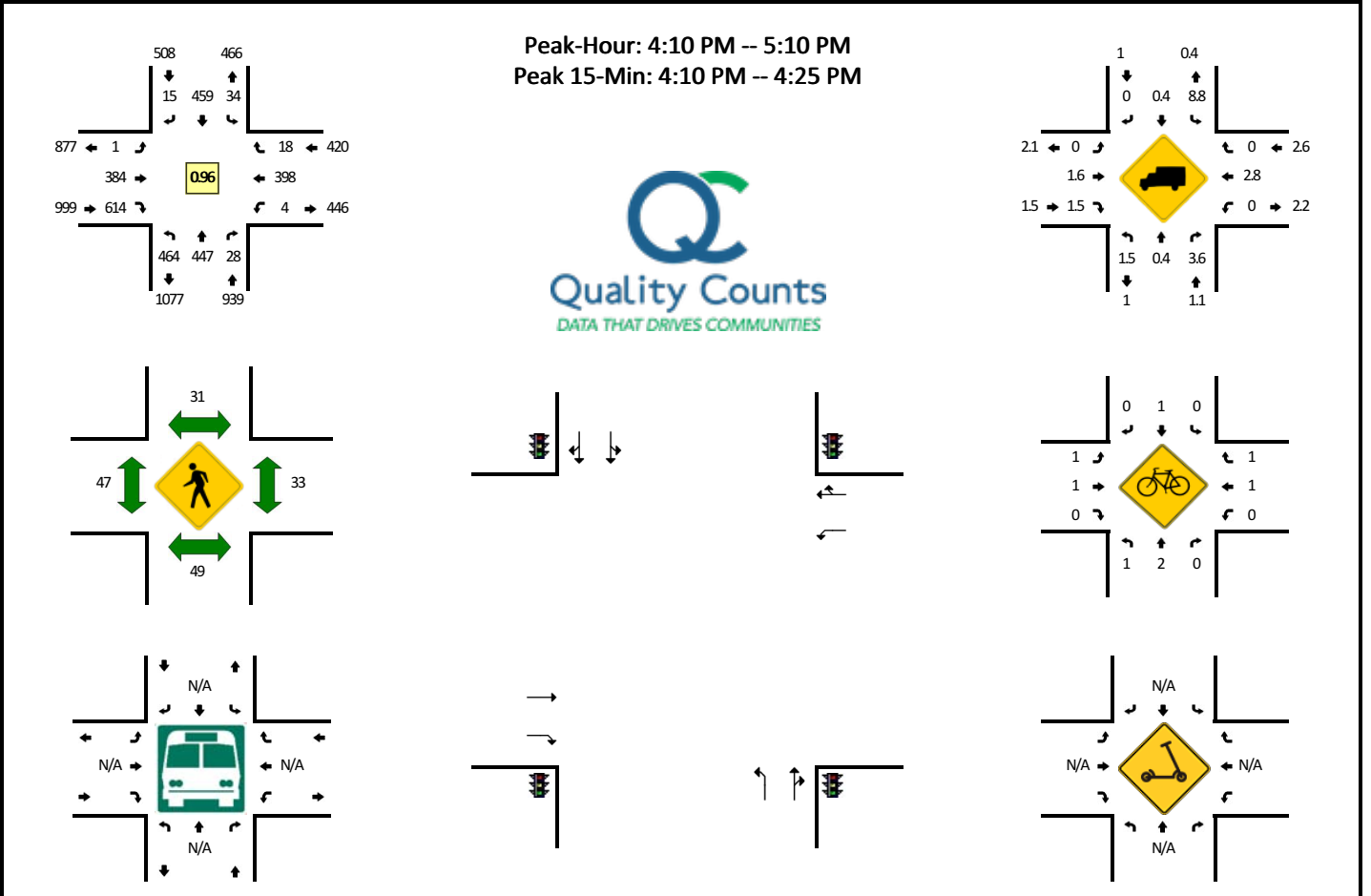

5-Min Count Period Beginning At	Stanyan St (Northbound)				Stanyan St (Southbound)				Fulton St (Eastbound)				Fulton St (Westbound)				Total	Hourly Totals
	Left	Thru	Right	U	Left	Thru	Right	U	Left	Thru	Right	U	Left	Thru	Right	U		
4:00 PM	45	37	4	0	2	40	0	0	0	26	48	0	0	43	6	0	251	
4:05 PM	31	27	5	0	0	39	0	0	0	38	28	0	0	36	4	0	208	
4:10 PM	38	40	1	0	1	35	1	0	0	37	48	0	0	34	4	0	239	
4:15 PM	44	39	1	0	3	51	0	0	0	35	51	0	0	33	1	0	258	
4:20 PM	33	33	0	0	0	46	3	0	0	35	46	0	0	54	1	0	251	
4:25 PM	41	36	4	0	2	34	0	0	1	30	59	0	0	32	0	0	239	
4:30 PM	43	41	3	0	4	42	0	0	0	26	44	0	0	22	2	0	227	
4:35 PM	34	37	2	0	3	41	1	0	0	33	52	0	0	38	4	0	245	
4:40 PM	42	36	4	0	4	22	1	0	0	36	44	0	0	30	1	0	220	
4:45 PM	41	45	1	0	1	38	1	0	0	32	59	0	0	23	2	0	243	
4:50 PM	33	31	3	0	3	36	2	0	0	43	49	0	0	33	2	0	235	
4:55 PM	40	39	6	0	3	38	2	0	0	32	52	0	2	31	1	0	246	
5:00 PM	41	39	2	0	4	40	2	0	0	25	55	0	0	35	0	0	243	2862
5:05 PM	34	31	1	0	6	36	2	0	0	20	55	0	2	33	0	0	220	2854
5:10 PM	43	34	4	0	2	32	2	0	0	32	43	0	1	40	4	0	237	2866
5:15 PM	42	34	3	0	2	36	0	0	0	21	37	0	0	31	3	0	209	2864
5:20 PM	34	25	5	0	4	24	0	0	0	43	39	0	0	43	2	0	219	2815
5:25 PM	39	39	2	0	1	35	0	0	1	35	36	0	0	45	5	0	238	2783
5:30 PM	37	35	3	0	3	45	0	0	0	33	45	0	0	40	1	0	232	2782
5:35 PM	36	31	3	0	3	39	0	0	0	40	48	0	1	34	0	0	235	2777
5:40 PM	41	36	2	0	0	35	0	0	0	31	45	0	0	24	2	0	216	2773
5:45 PM	46	32	2	0	2	44	0	0	0	32	41	0	0	28	2	0	229	2759
5:50 PM	33	31	3	0	2	43	0	0	0	39	48	0	1	33	2	0	235	2759
5:55 PM	41	33	1	0	1	28	0	0	0	36	53	0	0	29	1	0	223	2736
Peak 15-Min Flowrates	Northbound				Southbound				Eastbound				Westbound				Total	
	Left	Thru	Right	U	Left	Thru	Right	U	Left	Thru	Right	U	Left	Thru	Right	U		
All Vehicles	460	448	8	0	16	528	16	0	0	428	580	0	0	484	24	0	2992	
Heavy Trucks	8	0	0		4	4	0		0	4	8		0	12	0		40	
Buses																		
Pedestrians		64				28				40				52			184	
Bicycles	4	4	0		0	0	0		0	0	0		0	0	0		8	
Scoters																		

Comments:

Location/Site: 15592522 - Kezar Dr btwn Lincoln Wy & Stanyan St
 Data Collector (Name): Quality Counts

ADT Volume and Speed Summary

Site Characteristics		
FOR DATA COLLECTOR TO COMPLETE		
Location (primary street name)	Kezard Dr	
Between (minor street name)	John F Kennedy Dr	
And (minor street name)	Martin Luther King Jr Dr	
Direction 1	Northbound	
Direction 2	Southbound	
CNN of Location & Direction 1		
CNN of Location & Direction 2		
Time Period(s)	48 hrs	
Date Range (incl. days of week)		
Date Day 1 (date)	10/13/2021	Wednesday
Date Day 2 (date)	10/14/2021	Thursday
Date Day 3 (date)	N/A	

Distance Measurements		
Latitude / Longitude Location of Tube	37.7697472000	-122.4551888889
Speed Classification Data Available	Y N	

Analyze By	
Time Group:	Total Day
Xth Percentile:	25

Traffic Direction - N/W

ADT Volume and Speed Data											
Time Period		Vehicle Counts					Vehicle Speed				
Traffic Direction (N or W)	Date	ADT	% count w/out Speed	Exceed 20 mph	Exceed 30 mph	Exceed 40 mph	Mean	1 STDev	Median Speed	85th Percentile	25 th Percentile
Northbound	10/13/2021	15740	2.6%	83.2%	44.0%	1.9%	27.2	7.5	28	34	N/A
Northbound	10/14/2021	16159	2.9%	82.0%	42.1%	1.8%	26.8	7.6	28	34	N/A
Northbound	N/A	0	#DIV/0!	#DIV/0!	#DIV/0!	#DIV/0!	#DIV/0!	#DIV/0!	#N/A	#N/A	N/A
Summary (Average over # of days)											

Traffic Direction - S/E

ADT Volume and Speed Data											
Time Period		Vehicle Counts					Vehicle Speed				
Traffic Direction (N or W)	Date	ADT	% count w/out Speed	Exceed 20 mph	Exceed 30 mph	Exceed 40 mph	Mean Speed	1 STDev	Median Speed	85th Percentile	25 th Percentile
Southbound	10/13/2021	17214	1.5%	98.2%	32.6%	1.0%	28.0	4.6	28	33	N/A
Southbound	10/14/2021	17963	1.4%	98.5%	34.3%	1.5%	28.3	4.6	28	33	N/A
Southbound	N/A	0	#DIV/0!	#DIV/0!	#DIV/0!	#DIV/0!	#DIV/0!	#DIV/0!	#N/A	#N/A	N/A
Summary (Average over # of days)											

Pre-Pandemic Traffic Counts

PM or daily only for comparison locations between 2019 and 2021

LOCATION: 13. 8th Ave & Fulton St

QC JOB #: 15093026

CITY/STATE: San Francisco, CA



DATE: 10/22/2019

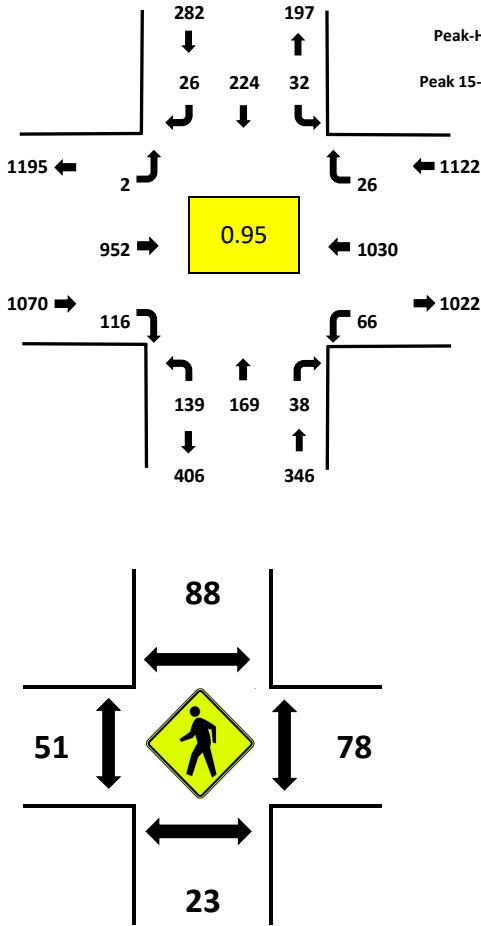

Peak-Hour: 5:00 PM - 6:00 PM
Peak 15-Min: 5:45 PM - 6:00 PM

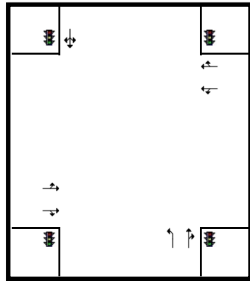
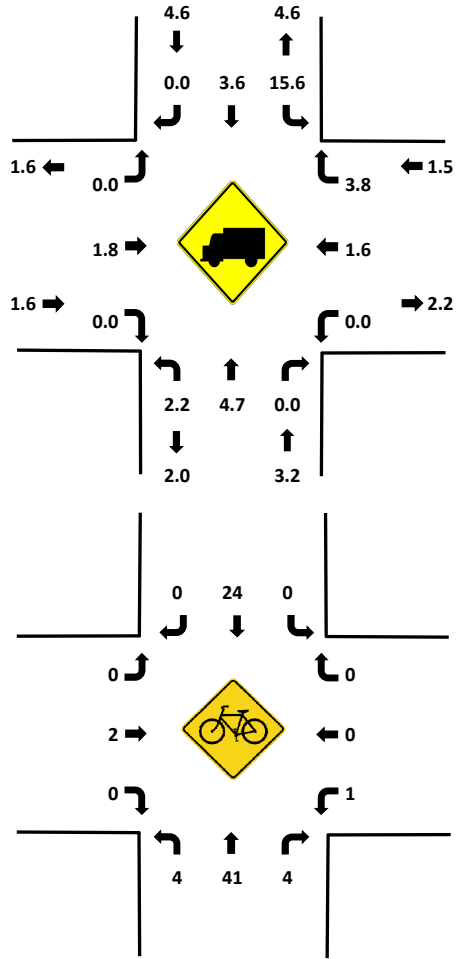

Count Period	13. 8th Ave Northbound				13. 8th Ave Southbound				Fulton St Eastbound				Fulton St Westbound				Total	Hourly Totals
	L	T	R	U	L	T	R	U	L	T	R	U	L	T	R	U		
4:00 PM	8	8	1	0	1	8	1	0	0	80	8	0	6	89	2	0	212	
4:05 PM	17	12	1	0	1	10	2	0	0	65	6	0	8	74	1	0	197	
4:10 PM	14	8	6	0	3	9	2	0	0	93	2	0	3	84	1	0	225	
4:15 PM	14	12	3	0	1	17	2	0	0	79	4	0	3	80	2	0	217	
4:20 PM	9	15	3	0	3	15	2	0	0	71	3	0	0	70	5	0	196	
4:25 PM	22	12	3	0	0	18	4	0	0	93	11	0	2	82	5	0	252	
4:30 PM	14	19	6	0	1	10	3	0	0	82	9	0	1	76	7	0	228	
4:35 PM	9	20	2	0	2	14	1	0	0	75	3	0	3	74	3	0	206	
4:40 PM	12	10	0	0	3	19	0	0	1	90	5	0	3	84	4	0	231	
4:45 PM	11	9	6	0	1	21	3	0	0	86	10	0	4	94	7	0	252	
4:50 PM	13	13	1	0	4	15	3	0	1	73	15	0	6	86	1	0	231	
4:55 PM	6	9	5	0	0	19	5	0	0	65	7	0	2	83	3	0	204	
5:00 PM	15	14	5	0	1	17	4	0	1	77	9	0	5	85	1	0	234	
5:05 PM	8	11	3	0	3	14	2	0	0	73	4	0	8	88	4	0	218	
5:10 PM	11	19	3	0	5	15	1	0	0	86	9	0	1	92	2	0	244	
5:15 PM	11	19	1	0	1	10	4	0	0	93	5	0	5	92	4	0	245	
5:20 PM	13	11	0	0	3	25	1	0	0	74	9	0	6	98	2	0	242	
5:25 PM	8	11	3	0	2	23	1	0	0	71	9	0	6	74	3	0	211	
5:30 PM	10	17	3	0	1	22	0	0	0	73	13	0	9	91	0	0	239	
5:35 PM	10	14	4	0	3	24	5	0	1	72	8	0	6	69	4	0	220	
5:40 PM	17	11	3	0	3	19	0	0	0	75	9	0	2	86	2	0	227	
5:45 PM	12	11	2	0	4	16	2	0	0	105	19	0	3	87	1	0	262	
5:50 PM	13	21	3	0	2	16	4	0	0	72	6	0	7	88	2	0	234	
5:55 PM	11	10	8	0	4	23	2	0	0	81	16	0	8	80	1	0	244	
Peak 15-Min Flowrates	NB				SB				EB				WB				Total	
	L	T	R	U	L	T	R	U	L	T	R	U	L	T	R	U		
All Vehicles	144	168	52	0	40	220	32	0	0	1032	164	0	72	1020	16	0	2960	
Heavies	4	8	0		4	8	0		0	20	0		0	16	0		60	
Peds		0				0				0				0			0	
Total Bikes	7	161	8		2	69	0		0	4	1		4	7	1		264	

Groups Printed- Vehicles Only

Start Time	9th AV Southbound				LINCOLN WY Westbound				9th AV Northbound				LINCOLN WY Eastbound				Int. Total
	RT	TH	LT	App. Total	RT	TH	LT	App. Total	RT	TH	LT	App. Total	RT	TH	LT	App. Total	
16:00	20	67	1	88	11	337	0	348	16	71	0	87	13	249	0	262	785
16:15	28	76	0	104	14	347	0	361	9	74	0	83	13	235	0	248	796
16:30	14	71	0	85	12	396	0	408	23	53	2	78	11	257	0	268	839
16:45	28	78	3	109	13	408	0	421	15	69	0	84	11	247	0	258	872
Total	90	292	4	386	50	1488	0	1538	63	267	2	332	48	988	0	1036	3292
17:00	24	68	0	92	21	410	0	431	19	48	0	67	10	260	0	270	860
17:15	36	68	0	104	18	426	0	444	9	60	0	69	17	240	0	257	874
17:30	38	87	0	125	15	439	0	454	25	67	0	92	7	271	0	278	949
17:45	27	71	0	98	18	448	0	466	16	60	1	77	9	250	0	259	900
Total	125	294	0	419	72	1723	0	1795	69	235	1	305	43	1021	0	1064	3583
Grand Total	215	586	4	805	122	3211	0	3333	132	502	3	637	91	2009	0	2100	6875
Apprch %	26.7	72.8	0.5		3.7	96.3	0		20.7	78.8	0.5		4.3	95.7	0		
Total %	3.1	8.5	0.1	11.7	1.8	46.7	0	48.5	1.9	7.3	0	9.3	1.3	29.2	0	30.5	

Start Time	9th AV Southbound				LINCOLN WY Westbound				9th AV Northbound				LINCOLN WY Eastbound				Int. Total
	RT	TH	LT	App. Total	RT	TH	LT	App. Total	RT	TH	LT	App. Total	RT	TH	LT	App. Total	
16:00	20	67	1	88	11	337	0	348	16	71	0	87	13	249	0	262	785
16:15	28	76	0	104	14	347	0	361	9	74	0	83	13	235	0	248	796
16:30	14	71	0	85	12	396	0	408	23	53	2	78	11	257	0	268	839
16:45	28	78	3	109	13	408	0	421	15	69	0	84	11	247	0	258	872
Total	90	292	4	386	50	1488	0	1538	63	267	2	332	48	988	0	1036	3292
17:00	24	68	0	92	21	410	0	431	19	48	0	67	10	260	0	270	860
17:15	36	68	0	104	18	426	0	444	9	60	0	69	17	240	0	257	874
17:30	38	87	0	125	15	439	0	454	25	67	0	92	7	271	0	278	949
17:45	27	71	0	98	18	448	0	466	16	60	1	77	9	250	0	259	900
Total	125	294	0	419	72	1723	0	1795	69	235	1	305	43	1021	0	1064	3583
Grand Total	215	586	4	805	122	3211	0	3333	132	502	3	637	91	2009	0	2100	6875
Apprch %	26.7	72.8	0.5		3.7	96.3	0		20.7	78.8	0.5		4.3	95.7	0		
Total %	3.1	8.5	0.1	11.7	1.8	46.7	0	48.5	1.9	7.3	0	9.3	1.3	29.2	0	30.5	

Peak Hour Analysis From 16:00 to 17:45 - Peak 1 of 1
Peak Hour for Entire Intersection Begins at 17:00

17:00	24	68	0	92	21	410	0	431	19	48	0	67	10	260	0	270	860
17:15	36	68	0	104	18	426	0	444	9	60	0	69	17	240	0	257	874
17:30	38	87	0	125	15	439	0	454	25	67	0	92	7	271	0	278	949
17:45	27	71	0	98	18	448	0	466	16	60	1	77	9	250	0	259	900
Total Volume	125	294	0	419	72	1723	0	1795	69	235	1	305	43	1021	0	1064	3583
% App. Total	29.8	70.2	0		4	96	0		22.6	77	0.3		4	96	0		
PHF	.822	.845	.000	.838	.857	.961	.000	.963	.690	.877	.250	.829	.632	.942	.000	.957	.944

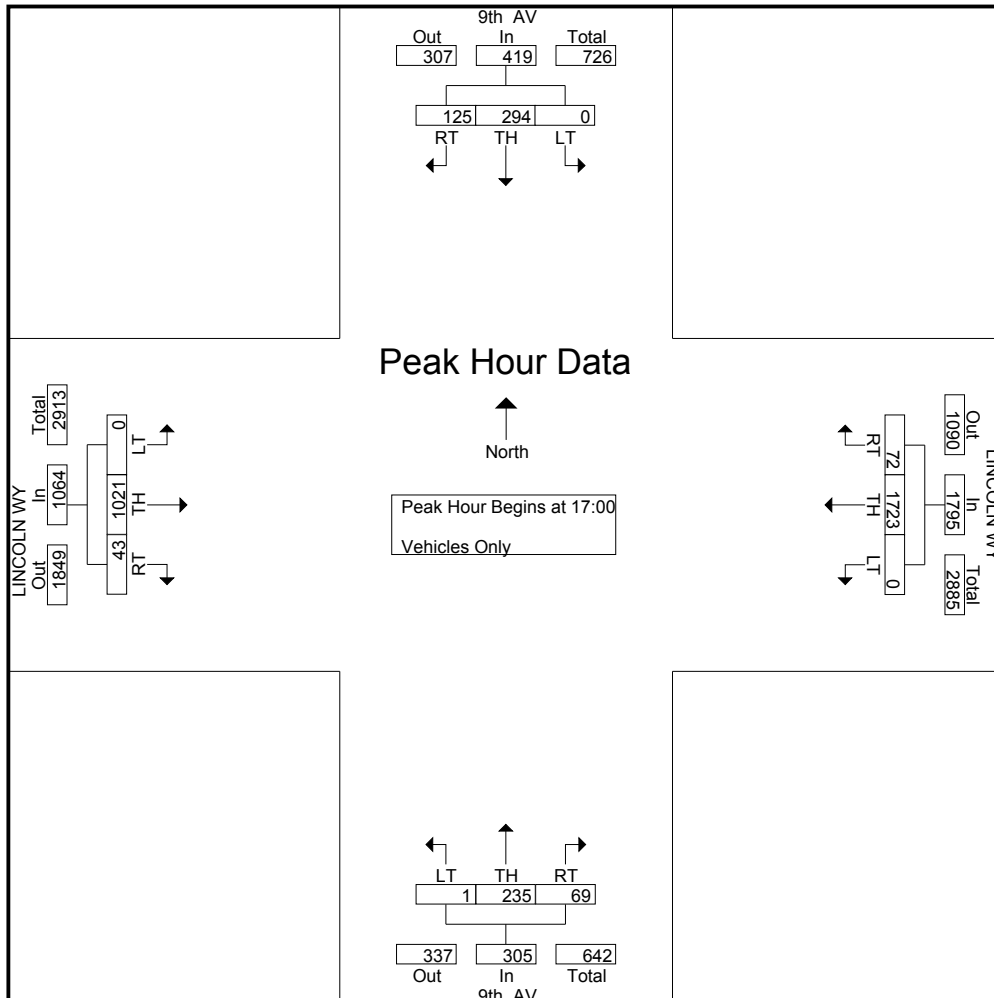



Date: 10-01-2019
 Count Period: 4:00 PM to 6:00 PM
 Peak Hour: 4:45 PM to 5:45 PM

	HV %:	PHF
EB	1.7%	0.93
WB	0.8%	0.97
NB	1.6%	0.96
SB	1.9%	0.93
NWB	-	-
TOTAL	1.3%	0.97

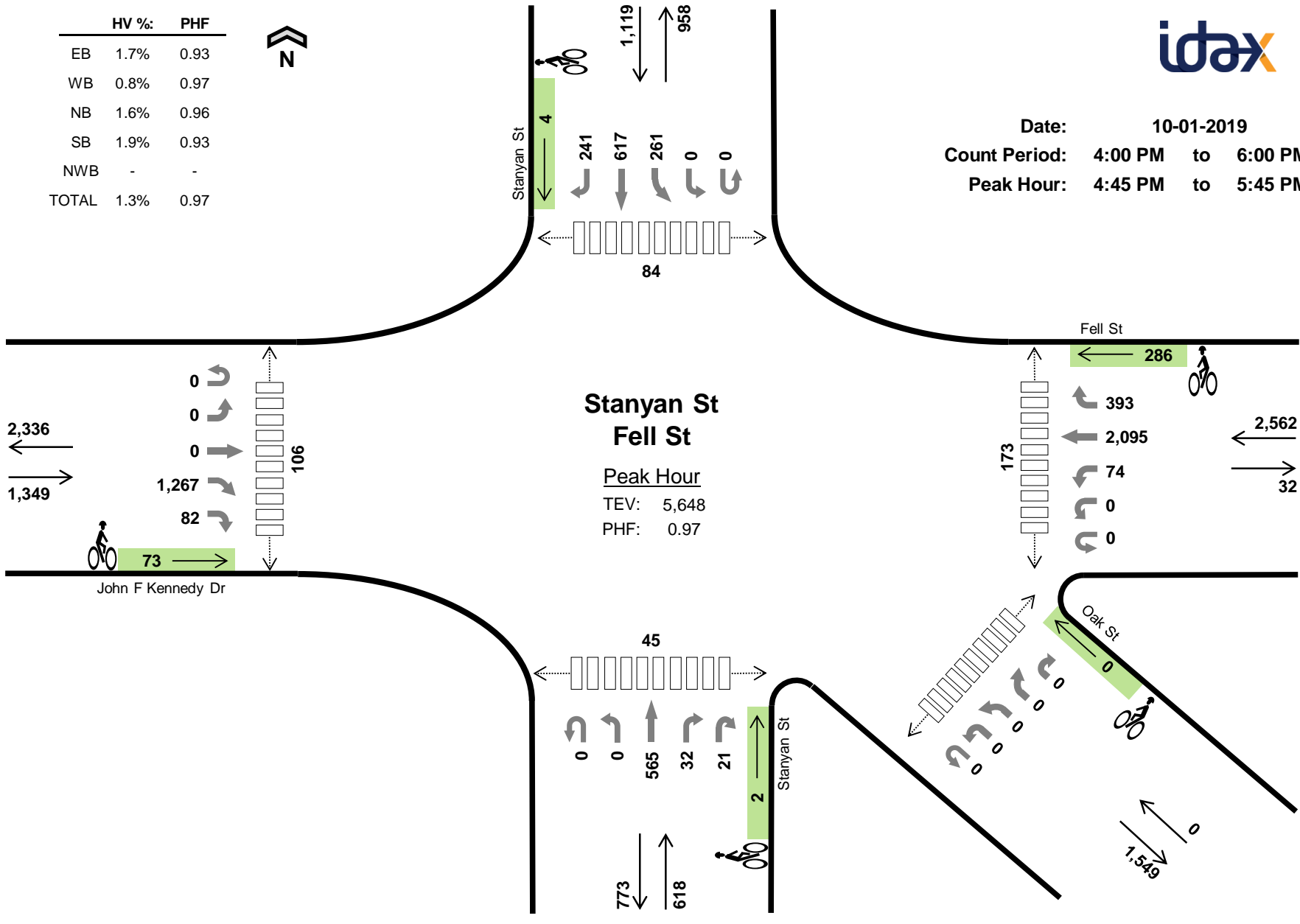

Two-Hour Count Summaries

Interval Start	John F Kennedy Dr Eastbound					Fell St Westbound					Stanyan St Northbound					Stanyan St Southbound					Oak St Northwestbound					15-min Total	Rolling One Hour
	UT	LT	TH	BR	RT	UT	HL	LT	TH	RT	UT	LT	TH	RT	HR	UT	LT	BL	TH	RT	UT	HL	BL	BR	HR		
4:00 PM	0	0	0	307	20	0	0	15	428	81	0	0	143	12	9	0	0	58	134	57	0	0	0	0	0	1,264	0
4:15 PM	0	0	0	321	12	0	0	16	428	108	0	0	145	4	6	0	0	66	120	65	0	0	0	0	0	1,291	0
4:30 PM	0	0	0	319	16	0	0	22	480	107	0	0	123	15	5	0	0	62	139	65	0	0	0	0	0	1,353	0
4:45 PM	0	0	0	318	23	0	0	23	496	109	0	0	131	4	8	0	0	66	143	52	0	0	0	0	0	1,373	5,281
5:00 PM	0	0	0	302	18	0	0	14	515	103	0	0	145	10	6	0	0	69	166	66	0	0	0	0	0	1,414	5,431
5:15 PM	0	0	0	341	22	0	0	22	540	96	0	0	141	13	3	0	0	63	148	63	0	0	0	0	0	1,452	5,592
5:30 PM	0	0	0	306	19	0	0	15	544	85	0	0	148	5	4	0	0	63	160	60	0	0	0	0	0	1,409	5,648
5:45 PM	0	0	0	306	24	0	0	21	468	84	0	1	157	7	5	0	0	67	160	53	0	0	0	0	0	1,353	5,628
Count Total	0	0	0	2,520	154	0	0	148	3,899	773	0	1	1,133	70	46	0	0	514	1,170	481	0	0	0	0	0	10,909	0
Peak Hour	All	0	0	0	1,267	82	0	0	74	2,095	393	0	0	565	32	21	0	0	261	617	241	0	0	0	0	5,648	0
	HV	0	0	0	20	3	0	0	5	13	3	0	0	10	0	0	0	0	6	11	4	0	0	0	0	75	0
	HV%	-	-	-	2%	4%	-	-	7%	1%	1%	-	-	2%	0%	0%	-	-	2%	2%	2%	-	-	-	-	-	1%

Note: Two-hour count summary volumes include heavy vehicles but exclude bicycles in overall count.

Interval Start	Heavy Vehicle Totals						Bicycles						Pedestrians (Crossing Leg)					
	EB	WB	NB	SB	NWB	Total	EB	WB	NB	SB	NWB	Total	East	West	North	South	Southeast	Total
4:00 PM	6	6	5	5	0	22	21	33	0	1	0	55	40	13	30	7	41	131
4:15 PM	2	4	7	8	0	21	15	16	0	0	0	31	42	17	16	12	21	108
4:30 PM	6	5	3	7	0	21	14	26	0	0	0	40	69	25	42	15	41	192
4:45 PM	7	9	2	6	0	24	25	34	1	0	0	60	36	11	10	12	39	108
5:00 PM	3	5	2	4	0	14	19	66	0	1	0	86	32	23	27	12	35	129
5:15 PM	6	2	1	6	0	15	17	83	1	1	0	102	48	42	21	16	42	169
5:30 PM	7	5	5	5	0	22	12	103	0	2	0	117	57	30	26	5	39	157
5:45 PM	6	7	3	5	0	21	22	65	0	0	0	87	63	40	35	21	46	205
Count Total	43	43	28	46	0	160	145	426	2	5	0	578	387	201	207	100	304	1,199
Peak Hr	23	21	10	21	0	75	73	286	2	4	0	365	173	106	84	45	155	563

Two-Hour Count Summaries - Heavy Vehicles

Interval Start	John F Kennedy Dr Eastbound					Fell St Westbound					Stanyan St Northbound					Stanyan St Southbound					Oak St Northwestbound					15-min Total	Rolling One Hour
	UT	LT	TH	BR	RT	UT	HL	LT	TH	RT	UT	LT	TH	RT	HR	UT	LT	BL	TH	RT	UT	HL	BL	BR	HR		
4:00 PM	0	0	0	4	2	0	0	0	6	0	0	0	4	0	1	0	0	1	4	0	0	0	0	0	0	22	0
4:15 PM	0	0	0	2	0	0	0	1	1	2	0	0	6	0	1	0	0	3	4	1	0	0	0	0	0	21	0
4:30 PM	0	0	0	6	0	0	0	0	5	0	0	0	2	0	1	0	0	1	5	1	0	0	0	0	0	21	0
4:45 PM	0	0	0	6	1	0	0	2	5	2	0	0	2	0	0	0	0	2	3	1	0	0	0	0	24	88	
5:00 PM	0	0	0	3	0	0	0	1	4	0	0	0	2	0	0	0	0	1	2	1	0	0	0	0	14	80	
5:15 PM	0	0	0	6	0	0	0	0	2	0	0	0	1	0	0	0	0	2	4	0	0	0	0	0	15	74	
5:30 PM	0	0	0	5	2	0	0	2	2	1	0	0	5	0	0	0	0	1	2	2	0	0	0	0	22	75	
5:45 PM	0	0	0	5	1	0	0	3	3	1	0	0	3	0	0	0	0	0	5	0	0	0	0	0	21	72	
Count Total	0	0	0	37	6	0	0	9	28	6	0	0	25	0	3	0	0	11	29	6	0	0	0	0	160	0	
Peak Hour	0	0	0	20	3	0	0	5	13	3	0	0	10	0	0	0	0	6	11	4	0	0	0	0	75	0	

Two-Hour Count Summaries - Bikes

Interval Start	John F Kennedy Dr Eastbound					Fell St Westbound					Stanyan St Northbound					Stanyan St Southbound					Oak St Northwestbound					15-min Total	Rolling One Hour
	UT	LT	TH	BR	RT	UT	HL	LT	TH	RT	UT	LT	TH	RT	HR	UT	LT	BL	TH	RT	UT	HL	BL	BR	HR		
4:00 PM	0	0	0	21	0	0	0	1	32	0	0	0	0	0	0	0	0	0	1	0	0	0	0	0	0	55	0
4:15 PM	0	0	0	15	0	0	0	0	16	0	0	0	0	0	0	0	0	0	0	0	0	0	0	0	0	31	0
4:30 PM	0	0	0	14	0	0	0	2	24	0	0	0	0	0	0	0	0	0	0	0	0	0	0	0	0	40	0
4:45 PM	0	0	0	25	0	0	0	2	32	0	0	0	0	0	1	0	0	0	0	0	0	0	0	0	0	60	186
5:00 PM	0	0	0	19	0	0	0	1	65	0	0	0	0	0	0	0	0	0	1	0	0	0	0	0	0	86	217
5:15 PM	0	0	0	17	0	0	0	2	81	0	0	0	1	0	0	0	0	0	1	0	0	0	0	0	0	102	288
5:30 PM	0	0	0	11	1	0	0	1	102	0	0	0	0	0	0	0	0	0	2	0	0	0	0	0	0	117	365
5:45 PM	0	0	0	20	2	0	0	5	60	0	0	0	0	0	0	0	0	0	0	0	0	0	0	0	0	87	392
Count Total	0	0	0	142	3	0	0	14	412	0	0	0	1	0	1	0	0	0	5	0	0	0	0	0	0	578	0
Peak Hour	0	0	0	72	1	0	0	6	280	0	0	0	1	0	1	0	0	0	4	0	0	0	0	0	0	365	0

B.A.Y.M.E.T.R.I.C.S.

INTERSECTION TURNING MOVEMENT SUMMARY

PROJECT:	SAN FRANCISCO TRAFFIC COUNTS	SURVEY DATE:	11/20/2014	DAY:	THURSDAY
N-S APPROACH:	STANYAN AVENUE	SURVEY TIME:	4:00 PM	TO	6:00 PM
E-W APPROACH:	FULTON STREET	JURISDICTION:	SAN FRANCISCO	FILE:	3411141-1AM

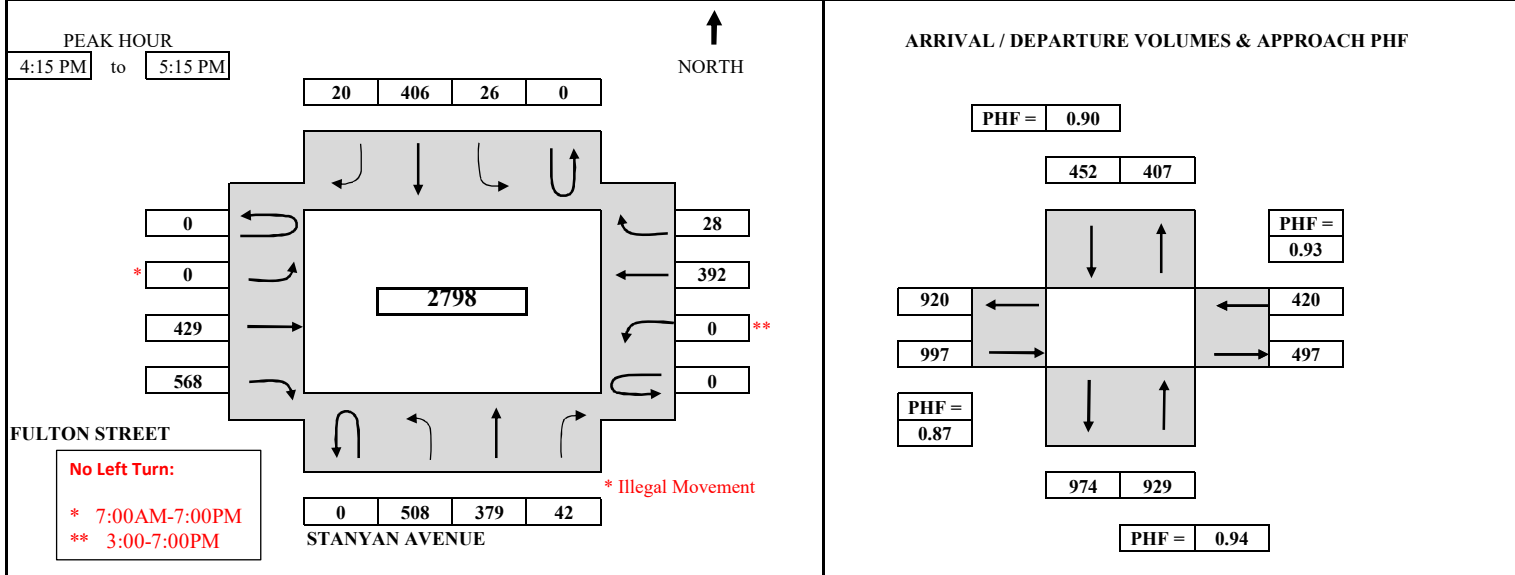

TIME PERIOD	NORTHBOUND				SOUTHBOUND				EASTBOUND				WESTBOUND				TOTAL		
	From	To	U-TURN	LEFT	THRU	RIGHT	U-TURN	LEFT	THRU	RIGHT	U-TURN	LEFT*	THRU	RIGHT	U-TURN	LEFT**		THRU	RIGHT
SURVEY DATA																			
4:00 PM	to	4:15 PM	125	103	10	5	115	3	97	133	104	10	705						
4:15 PM	to	4:30 PM	244	203	20	11	207	7	198	268	187	17	1362						
4:30 PM	to	4:45 PM	367	294	27	21	302	13	308	404	294	23	2053						
4:45 PM	to	5:00 PM	497	401	36	27	403	19	409	533	399	31	2755						
5:00 PM	to	5:15 PM	633	482	52	31	521	23	526	701	496	38	3503						
5:15 PM	to	5:30 PM	744	577	58	36	641	27	613	821	587	43	4147						
5:30 PM	to	5:45 PM	857	682	63	43	738	31	708	955	676	48	4801						
5:45 PM	to	6:00 PM	968	786	74	48	847	36	814	1126	771	52	5522						

TOTAL BY PERIOD																			
TIME PERIOD	U-TURN	LEFT	THRU	RIGHT	U-TURN	LEFT	THRU	RIGHT	U-TURN	LEFT*	THRU	RIGHT	U-TURN	LEFT**	THRU	RIGHT	TOTAL		
4:00 PM to 4:15 PM	0	125	103	10	0	5	115	3	0	0	97	133	0	0	104	10	705		
4:15 PM to 4:30 PM	0	119	100	10	0	6	92	4	0	0	101	135	0	0	83	7	657		
4:30 PM to 4:45 PM	0	123	91	7	0	10	95	6	0	0	110	136	0	0	107	6	691		
4:45 PM to 5:00 PM	0	130	107	9	0	6	101	6	0	0	101	129	0	0	105	8	702		
5:00 PM to 5:15 PM	0	136	81	16	0	4	118	4	0	0	117	168	0	0	97	7	748		
5:15 PM to 5:30 PM	0	111	95	6	0	5	120	4	0	0	87	120	0	0	91	5	644		
5:30 PM to 5:45 PM	0	113	105	5	0	7	97	4	0	0	95	134	0	0	89	5	654		
5:45 PM to 6:00 PM	0	111	104	11	0	5	109	5	0	0	106	171	0	0	95	4	721		

HOURLY TOTALS																			
TIME PERIOD	U-TURN	LEFT	THRU	RIGHT	U-TURN	LEFT	THRU	RIGHT	U-TURN	LEFT*	THRU	RIGHT	U-TURN	LEFT**	THRU	RIGHT	TOTAL		
4:00 PM to 5:00 PM	0	497	401	36	0	27	403	19	0	0	409	533	0	0	399	31	2755		
4:15 PM to 5:15 PM	0	508	379	42	0	26	406	20	0	0	429	568	0	0	392	28	2798		
4:30 PM to 5:30 PM	0	500	374	38	0	25	434	20	0	0	415	553	0	0	400	26	2785		
4:45 PM to 5:45 PM	0	490	388	36	0	22	436	18	0	0	400	551	0	0	382	25	2748		
5:00 PM to 6:00 PM	0	471	385	38	0	21	444	17	0	0	405	593	0	0	372	21	2767		

PEAK HOUR SUMMARY																			
TIME PERIOD	NBU	NBL	NBT	NBR	SBU	SBL	SBT	SBR	EBU	EBL	EBT	EBR	WBU	WBL	WBT	WBR	TOTAL		
4:15 PM to 5:15 PM	0	508	379	42	0	26	406	20	0	0	429	568	0	0	392	28	2798		
PHF BY MOVEMENT	0.00	0.93	0.89	0.66	0.00	0.65	0.86	0.83	0.00	0.00	0.92	0.85	0.00	0.00	0.92	0.88	OVERALL		
PHF BY APPROACH	0.94				0.90				0.87				0.93				0.94		

TEL: (510) 232 - 1271

FAX: (510) 232 - 1272

Location: Kezar Dr from Lincoln Wy to Oak St
 ID Number: 319
 Jurisdiction: SF
 County: SF
 Start Date: 6/30/2015
 End Date: 7/1/2015
 Days of Week: Tuesday - Wednesday



48-Hour Volume Report

	EB	Westbound		Hourly Totals			
	Lane 1	Lane 1	Lane 2	EB	WB	Combined	
6/30/2015	157	88	108	157	196	353	
1:00 AM	100	41	69	100	110	210	
2:00 AM	88	39	32	88	71	159	
3:00 AM	85	17	28	85	45	130	
4:00 AM	126	70	78	126	148	274	
5:00 AM	344	129	143	344	272	616	
6:00 AM	894	256	240	894	496	1390	
7:00 AM	1543	379	382	1543	761	2304	
8:00 AM	1690	433	421	1690	854	2544	
9:00 AM	1517	465	430	1517	895	2412	
10:00 AM	1273	490	479	1273	969	2242	
11:00 AM	1113	573	581	1113	1154	2267	
12:00 PM	1130	572	549	1130	1121	2251	
1:00 PM	1125	556	565	1125	1121	2246	
2:00 PM	1189	701	638	1189	1339	2528	
3:00 PM	1157	771	746	1157	1517	2674	
4:00 PM	1116	758	744	1116	1502	2618	
5:00 PM	1196	773	814	1196	1587	2783	<---Peak Hour Volume
6:00 PM	985	668	663	985	1331	2316	
7:00 PM	885	526	502	885	1028	1913	
8:00 PM	759	425	476	759	901	1660	
9:00 PM	707	405	432	707	837	1544	
10:00 PM	563	253	304	563	557	1120	
11:00 PM	343	180	199	343	379	722	
7/1/2015	184	75	105	184	180	364	
1:00 AM	114	50	71	114	121	235	
2:00 AM	75	27	39	75	66	141	
3:00 AM	75	32	37	75	69	144	
4:00 AM	146	80	82	146	162	308	
5:00 AM	362	142	139	362	281	643	
6:00 AM	895	271	235	895	506	1401	
7:00 AM	1479	394	343	1479	737	2216	
8:00 AM	1679	466	411	1679	877	2556	
9:00 AM	1533	440	472	1533	912	2445	
10:00 AM	1224	513	505	1224	1018	2242	
11:00 AM	1177	557	532	1177	1089	2266	
12:00 PM	1141	567	541	1141	1108	2249	
1:00 PM	1121	619	575	1121	1194	2315	
2:00 PM	1202	667	649	1202	1316	2518	
3:00 PM	1187	765	701	1187	1466	2653	
4:00 PM	1118	814	818	1118	1632	2750	
5:00 PM	1188	762	761	1188	1523	2711	
6:00 PM	1009	645	655	1009	1300	2309	
7:00 PM	929	498	493	929	991	1920	
8:00 PM	747	444	484	747	928	1675	
9:00 PM	696	406	436	696	842	1538	
10:00 PM	555	294	327	555	621	1176	
11:00 PM	348	152	216	348	368	716	
Total	40269	19248	19250	40269	38498	78767	

JFK Bike-Ped Counts

Through October 14th before rains, reflecting period when vehicle counts were collected
4-5 PM

Mid-Week	Bikes/Scooters		Peds	
	East	West	East	West
Average	166	13	282	198

5-6pm,							Data points
Mid-Week	Bikes/Scooters		Peds		Ave		
Average	East	West	East	West	321	138	
	227	13	387	254			

Existing Plus Project Geometry

↔ Conflicting peds

↔ Conflicting bikes

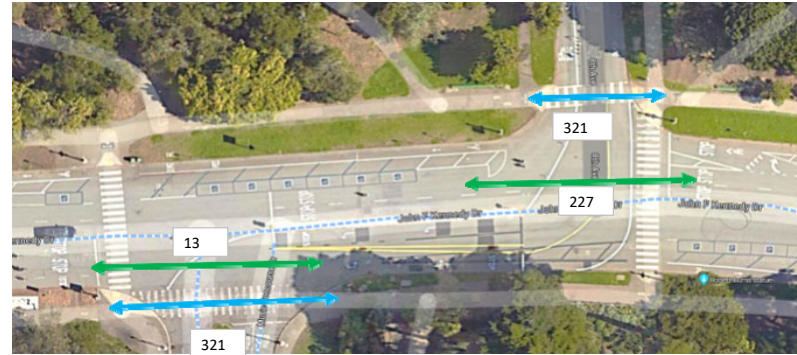

Period August 7, 2021 →
December 19, 2021
PM Peak hours

Time	JFK Drive @ Tea Garden 15' SOUTH eastbound BIKES/SCOOTERS	JFK Drive @ Tea Garden 15' SOUTH westbound BIKES/SCOOTERS	JFK Drive @ Tea Garden north 50' Westbound JFK Drive @ Tea Garden north 50' Pedestrian IN	JFK Drive @ Tea Garden north 50' Eastbound JFK Drive @ Tea Garden north 50' Pedestrian OUT	JFK Drive @ Tea Garden ALL Eastbound	JFK Drive @ Tea Garden ALL WESTBOUND
07-08-2021 16:00:00	198	34	401	260	458	435
07-08-2021 17:00:00	185	13	235	213	398	248
08-08-2021 16:00:00	233	31	369	250	483	400
08-08-2021 17:00:00	156	7	262	201	357	269
09-08-2021 16:00:00	167	10	266	181	348	276
09-08-2021 17:00:00	197	11	356	215	412	367
10-08-2021 16:00:00	205	14	310	244	449	324
10-08-2021 17:00:00	250	20	470	286	536	490
11-08-2021 16:00:00	149	10	252	187	336	262
11-08-2021 17:00:00	197	8	301	217	414	309
12-08-2021 16:00:00	131	12	262	173	304	274
12-08-2021 17:00:00	168	10	312	184	352	322
13-08-2021 16:00:00	185	5	247	216	401	252
13-08-2021 17:00:00	170	5	256	206	376	261
14-08-2021 16:00:00	207	18	318	216	423	336
14-08-2021 17:00:00	173	14	224	198	371	238
15-08-2021 16:00:00	258	33	360	317	575	393
15-08-2021 17:00:00	219	14	235	214	433	249
16-08-2021 16:00:00	214	15	340	255	469	355
16-08-2021 17:00:00	275	17	448	312	587	465
17-08-2021 16:00:00	158	7	285	180	338	292
17-08-2021 17:00:00	222	21	438	247	469	459
18-08-2021 16:00:00	165	12	255	201	366	267
18-08-2021 17:00:00	218	38	375	240	458	413
19-08-2021 16:00:00	154	42	278	183	337	320
19-08-2021 17:00:00	173	16	302	236	409	318
20-08-2021 16:00:00	169	10	193	184	353	203
20-08-2021 17:00:00	156	6	243	177	333	249
21-08-2021 16:00:00	219	23	297	229	448	320
21-08-2021 17:00:00	124	7	246	173	297	253
22-08-2021 16:00:00	386	35	530	444	830	565
22-08-2021 17:00:00	278	20	312	337	615	332
23-08-2021 16:00:00	131	7	234	148	279	241
23-08-2021 17:00:00	201	6	372	214	415	378
24-08-2021 16:00:00	150	6	239	158	308	245
24-08-2021 17:00:00	208	5	354	223	431	359
25-08-2021 16:00:00	183	16	333	223	406	349
25-08-2021 17:00:00	278	27	441	315	593	468
26-08-2021 16:00:00	168	19	322	223	391	341
26-08-2021 17:00:00	236	22	435	323	559	457
27-08-2021 16:00:00	166	8	313	234	400	321
27-08-2021 17:00:00	221	16	357	269	490	373
28-08-2021 16:00:00	329	25	356	396	725	381
28-08-2021 17:00:00	284	30	372	363	647	402
29-08-2021 16:00:00	283	17	388	325	608	405
29-08-2021 17:00:00	169	13	258	205	374	271
30-08-2021 16:00:00	171	25	283	199	370	308
30-08-2021 17:00:00	178	10	353	235	413	363
31-08-2021 16:00:00	161	17	266	196	357	283
31-08-2021 17:00:00	233	8	378	262	495	386
01-09-2021 16:00:00	159	13	253	196	355	266
01-09-2021 17:00:00	171	10	311	198	369	321
02-09-2021 16:00:00	168	7	256	204	372	263
02-09-2021 17:00:00	200	10	362	225	425	372
03-09-2021 16:00:00	181	8	265	219	400	273
03-09-2021 17:00:00	156	13	246	179	335	259
04-09-2021 16:00:00	231	29	357	283	514	386
04-09-2021 17:00:00	176	15	281	228	404	296
05-09-2021 16:00:00	347	32	421	406	753	453
05-09-2021 17:00:00	249	22	288	281	530	310
06-09-2021 16:00:00	372	53	482	453	825	535
06-09-2021 17:00:00	333	26	361	384	717	387
07-09-2021 16:00:00	137	9	250	171	308	259
07-09-2021 17:00:00	217	9	423	249	466	432
08-09-2021 16:00:00	201	19	326	252	453	345
08-09-2021 17:00:00	264	8	451	289	553	459
09-09-2021 16:00:00	133	12	214	166	299	226
09-09-2021 17:00:00	172	5	283	199	371	288
10-09-2021 16:00:00	162	16	264	197	359	280
10-09-2021 17:00:00	177	8	264	195	372	272

11-09-2021 16:00:00	243	21	317	249	492	338
11-09-2021 17:00:00	190	10	236	221	411	246
12-09-2021 16:00:00	299	28	464	347	646	492
12-09-2021 17:00:00	239	11	266	250	489	277
13-09-2021 16:00:00	178	13	337	224	402	350
13-09-2021 17:00:00	271	23	460	314	585	483
14-09-2021 16:00:00	149	8	255	204	353	263
14-09-2021 17:00:00	223	9	349	248	471	358
15-09-2021 16:00:00	137	3	227	146	283	230
15-09-2021 17:00:00	190	9	348	209	399	357
16-09-2021 16:00:00	135	9	245	172	307	254
16-09-2021 17:00:00	198	8	316	206	404	324
17-09-2021 16:00:00	168	8	269	197	365	277
17-09-2021 17:00:00	184	4	306	213	397	310
18-09-2021 16:00:00	210	16	282	262	472	298
18-09-2021 17:00:00	137	13	216	166	303	229
19-09-2021 16:00:00	273	14	348	294	567	362
19-09-2021 17:00:00	186	16	327	207	393	343
20-09-2021 16:00:00	150	18	350	235	385	368
20-09-2021 17:00:00	233	17	508	302	535	525
21-09-2021 16:00:00	143	15	338	214	357	353
21-09-2021 17:00:00	260	13	535	296	556	548
22-09-2021 16:00:00	133	14	289	171	304	303
22-09-2021 17:00:00	223	14	343	270	493	357
23-09-2021 16:00:00	173	15	317	202	375	332
23-09-2021 17:00:00	237	18	395	255	492	413
24-09-2021 16:00:00	143	8	202	181	324	210
24-09-2021 17:00:00	165	14	279	173	338	293
25-09-2021 16:00:00	229	8	295	254	483	303
25-09-2021 17:00:00	142	10	183	177	319	193
26-09-2021 16:00:00	256	12	321	255	511	333
26-09-2021 17:00:00	194	10	190	199	393	200
27-09-2021 16:00:00	139	6	195	154	293	201
27-09-2021 17:00:00	183	11	279	181	364	290
28-09-2021 16:00:00	217	15	378	254	471	393
28-09-2021 17:00:00	316	15	526	352	668	541
29-09-2021 16:00:00	241	13	357	278	519	370
29-09-2021 17:00:00	284	21	418	313	597	439
30-09-2021 16:00:00	173	20	360	226	399	380
30-09-2021 17:00:00	289	15	453	320	609	468
01-10-2021 16:00:00	203	13	317	242	445	330
01-10-2021 17:00:00	247	13	386	286	533	399
02-10-2021 16:00:00	248	20	374	332	580	394
02-10-2021 17:00:00	215	28	311	282	497	339
03-10-2021 16:00:00	298	16	389	372	670	405
03-10-2021 17:00:00	265	25	301	314	579	326
04-10-2021 16:00:00	181	10	303	198	379	313
04-10-2021 17:00:00	246	12	441	246	492	453
05-10-2021 16:00:00	147	4	246	160	307	250
05-10-2021 17:00:00	242	11	397	255	497	408
06-10-2021 16:00:00	184	8	273	200	384	281
06-10-2021 17:00:00	203	13	342	224	427	355
07-10-2021 16:00:00	146	11	232	155	301	243
07-10-2021 17:00:00	175	8	337	196	371	345
08-10-2021 16:00:00	186	4	229	209	395	233
08-10-2021 17:00:00	196	14	251	208	404	265
09-10-2021 16:00:00	271	15	341	272	543	356
09-10-2021 17:00:00	237	17	261	249	486	278
10-10-2021 16:00:00	313	27	306	325	638	333
10-10-2021 17:00:00	235	10	289	230	465	299
11-10-2021 16:00:00	178	18	267	177	355	285
11-10-2021 17:00:00	217	11	355	241	458	366
12-10-2021 16:00:00	185	11	274	201	386	285
12-10-2021 17:00:00	267	14	411	254	521	425
13-10-2021 16:00:00	162	11	252	176	338	263
13-10-2021 17:00:00	220	3	358	232	452	361
14-10-2021 16:00:00	219	16	321	225	444	337
14-10-2021 17:00:00	267	11	457	287	554	468
15-10-2021 16:00:00	227	28	351	242	469	379
15-10-2021 17:00:00	277	11	400	267	544	411
16-10-2021 16:00:00	364	31	408	375	739	439
16-10-2021 17:00:00	336	48	347	340	676	395
17-10-2021 16:00:00	188	13	244	215	403	257
17-10-2021 17:00:00	132	7	124	129	261	131
18-10-2021 16:00:00	189	16	253	186	375	269
18-10-2021 17:00:00	276	11	455	258	534	466
19-10-2021 16:00:00	151	5	293	157	308	298
19-10-2021 17:00:00	254	11	402	249	503	413
20-10-2021 16:00:00	81	10	130	93	174	140
20-10-2021 17:00:00	83	2	141	72	155	143

21-10-2021 16:00:00	100	11	185	104	204	196
21-10-2021 17:00:00	179	10	301	166	345	311
22-10-2021 16:00:00	190	9	249	198	388	258
22-10-2021 17:00:00	201	17	287	216	417	304
23-10-2021 16:00:00	117	13	160	134	251	173
23-10-2021 17:00:00	95	7	119	122	217	126
24-10-2021 16:00:00	16	1	27	6	22	28
24-10-2021 17:00:00	15	4	17	8	23	21
25-10-2021 16:00:00	160	7	301	167	327	308
25-10-2021 17:00:00	243	22	480	264	507	502
26-10-2021 16:00:00	152	10	247	177	329	257
26-10-2021 17:00:00	243	11	391	259	502	402
27-10-2021 16:00:00	192	21	323	199	391	344
27-10-2021 17:00:00	300	14	493	280	580	507
28-10-2021 16:00:00	197	12	303	201	398	315
28-10-2021 17:00:00	261	10	429	258	519	439
29-10-2021 16:00:00	156	17	460	173	329	477
29-10-2021 17:00:00	140	10	343	141	281	353
30-10-2021 16:00:00	107	15	314	127	234	329
30-10-2021 17:00:00	96	13	209	119	215	222
31-10-2021 16:00:00	169	20	316	191	360	336
31-10-2021 17:00:00	133	8	204	145	278	212
01-11-2021 16:00:00	78	8	124	89	167	132
01-11-2021 17:00:00	100	11	178	111	211	189
02-11-2021 16:00:00	214	9	352	223	437	361
02-11-2021 17:00:00	305	16	530	296	601	546
03-11-2021 16:00:00	205	18	359	204	409	377
03-11-2021 17:00:00	309	14	492	295	604	506
04-11-2021 16:00:00	179	12	273	185	364	285
04-11-2021 17:00:00	248	20	430	267	515	450
05-11-2021 16:00:00	191	15	241	184	375	256
05-11-2021 17:00:00	188	17	298	203	391	315
06-11-2021 16:00:00	196	12	255	210	406	267
06-11-2021 17:00:00	198	12	219	203	401	231
07-11-2021 16:00:00	340	10	350	360	700	360
07-11-2021 17:00:00	170	3	128	191	361	131
08-11-2021 16:00:00	118	14	185	144	262	199
08-11-2021 17:00:00	78	7	117	90	168	124
09-11-2021 16:00:00	143	11	270	148	291	281
09-11-2021 17:00:00	198	4	237	222	420	241
10-11-2021 16:00:00	290	14	392	315	605	406
10-11-2021 17:00:00	262	15	306	259	521	321
11-11-2021 16:00:00	305	12	389	315	620	401
11-11-2021 17:00:00	240	9	267	257	497	276
12-11-2021 16:00:00	315	14	407	281	596	421
12-11-2021 17:00:00	230	15	230	253	483	245
13-11-2021 16:00:00	336	13	377	334	670	390
13-11-2021 17:00:00	187	9	135	204	391	144
14-11-2021 16:00:00	316	17	322	304	620	339
14-11-2021 17:00:00	183	19	121	176	359	140
15-11-2021 16:00:00	191	9	284	183	374	293
15-11-2021 17:00:00	169	7	216	185	354	223
16-11-2021 16:00:00	264	15	363	247	511	378
16-11-2021 17:00:00	213	10	237	213	426	247
17-11-2021 16:00:00	263	15	340	255	518	355
17-11-2021 17:00:00	212	15	235	220	432	250
18-11-2021 16:00:00	149	13	230	152	301	243
18-11-2021 17:00:00	143	17	188	145	288	205
19-11-2021 16:00:00	155	10	214	153	308	224
19-11-2021 17:00:00	121	5	150	137	258	155
20-11-2021 16:00:00	306	19	307	286	592	326
20-11-2021 17:00:00	191	11	123	180	371	134
21-11-2021 16:00:00	360	12	347	320	680	359
21-11-2021 17:00:00	188	6	113	188	376	119
22-11-2021 16:00:00	230	21	350	217	447	371
22-11-2021 17:00:00	203	6	198	197	400	204
23-11-2021 16:00:00	239	13	328	224	463	341
23-11-2021 17:00:00	168	6	167	181	349	173
24-11-2021 16:00:00	256	13	253	230	486	266
24-11-2021 17:00:00	120	4	131	127	247	135
25-11-2021 16:00:00	118	14	105	104	222	119
25-11-2021 17:00:00	42	3	25	49	91	28
26-11-2021 16:00:00	249	12	230	219	468	242
26-11-2021 17:00:00	109	5	95	112	221	100
27-11-2021 16:00:00	295	22	334	254	549	356
27-11-2021 17:00:00	158	11	102	186	344	113
28-11-2021 16:00:00	336	18	367	300	636	385
28-11-2021 17:00:00	150	9	103	155	305	112
29-11-2021 16:00:00	210	6	329	176	386	335
29-11-2021 17:00:00	142	14	206	153	295	220

30-11-2021 16:00:00	260	15	367	253	513	382
30-11-2021 17:00:00	195	13	243	197	392	256
01-12-2021 16:00:00	256	12	350	233	489	362
01-12-2021 17:00:00	206	10	230	208	414	240
02-12-2021 16:00:00	220	8	262	201	421	270
02-12-2021 17:00:00	153	10	179	161	314	189
03-12-2021 16:00:00	161	9	235	166	327	244
03-12-2021 17:00:00	142	9	149	154	296	158
04-12-2021 16:00:00	230	18	269	212	442	287
04-12-2021 17:00:00	133	14	110	141	274	124
05-12-2021 16:00:00	340	27	369	290	630	396
05-12-2021 17:00:00	177	3	125	160	337	128
06-12-2021 16:00:00	141	8	218	151	292	226
06-12-2021 17:00:00	111	7	148	119	230	155
07-12-2021 16:00:00	261	11	332	229	490	343
07-12-2021 17:00:00	179	8	209	183	362	217
08-12-2021 16:00:00	89	13	169	94	183	182
08-12-2021 17:00:00	103	8	157	108	211	165
09-12-2021 16:00:00	220	11	292	211	431	303
09-12-2021 17:00:00	152	11	194	169	321	205
10-12-2021 16:00:00	232	16	300	216	448	316
10-12-2021 17:00:00	152	10	160	161	313	170
11-12-2021 16:00:00	314	23	257	293	607	280
11-12-2021 17:00:00	158	11	131	153	311	142
12-12-2021 16:00:00	35	11	55	41	76	66
12-12-2021 17:00:00	15	2	18	11	26	20
13-12-2021 16:00:00	21	4	52	27	48	56
13-12-2021 17:00:00	23	2	38	22	45	40
14-12-2021 16:00:00	190	9	243	29	219	252
14-12-2021 17:00:00	136	10	149	19	155	159
15-12-2021 16:00:00	61	7	73	4	65	80
15-12-2021 17:00:00	48	4	46	3	51	50
16-12-2021 16:00:00	176	13	262	35	211	275
16-12-2021 17:00:00	157	10	155	15	172	165
17-12-2021 16:00:00	222	13	212	41	263	225
17-12-2021 17:00:00	129	7	124	18	147	131
18-12-2021 16:00:00	183	16	190	29	212	206
18-12-2021 17:00:00	105	10	68	16	121	78
19-12-2021 16:00:00	155	13	142	20	175	155
19-12-2021 17:00:00	82	7	43	10	92	50