



SFMTA

Geary Community Advisory Committee

May 19, 2020

Order of Business

1. Call to Order
2. Virtual meeting etiquette
3. Roll call
4. Ice breaker activity
5. Approval of minutes – [January 21, 2020](#) (March 17 cancelled)
6. Public comment
7. Announcements
8. Geary Rapid – Steiner bridge demolition update with Public Works and Silicon Valley Demolition (contractor)
9. Geary Rapid – Project update
10. Geary Rapid – Implementation update
11. Geary Rapid – Outreach update
12. Geary Boulevard Improvement Project – update
13. Adjourn

2. Virtual Meeting Etiquette

- Skype for Business – download for desktop or mobile at: www.microsoft.com/en-us/microsoft-365/skype-for-business/download-app
- Key functions: mute/unmute, chat
- Please stay on mute unless called on to speak by Chair

3. Roll Call

4. Ice breaker

What is one thing you are doing to stay sane during Shelter in Place?

5. Approval of Minutes

- January 21, 2020

6. Public Comment

- See Public Comment Policy on back of agenda.
- Public comment for matters within the Geary Community Advisory Committee jurisdiction and are not on today's calendar.
- Public comment is limited to two minutes each.

7. Announcements

COVID-19 Update

- Geary Rapid Projects have all been continuing as essential work. Crews observing social distancing and safe work environment requirements
- Substantial Muni service reduction, but 38 Geary and 38R Geary Rapid continue to operate
- More information [SFMTA.com/COVID](https://www.sfmta.com/COVID)

8. Geary Rapid – Steiner bridge demolition

- Work confirmed for Memorial Day weekend, 8:00 p.m. Friday May 22 through Monday, May 25, rain or shine
- Each of the three spans will be disconnected from supports, lifted by cranes and loaded onto trailers to be delivered to disposal facilities



8. Geary Rapid – Steiner bridge demolition

- Spiral and folded ramps will be demolished in-place using hydraulic concrete processors to break up structures; debris loaded into dump trucks for transport off-site
- Outreach plan shared at prior meetings is in process of being executed, though with limited door-to-door outreach



8. Geary Rapid – Steiner bridge demolition

More information: SFMTA.com/SteinerBridge

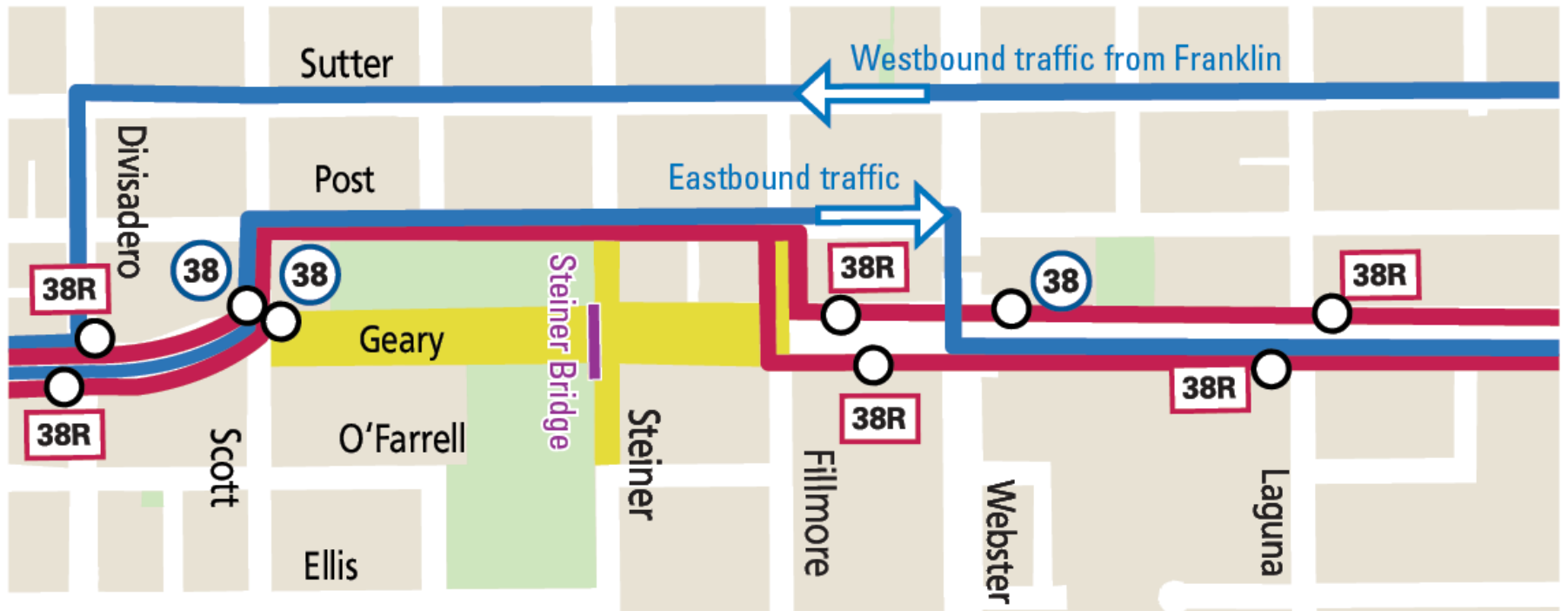

Street Closures
街道關閉/Cierre de calles/
도로 폐쇄

Vehicle Reroute
車輛繞道/Reruta del vehículo/
차량 우회

Bus Reroute
巴士繞道/Reruta de autobús/
버스 우회

38 Geary Bus Stop
38號巴士站/Parada del 38 Geary/
38번 Geary 버스 정류장

8. Geary Rapid – Steiner bridge demolition

Q&A with Mike Schwach from Silicon Valley Demolition

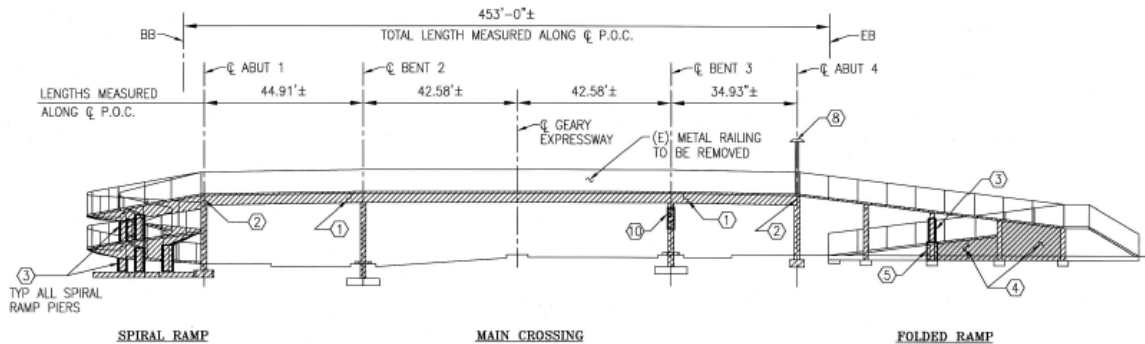

ELEVATION
SCALE: 1"=20'

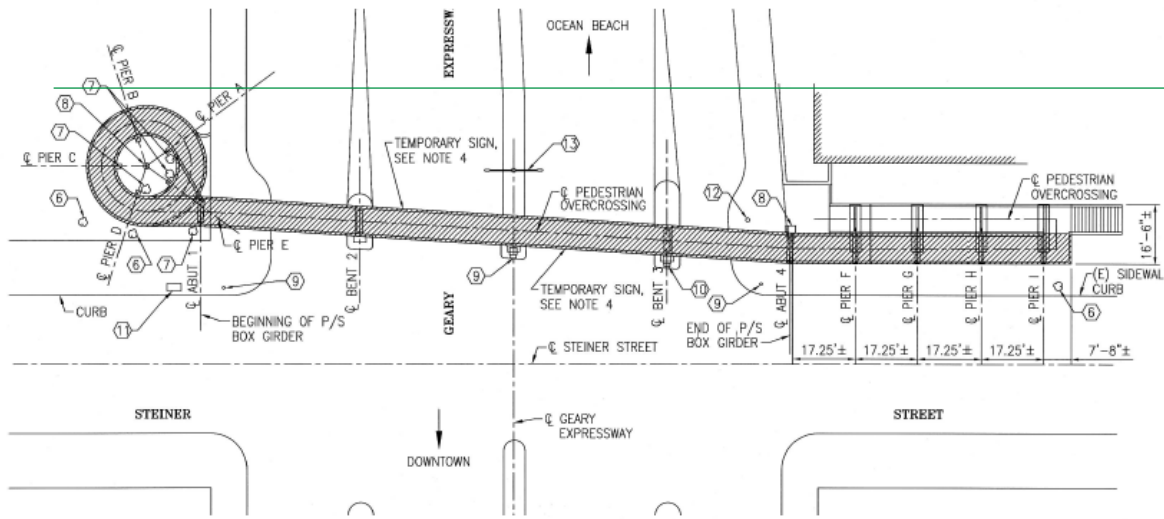

PLAN
SCALE: 1"=20'



9. Geary Rapid Project updates

Geary Rapid Project - Project Report SFMTA only		
	Design	Construction
Budget	\$ 5.0M	\$ 31.0M
Expenditures*	\$ 4.7M	\$ 6.3M
% expended	94%	20%
Budget Status	Closing out	On track
Est. Completion	Summer '19	Sept '21
Schedule Status	Complete	On track
<i>*financial data as of 5/4/2020</i>		



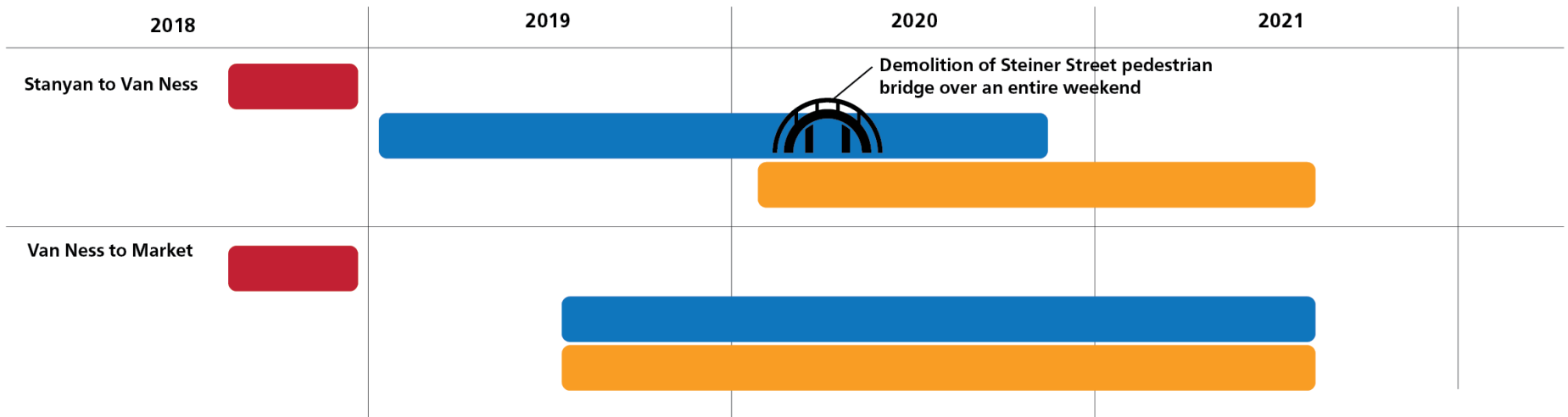

Geary Rapid Project - All Construction Contracts includes MTA, PUC Sewer and Water, DT, Paving and Curb Ramps			
Contract/Work	Estimated	Price	Status (% paid)
MTA Near-Term	\$ 1.0M	\$ 1.0M	Complete
PUC Sewer/Water	\$ 16.0M	\$ 16.2M	Underway (65%)
PW Geary East	\$ 6.2M	\$ 8.7M	Underway (32%)
PW Steiner Demo	\$ 1.0M	\$ 0.8M	Underway (0%)
PW Geary West	\$ 16.6M	\$ 16.0M	Underway (0%)
	\$ 40.8M	\$ 42.7M	Underway (34%)

10. Geary Rapid – Implementation update



Overview







Transit and safety treatments

-  Bus-only lanes
-  Pedestrian safety treatments
-  Bus stop changes
-  Roadway striping changes

Utility upgrades

-  Water main replacement on Geary (Masonic to Market)
-  Fiber-optic cable conduits (Stanyan to Gough)
-  Sewer main replacement (primarily Masonic to Van Ness)

Major transit and safety improvements

-  Bus bulbs
-  Upgraded traffic signals
-  Pedestrian bulbs
-  Roadway repaving (Masonic to Van Ness)

10. Geary Rapid – Implementation update

“Geary Blvd Water/Sewer” contract: Masonic to Van Ness

- “Segment A” work is complete (Masonic to Fillmore).
- “Segment B” is underway between Fillmore and Franklin.

“Geary East” contract: Van Ness to Market Street

- Water main work is underway between Polk and Jones streets.
Some pedestrian bulbs on O’Farrell Street have been completed



10. Geary Rapid – Implementation update

“Geary East” contract: Van Ness to Market Street

- Decommissioned cable car tracks from old O’Farrell line (discontinued 1954) found at O’Farrell/ Shannon



11. Geary Rapid – Outreach update

Construction Mitigation and Business Support

Japantown, Fillmore and Tenderloin wayfinding signs:



11. Geary Rapid – Outreach update

Construction Mitigation and Business Support

Japantown garage signage:

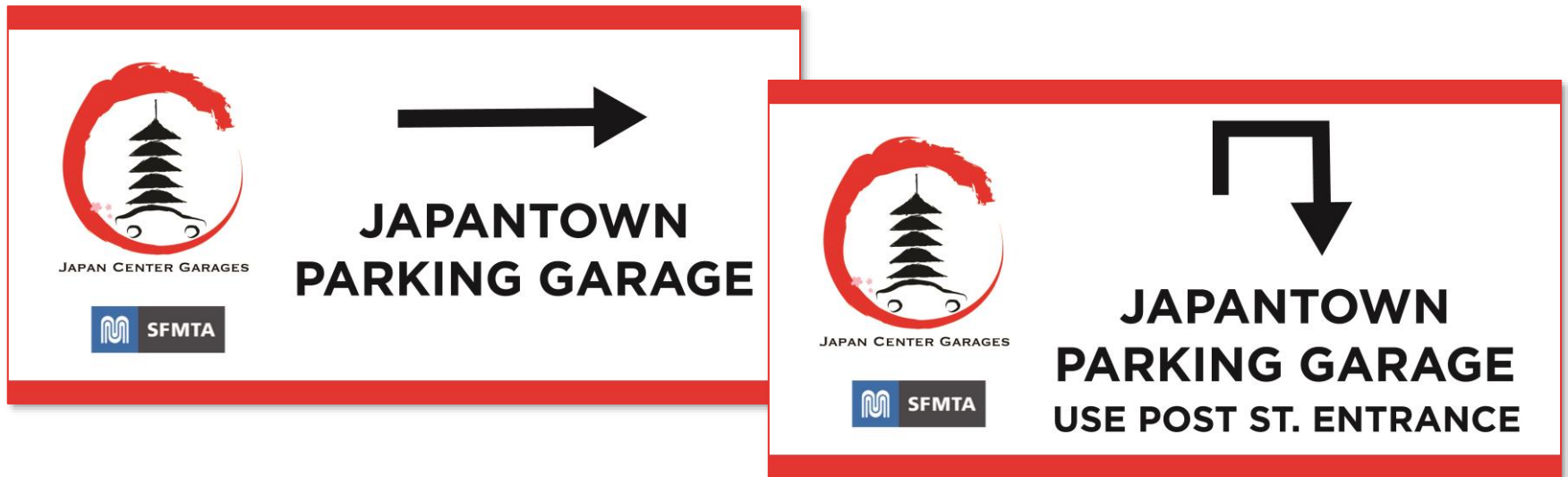

11. Geary Rapid – Outreach update

Recent Events/Meetings

- Engineering Public Hearings
 - January 24, 2020: Commonwealth Traffic Signal and Turn Restrictions – APPROVED
 - February 21, 2020: Beaumont Stop Signs – APPROVED
- Bureau of Urban Forestry tree removal hearing
 - January 27, 2020
- Japantown merchant meeting
 - February 13, 2020
- Tenderloin business support meetings with Tenderloin Community Benefit District (TLCBD) and Tenderloin Equitable Development Project (TEDP)
 - March & April



Geary Rapid Project MUNIFORWARD 

Please join us for a Japantown Merchants Meeting



Please join the SFMTA and Office of Economic and Workforce Development to learn about construction of the Geary Rapid Project and resources that are available to help support businesses.
A presentation will be followed by Q&A with project staff. Light refreshments served.

Thursday, February 13
3:00 p.m. - 5:00 p.m.
Union Bank Community Room
Japan Center East Mall

GearyRapid@SFMTA.com | SFMTA.com/Geary

11. Geary Rapid – Outreach update

Other Outreach

- Geary Rapid Project Newsletter
 - Winter 2020 issue mailed along project corridor, emailed/texted to project subscribers and posted to website
- Vision Zero outreach
 - Posters and palm cards to Japan Center Parking Garage
- Transit Lanes PSA campaign
 - Website, YouTube videos, bus cards and tails, marketing, and community outreach

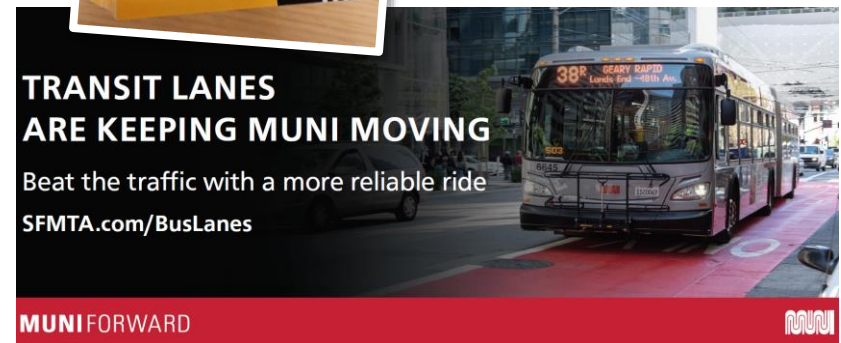
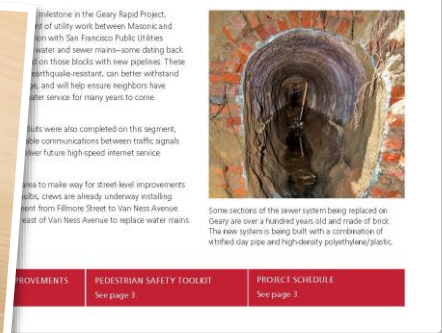

12. Geary Boulevard Improvement Project update



13. Adjourn

Thank you!

Next meeting:

- July 21, 2020, 6:00 p.m.
- 1 South Van Ness Avenue, 7th Floor,
Union Square Conference Room